



**TELEDYNE**  
**OLDHAM SIMTRONICS**  
Everywhereyoulook™

## **OPERATING MANUAL**

# **MULTIXPLO AND MULTITOX DETECTORS**



DG-TX7-X (Catalytic)

DG-TT7-K (Catharometer)

(with Magnetic interface)

# MULTIXPLO AND MULTITOX DETECTORS

OPERATING MANUAL

User manuals in other languages are available on  
Website <https://teledynegasandflamedetection.com>



Copyright © June 2024 by TELEDYNE OLDHAM SIMTRONICS S.A.S.

All rights reserved. No reproduction of all or part of this document, in any form, is permitted without the written consent of TELEDYNE OLDHAM SIMTRONICS S.A.S.

All of the information that is provided in this document is accurate to the best of our knowledge.

As a result of continuous research and development, the specifications of this product may be changed without prior notice.

TELEDYNE OLDHAM SIMTRONICS S.A.S.

Rue Orfila

Z.I. Est – CS 20417

62027 ARRAS Cedex

## Limitation of Liability

The Company TELEDYNE OLDHAM SIMTRONICS S.A.S., hereinafter referred to as "TELEDYNE OLDHAM SIMTRONICS" throughout this document, shall not be held responsible for any damage to the equipment or for any physical injury or death resulting in whole or in part from the inappropriate use or installation of the equipment, non-compliance with any and all instructions, warnings, standards and/or regulations in force.

No business, person or legal entity may assume responsibility on behalf of TELEDYNE OLDHAM SIMTRONICS, even though they may be involved in the sale of TELEDYNE OLDHAM SIMTRONICS products.

TELEDYNE OLDHAM SIMTRONICS shall not be responsible for any direct or indirect damage, or any direct or indirect consequence, resulting from the sale and use of any of its products **UNLESS SUCH PRODUCTS HAVE BEEN SELECTED BY TELEDYNE OLDHAM SIMTRONICS ACCORDING TO THE APPLICATION.**

## Ownership clauses

The drawings, specifications, and information herein contain confidential information that is the property of TELEDYNE OLDHAM SIMTRONICS.

This information shall not, either in whole or in part, by physical, electronic, or any other means whatsoever, be reproduced, copied, divulged, translated, or used as the basis for the manufacture or sale of TELEDYNE OLDHAM SIMTRONICS equipment, or for any other reason **without the prior consent of TELEDYNE OLDHAM SIMTRONICS.**

## Warning

This is not a contractual document. In the best interest of its customers and with the aim of improving performance, TELEDYNE OLDHAM SIMTRONICS reserves the right to alter the technical features of its equipment without prior notice.

**READ THESE INSTRUCTIONS CAREFULLY BEFORE THE FIRST USAGE:** these instructions should be read by all persons who have or will have responsibility for the use, maintenance, or repair of the instrument.

This instrument shall only be deemed to be in conformance with the published performance if used, maintained, and repaired in accordance with the instructions of TELEDYNE OLDHAM SIMTRONICS by TELEDYNE OLDHAM SIMTRONICS personnel or by personnel authorized by TELEDYNE OLDHAM SIMTRONICS.

## Important Information

The modification of the material and the use of parts of an unspecified origin shall entail the cancellation of any form of warranty.

The use of the unit has been projected for the applications specified in the technical characteristics. Exceeding the indicated values cannot in any case be authorized.

TELEDYNE OLDHAM SIMTRONICS recommends regular testing of fixed gas detection installations (read Chapter 7.2).

Before any intervention on the detector, please refer to the EN 60079-29-2 standard.

## Warranty

Under normal conditions of use and on return to the factory, MultiXplo and MultiTox detectors carry a 2-years warranty excluding accessories such as tilt mount, weather protection, etc.

## Waste Electrical and Electronic Equipment (WEEE directive)

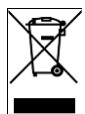

**European Union (and EEA) only.** This symbol indicates that, in conformity with directive DEEE (2002/96/CE) and according to local regulations, this product may not be discarded together with household waste.

It must be disposed of in a collection area that is set aside for this purpose, for example at a site that is officially designated for the recycling of electrical and electronic equipment (EEE) or a point of exchange for authorized products in the event of the acquisition of a new product of the same type as before.

# Table of Contents

<b>1</b>	<b>Product description</b> .....	<b>1</b>
1.1	Application Fields.....	1
1.2	DG-TX7-X.....	2
1.3	DG-TT7-K.....	2
1.4	Technical specifications.....	2
1.5	Detection Cartridge.....	4
1.6	Communication Interface.....	4
1.7	Product Code.....	6
<b>2</b>	<b>Technical features</b> .....	<b>9</b>
<b>3</b>	<b>Performances</b> .....	<b>13</b>
<b>4</b>	<b>Installation</b> .....	<b>15</b>
4.1	Positioning.....	15
4.2	Assembly.....	15
4.3	Electric Connection.....	18
4.4	Detection cartridge.....	26
<b>5</b>	<b>Commissioning</b> .....	<b>27</b>
5.1	Visual inspection.....	27
5.2	Power-up.....	27
5.3	Operational tests.....	27
<b>6</b>	<b>Operation</b> .....	<b>29</b>
6.1	Environmental conditions.....	29
6.2	Inhibition.....	29
6.3	Signal current loop.....	30
6.4	Alarm indication.....	31
6.5	Display indication.....	31
6.6	Wireless communication tool TLU600.....	33
6.7	Information menu [INFO].....	36
6.8	Adjustment menu [ADJT].....	37
6.9	Maintenance menu [MAIN].....	43
6.10	Ambiguity function in combustible gas detector smart sensors ....	44

6.11	Magnets operation.....	45
<b>7</b>	<b>Maintenance .....</b>	<b>47</b>
7.1	Power off / opening of housing.....	47
7.2	Periodic maintenance .....	47
7.3	List of main faults.....	49
7.4	Replacing the cartridge .....	50
7.5	Replacing the complete detector.....	50
<b>8</b>	<b>Certification .....</b>	<b>51</b>
8.1	Functional safety .....	51
8.2	ATEX / IECEx marking.....	51
8.3	Specific Conditions of use.....	52
<b>9</b>	<b>Accessories and spare parts.....</b>	<b>53</b>
9.1	Accessories .....	53
9.2	Spare parts.....	55
9.3	Gas table codes & range table codes .....	56

# 1 Product description

The DG-TX7-X is designed to monitor explosions risks induced by the presence of flammable gases or vapours (hydrogen, hydrocarbons, alcohol, etc.).

The DG-TT7-K is designed to monitor the gas concentration in %vol. induced by the presence of some special gases or vapours (hydrogen, helium, carbon dioxide, etc.).

The detector can be connected directly to a large range of traditional controllers or Programmable Logic Controllers (PLC).

The DG-TX7-X and the DG-TT7-K can be fully configured using the portable communication terminal (TLU600) in ATEX areas, providing flexibility to the user.

These detectors can be configured also using the magnetic wand or the Hart portable terminal TLH700 (in option).

The MultiXplo and MultiTox are also available for use in an addressable network system with distributed intelligence, SYNTEL. For more information, please refer to the Syntel module interface operating manual.

## 1.1 Application Fields

The DG-TX7-X and the DG-TT7-K are suitable for indoor and outdoor uses and offer a fast response time. Typical applications include:

- Storage and use of combustible/flammable gases and vapours (DG-TX7-X),
- Monitoring of processes with flammable products
- Hydrogen detection in inert atmosphere and in high concentration (DG-TT7-K),
- Chemical and petrochemical plants
- Pharmaceutical industry
- LNG/LPG
- Oil and gas facilities



### 1.2 DG-TX7-X

Detectors are calibrated on 100% LEL (Lower Explosive Limit) of a particular-gas or vapour.

The DG-TX7-X is a MultiXplo detector based on a thermo-catalytic oxidation transducer, which requires oxygen to function properly.

In the event of a long period without oxygen, the measurement will no longer be representative of the concentration of gases or vapours.

The characteristics of the device can also be altered by the presence of certain catalyst poisons such as silicone fumes, vapours of organometallic compounds and, to some extent by halogenated compounds.

### 1.3 DG-TT7-K

The DG-TT7-K is a MultiTox detector, based on catharometric transducer. Its measurement range is usually expressed in terms of %vol. relative to a particular-gas (for example 5%vol. H<sub>2</sub>, 5%vol. He...).

The DG-TT7-K measurement principle is based on the heat exchange between a heated filament and a "cold" separation. The effectiveness of the exchange between those two elements depends of the value of the thermal conductivity of the mixture which separate them.

This measurement principle is very stable, and able to operate with high gas concentrations.

In this configuration, the presence of oxygen is not essential, and catalytic poisoning is not an issue.

## 1.4 Technical specifications

Each detector is constructed as follows:

- A wall-mounted support secured by three screws and including cable gland (M20) (optional). There are 2 standard entries and an optional one.
- A stainless-steel explosion-proof housing containing:
  - A set of tropicalized electronic cards
  - A display and infrared communication electronic card allowing the communication with the remote control (TLU600)

- A colour coded cartridge, yellow for combustible gas detectors (DG-TX7-X) and brown for catharometers (DG-TT7-K), located in the lower part of the detector.

This cartridge is connected to the detector's body by an open ring leaving the label visible. A coloured ring enables the identification of the device type at a larger distance.

- A metallic support cable (optional) connects the wall mounting support and the housing, making the maintenance easier.

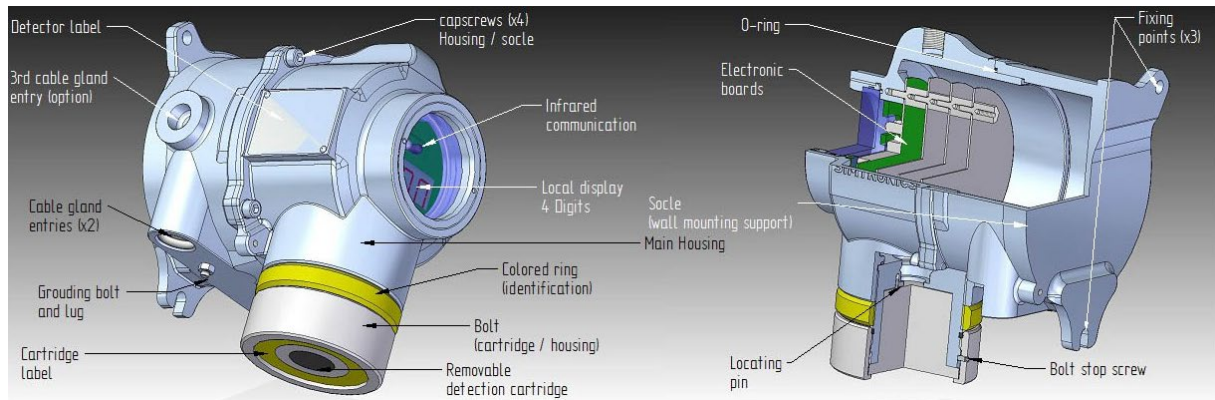

**Figure 1 : Layout Drawing**

(Outline drawing – see

**Figure 2)**



**Note:** there are some special versions using stand-alone Wheatstone ½ bridge probes as the SX202 type (product code: DG-TX7- \*\*DG-WXC-\*\*-000-0-\*-\*0)

Such version will be called « External probe versions » in the rest of the document

## 1.5 Detection Cartridge

Detection Cartridges are explosion proof designed.

They are common to all TELEDYNE OLDHAM SIMTRONICS MultiXplo and MultiTox-K products in order to reduce the number of spare parts.

- DG-RX7-X et DG-RT7-K: Network « Télécaptur » line
- DG-TX7-X et DG-TT7-K: « Télécaptur » line

For combustible gas detector's cartridges, if the difference between the storage temperature and the operating temperature does not exceed 20°C, the nominal characteristics are obtained after a few minutes. Otherwise, wait for the balancing thermal unit, about half an hour.

Catharometer cartridges (cartridges K) need to be in thermal balance with their environment to provide nominal performance. Thus, when the cartridges have been unpowered more than half-an-hour, a warm-up time is required when power is restored. The duration of warm-up is usually range from ½ hour to 4 hours, depending on the temperature difference between the cartridge and the ambient temperature.

The cartridge temperature information is available on the TLU.



The cartridge must not be unplugged when the detector is powered.

---

## 1.6 Communication Interface

### 1.6.1 Wireless Configuration Tool

Information and status of the detector are available via the wireless configuration tool TLU600.

Configuration and tests are performed using this wireless configuration tool (IrDA protocol). This tool is common for all TELEDYNE OLDHAM SIMTRONICS MultiFlame, MultiXplo and MultiTox products.

The TLU600 provides access to devices that, otherwise, would require major logistic operations for maintenance or for configuration (calibration ...).

For more details, please refer to the wireless configuration tool operating manual.



### 1.6.2 Magnetic wand

The detector includes two magnetic sensors PG1 and PG2 implanted on both sides of housing.

The communication interface is a magnetic wand. The wand gives access to information, state and configuration about the detector as the TLU (see §6.11).



## 1.6.3 HART communication

The HART communication authorizes an addressing of devices, allowing the communication in read/write mode.

It consists in getting connection on the current loop on which the numerical data are superimposed.

Most of the HART terminal can read these information and send commands

The use of a DD (Device Descriptor) facilitates the interface Man-Device. It can be uploaded on our website.

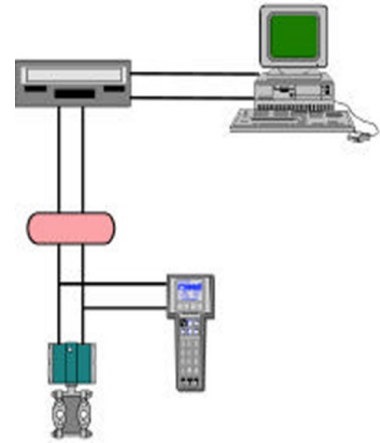

The HART output is an option. only available on the devices D, in HART configuration (H):**D**G**i**-\*\*7-\*\*\*\*-\*\***H**-\*\*-\*\*\*-\*\*-**D**-\*



TELEDYNE OLDHAM SIMTRONICS devices under HART protocol enable the use of all the functions available with the TLU600 via the HART terminal



See the document D1401002 for the using of Hart terminal TLH700 (the Detector Device Descriptor must be downloaded).

### 1.7 Product Code

Product codes are created from functional codes: **DG-<sup>\*\*</sup>7-<sup>\*\*\*\*</sup>-<sup>\*\*\*</sup>-<sup>\*\*</sup>-<sup>\*\*\*</sup>-<sup>\*</sup>-<sup>\*</sup>**

Detector type													
T	T	7	31	AF	-S	X	H	-C	0	-00J	-0	-C	-0
<b>C**</b>	Compact Sensor												
<b>T**</b>	Télécapteur												
<b>R**</b>	Network version												
<b>S**</b>	Replacement cell												
<b>X**</b>	Accessories												
Families													
<b>*T*</b>	Toxic												
<b>*X*</b>	Flammable gas												
<b>*0*</b>	None												
Version													
<b>**6</b>	BT606 housing												
<b>**7</b>	BT10 housing												
Gas type													
<b>**</b>	Refer to gas matrix												
Measurement range													
<b>**</b>	Refer to gas matrix												
Input Type													
<b>0**</b>	Not used or flame												
<b>E**</b>	Electrochemical												
<b>S**</b>	Semi-conductor												
<b>K**</b>	Catharometer												
<b>X**</b>	Catalytic												
<b>M**</b>	MECH												
<b>R**</b>	TOR input												
<b>C**</b>	Current input 0/22 mA												
<b>I**</b>	Infrared												
<b>W**</b>	½ Wheatstone bridge												
Variant													
<b>*A*</b>	Aluminium												
<b>*X*</b>	SS316												
Output Interface													
<b>**M</b>	1-2 mA protocol												
<b>**A</b>	0-22mA protocol (fault signalling in 0-4mA range)												
<b>**E</b>	4-20 mA protocol (Common fault signal 2 mA)												
<b>**H</b>	4 – 20 mA / 0-22 mA configurable & HART protocol												
<b>**C</b>	4 – 20 mA / 0-22 mA configurable												
<b>**W</b>	Wheatstone												
<b>**L</b>	LON												
<b>**X</b>	4 – 24 mA for compact explosimeter (magnet)												

DGi-TT7-E/O & DMi-TT6-E/O  
DG-TT7-S / DM-TT6-S

# MULTIXPLO AND MULTITOX DETECTORS

OPERATING MANUAL

T	T	7	31	AF	-S	X	H	-C	0	-00J	-0	-C	-0						
DGi-TT7-O / Dmi-TT6-O								<b>Cartridges</b>											
								O*						No cartridge or not specified or flame					
Dgi-TT7-E / Dmi-TT6-E / DGi-TT7-O / Dmi-TT6-O								M*						Electrochemical type M					
								G*						Electrochemical type G					
								Y*						Electrochemical type Y					
DG-TT7-X / DM-TT6-X								N*						Electrochemical type N					
								A*						Electrochemical type A					
								D*						Electrochemical type D7					
								X*						Catalytic					
DG-TT7-S / DM-TT6-S								S*						Semi-conductor (general designation for semiconductor type G)					
								F*						Semi-conductor type 30 (previously SF) since 2015					
DG-TT7-K / DM-TT6-K								C*						Semi-conductor type 31 since 2015					
								K*						Catharometer					
Half Wheatstone bridge probes								E*						EX05, EX09 (external)					
								L*						SX202-16					
								T*						SX202-10					
								U*						SX202-14					
								V*						SX202-17					
								H*						MTHX-S					
								J*						MTHX (/ , E, N, NE)					
								W*						SD122					
Z*						SD122-01													
DG-TT7-S / DM-TT6-S								<b>Semicond. Sensor type &amp; special configurations</b>											
								*O						Not specified or standard					
Options								*A						20					
								*B						23					
								*C						24					
								*D						25					
								*E						27					
								*F						30 (become obsolete to release *R association)					
Customized versions								*K						SD122 (EK)					
								*M						Special version MarED (TX6 and TV6 in type A only)					
								*R						With relay board for HW type D (gas)					
								*T						MTHX-S (ET)					
Customized versions								*X						SX202 (EX)					
								*1						Customized EPR (special follow up, SP4M20) (DM and DMi only)					
								*2						Customer T Customized version					
Customized versions								*3						Network electronic board authorizing HWA & STEL					

# MULTIXPLO AND MULTITOX DETECTORS

## OPERATING MANUAL

T	T	7	31	AF	-S	X	H	-C	0	-00J	-0	-C	-0
										<b>Configuration</b>			
										000	Standard		
										**A	Absolutely no grease		
										**B	Special version MarED (old code) (TX6 and TV6 in type A only)		
										**D	IRDA cap instead of display		
										**E	OV not connected to housing ground on Tox type C		
										**F	TCM02 instead of IRDA cap		
										**G	Paint for nuclear application : BT606 paint + special colour RAL5012		
										**H	Special paint : light grey (10A03 according to « British standards 4800/5252 »)		
										**J	Special paint : red (RAL 3001)		
										**K	Machining of additional cable gland input		
										*L*	Paint thickness > 200 µm(ATEX versionIIB)		
										M**	DGi without heating		
										<b>Language</b>			
										0	Fr / GB		
										F	French		
										E	English		
										P	Portuguese		
										C	Chinese		
										<b>Hardware version</b>			
										A	Type 63		
										B	Type 65		
										C	Type 67 (HART)		
										D	Type 69 (magnet)		
										<b>Software version</b>			
										0	Standard		
										1	Non-certified EN54-10 and/or SIL		

## 2 Technical features

### GENERAL

Type	Gas detector
DG-TX7-X	MultiXplo (catalytic gas detector)
DG-TT7-K	MultiTox (catharometer gas detector)
DG-RX7 or DG-RT7	Network detector
Calibration <sup>1</sup>	Recommended test every 6 months

### OUTPUT SIGNALS

4-20mA loop signal	Type active (source) maximum load impedance 700Ω
E version - « 4-20mA »	4-20mA with one fault level <ul style="list-style-type: none"> <li>• 0% full scale                    4 mA</li> <li>• 100% full scale                20 mA</li> <li>• 105% full scale                20.8 mA</li> <li>• Ambiguity function            21.7 mA (DG-TX7-X)</li> <li>• Fault or inhibition            1.5 mA</li> </ul>
A version - « 0-22mA »	4-20mA with several fault levels, for PLC and some recent control units <ul style="list-style-type: none"> <li>• 0% full scale                    4 mA</li> <li>• 100% full scale                20 mA</li> <li>• &gt;105% full scale               20.8 mA</li> <li>• Ambiguity function            21.7mA (DG-TX7-X)</li> <li>• Inhibition                        3.4 mA</li> <li>• Fault measure                  2.6 mA</li> <li>• Device fault (HW/SW)        2.0 mA</li> </ul>
Output relays	3 x configurable relays <ul style="list-style-type: none"> <li>○ max 1.7A / 35V<sub>AC/DC</sub> (in option)<sup>2</sup></li> <li>○ min 10mA / 20mV<sup>3</sup></li> </ul>

<sup>1</sup> These frequencies of calibration control are provided for information purposes only. The frequency depends on the operating conditions, the experience and safety requirements.

<sup>2</sup> This value changes to 1A when the security function uses the relays and the SIL level is required.

<sup>3</sup> Umin and Imin extracted from manufacturer datasheet

# MULTIXPLO AND MULTITOX DETECTORS

OPERATING MANUAL

## ELECTRICAL

Power supply:	24VDC,(18 – 35 V DC versions DG-T#7) (18 – 30 V DC versions DG-R#7))
Consumption:	1.6 W typical, 5 W maximum <sup>4</sup> 3 W typical, 5 W maximum for network detector
Wiring:	0,5mm <sup>2</sup> (20AWG)-2,5mm <sup>2</sup> (13AWG).
MTBF:	237 888 hours (for both versions)

## ENVIRONMENT

Storage	Temperature: -40°C to +65°C Time: 2 years in « clean » atmosphere Pressure: 1013 hPa ± 20% Humidity: 95% HR (non-condensable)
Temperature range	-40°C to +65°C (with external probe versions, each element has his own temperature range)
Pressure	1013 Hpa ± 10%
Humidity	95% HR (non condensable)
Protection	IP66
RFI/EMI	EN 50270
Heating time (DG-TX7-X):	< 100 sec
Stabilisation time (DG-TX7-X):	< 190 sec

## PERFORMANCE (DG-TX7-X)

European	EN 60079-29-1 (except external probe versions)
----------	--

## EXPLOSION PROOF HOUSING



Material	stainless steel 316 L
Weight	4.0 kg stainless steel
ATEX/IECEX	Please refer to § 8.2

---

<sup>4</sup> Typical power: voltage 24 Vdc, current 4 mA, display brightness 20%  
Maximum power: voltage 35 Vdc, current 22 mA, maximum display brightness, relay card option

## FUNCTIONAL SAFETY

SIL certification according to iec/en 61508 part 1 to 7 standard

Detector	Data	Definition	Value for current output	Value for relay output <sup>5</sup>
MultiXplo DG-TX7-X 	$\lambda$	Failure rate per hour	$2.82 \times 10^{-6}/h$	$2.78 \times 10^{-6}/h$
	SFF	Safety fraction failure (T1= 12 months)	90.5%	86.7%
	PFD*	Probability of failure on Demande	$1.21 \times 10^{-3}$	$1.67 \times 10^{-3}$
	PFH	Probability of failure / h (1oo1)	$2.67 \times 10^{-7}$	$3.7 \times 10^{-7}$
	MTTR	Mean Time To Repair	1440 min	
	SIL compliance	HFT = 0 / G.Fixed / 30°C / type B	2	1
MultiXplo DG-TT7-K 	$\lambda$	Failure rate per hour	$2.82 \times 10^{-6}/h$	$2.78 \times 10^{-6}/h$
	SFF	Safety fraction failure (T1=12 months)	98.7%	95.0%
	PFD*	Probability of failure on Demande	$2.06 \times 10^{-4}$	$6.59 \times 10^{-4}$
	PFH	Probability of failure / h (1oo1)	$3.71 \times 10^{-8}$	$1.41 \times 10^{-7}$
	MTTR	Mean Time To Repair	1440 min	
	SIL compliance	HFT = 0 / G.Fixed / 30°C / type B	2	2

\* Frequency of the SF verification: please refer to §7.2

\* Means of the SF verification: please refer to §7.2.3

<sup>5</sup> When the relays are in factory configuration: please refer to section 6.8.6.1

DIMENSIONS

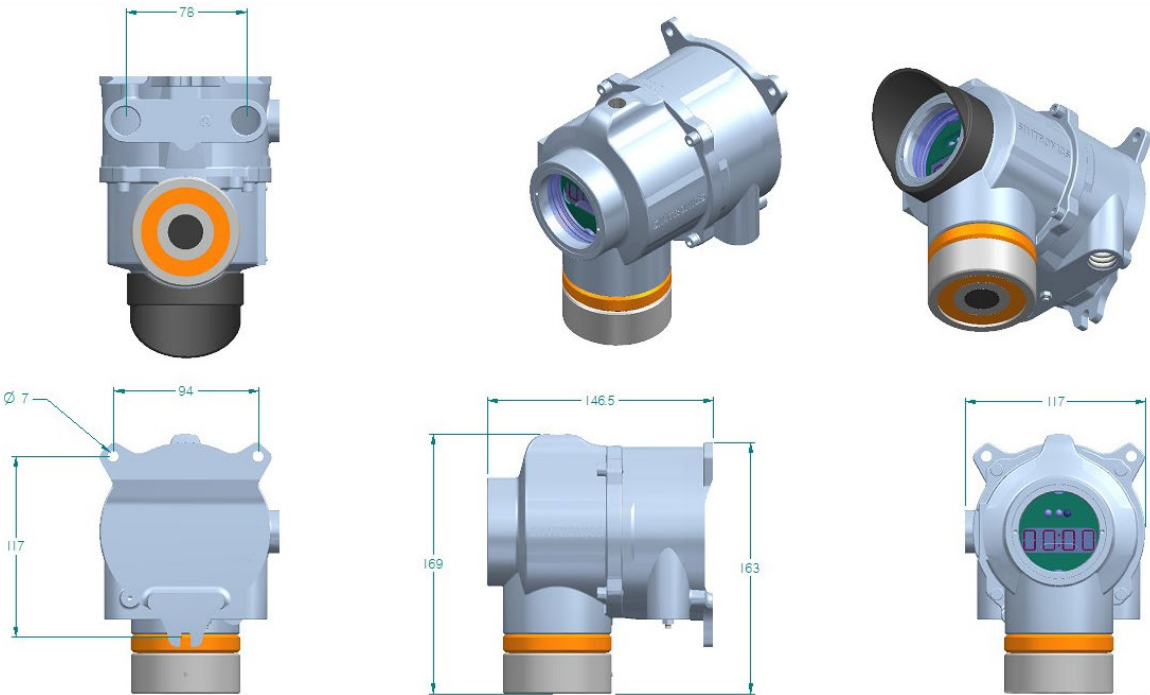

**Figure 2: Outline drawing (mm)**  
(Version with SX202: height dimensions = 190 mm)

### 3 Performances

Expected lifetime in standard conditions:

- >5 years for DG-TX7
- >10 years for DG-TT7-K

This lifetime can be reduced in case of exposure to dusty environments.



For catalytic version, some compounds are known to poison sensors. These include, organometallic, silicone and some halogenated compounds

PERFORMANCES	DG-TX7-X			DG-TT7-K	
	CH4	H2	C4H10	H2	He
Detector					
Ranges	100 % L.E.L. (5.0 %vol)	100 % L.E.L. (4.0 %vol)	100 % L.E.L. (1.9 %vol)	5%vol 20%vol 100%vol	5% vol 20% vol 100% vol
Relative sensibility	1.70 ①	1.70 ①	1.00 ①		
$\tau$ (0-50%) (sec) ②	< 10	< 5	< 10		
$\tau$ (0-90%) (sec) ②	< 15	< 10	< 20	< 10	< 10
Zero point stability ②	< 3	< 3	< 3	< 3	< 3
Sensibility drift ②	< 3	< 3	< 3	< 3	< 3
T° range (°C) ②	-40 / +65	-40 / +65	-40 / +65	-40 / +65	-40 / +65
Temperature zero drift ②③	< 2	< 2	< 2	< 3	< 3
Temperature sensitivity drift ②③	< 3	< 3	< 3	< 3	< 3
Linearity ②	< 3	< 1	< 3	< 2	< 2
Repeatability ②	< 1	< 1	< 1	< 1	< 1
Expected service life ④	>5	>5	>5	10	10
Relative humidity (% HR)	0 – 95 % condensation free			15 – 95 % condensation free	
Pressure range	Pa±10%				
Cross sensitivity	All inflammable compounds ⑥			All gases with either very high or very low thermal conductivity	
Poisons	Silicon compounds, certain halogen compounds, and some organometallic compounds.			None	
Effect of O <sub>2</sub> -enriched or depleted atmospheres	15 % O <sub>2</sub> min.	10 % O <sub>2</sub> min.	15 % O <sub>2</sub> min.	None	
Biasing time ⑤	90 sec			120 sec	

# MULTIXPLO AND MULTITOX DETECTORS

## OPERATING MANUAL

- ① Measured at 50% LEL of the considered gas
- ② In % full scale
- ③ On the range: -10°C to +40°C.
- ④ (In years) Expected values based on "typical" site operating conditions without poison or corrosive compounds.  
Lifetime can significantly vary (better or worse) depending on real site conditions.
- ⑤ Measure available but full performance may require longer time. See Chapter 2.
- ⑥ As soon as a gas or vapour is flammable, it is may be sensed by the combustible gas detector. Sensitivity (regarding LEL range) and the response time depend on the compound. Basically, as the molecule size increase, the response time increase and the sensitivity decrease.

Table below gives some examples of cross sensitivity:

Detector	CH <sub>4</sub>			H <sub>2</sub>			C <sub>4</sub> H <sub>10</sub>		
	CH <sub>4</sub>	H <sub>2</sub>	C <sub>4</sub> H <sub>10</sub>	CH <sub>4</sub>	H <sub>2</sub>	C <sub>4</sub> H <sub>10</sub>	CH <sub>4</sub>	H <sub>2</sub>	C <sub>4</sub> H <sub>10</sub>
Injected gas	CH <sub>4</sub>	H <sub>2</sub>	C <sub>4</sub> H <sub>10</sub>	CH <sub>4</sub>	H <sub>2</sub>	C <sub>4</sub> H <sub>10</sub>	CH <sub>4</sub>	H <sub>2</sub>	C <sub>4</sub> H <sub>10</sub>
Cross sensitivity*	1	0.95	1.7	1.06	1	1.7	0.57	0.54	1
τ(0-90%) (sec)	<15	<10	<20	<15	<10	<20	<15	<10	<20

If CH<sub>4</sub> (50% LEL) is injected on a H<sub>2</sub> detector, the concentration displayed will be 47.2% (50/1.06)\*

- ⑦ For external probe versions, temperature range is limited to -20 / +60 °C
- ⑧ Under conditions of natural diffusion and available on any of the outputs of the device (HART, 4-20mA, ...).

## 4 Installation

The detectors described in this manual are safety instruments intended to be installed in explosive atmospheres and have been designed in compliance with standards EN60079-0 and EN60079-1, EN 60079-29-1, CEI 60079-0 and CEI 60079-1.



Intervention in some sites may be subject to restrictions that we invite you to follow for your own safety and those of others.

---

### 4.1 Positioning

The detector must be positioned as close as possible to sources of potential leakages, considering airflows (e.g. upper and lower ventilation). The height is determined by the density of gas to detect.

A detector will not be placed in front of an air inlet which brings clean air

This height may be adjusted to consider the specific conditions which may interfere on the risk level (gas density, ambient temperature....)



There are no limit positions of the detector however it is recommended to position the detector vertically (ie with the cartridge pointing downwards).

---



Air velocity limits: 6 m/s.

---

### 4.2 Assembly

Use the two 7 mm diameter holes and the half-slotted hole to secure the support.

It is highly recommended to install the support with cable-gland downward in order to avoid water infiltrations. In case of horizontal position, it is advised to make one or two loops with the cable at the entry of the cable-gland.

When mounting the cable gland (optional), if no tightening torque is specified by the manufacturer, consider that a tightening torque of 20N.m +/-10% is the most suitable.

On stainless steel housings, plugs are sealed with Loctite. If the plugs are moved or removed, it must be sealed again, using Loctite or equivalent.

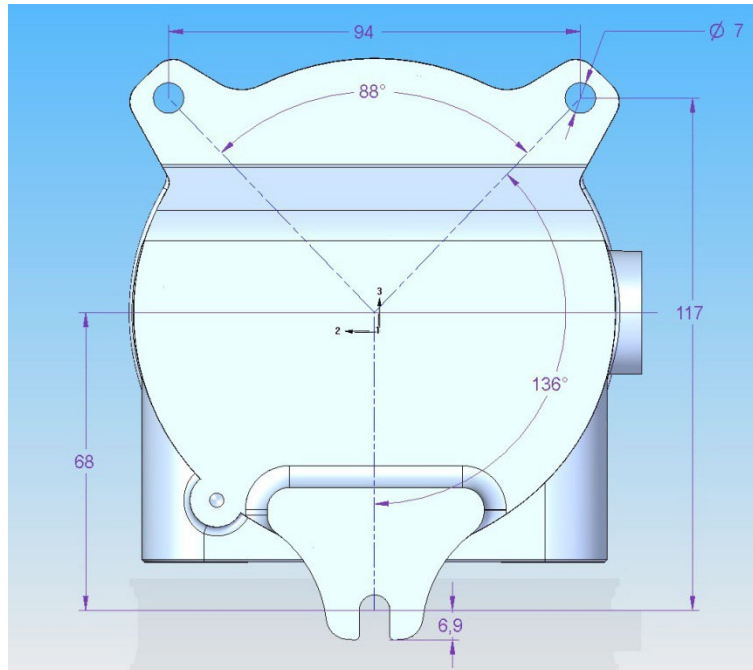

Figure 3: Drilling dimensions for support fixing.

### 4.2.1 Detector assembly

Check the presence and the good condition of the O-ring on explosion proof seal (no cracks, no cuts, good elasticity), make sure the flameproof joint is correctly greased and has no visible damage.

Plug connectors to the base, as described in paragraph 4.3.

Fit the main housing on the base, placing the cable excess in the base. Put in place and tighten the four M5 screws with their grower rings.

It is possible to set up a suspension cable (not supplied) between the base and the housing (at the lower part) with two threaded holes (M4 x 6).



Only the screws of property class A4-70 (yield stress  $\geq 450\text{MPa}$ ) must be used as a special fastener.

## 4.2.2 Cable inputs



Connection cables must pass through a cable gland (Explosion Proof certified) as an option

---

For installation details, refer to the instructions provided by the manufacturer of the cable gland used.



The unassigned cable glands entries must be blanked with explosion proof certified plugs (M20). They are glued with Loctite® (type *tubétanche 577*) or equivalent compound. If a plug is moved or removed, it must be glued again with Loctite or an equivalent.

---

## 4.2.3 Communication using the TLU 600

Communication elements are located above the display.



The orientation enables a communication with  $\frac{1}{2}$  horizontal angle about  $35^\circ$ ,  $\frac{1}{2}$  vertical-up angle about  $30^\circ$  and a vertical-down angle about  $50^\circ$

### 4.2.4 Magnets identification

The magnets are identified by two stickers "PG1" and "PG2" fixed on the housing.

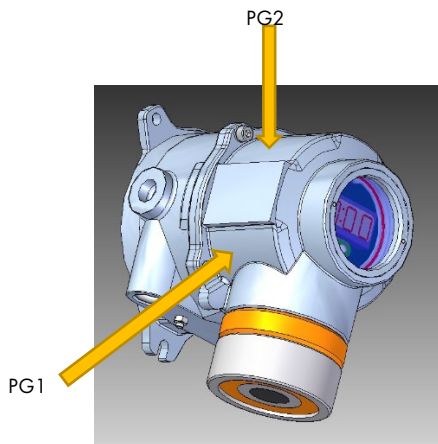

### 4.3 Electric Connection



Never adjust electrical connections when detectors are powered. Maintenance must be undertaken by qualified staff. Observe safety site rules.

The MultiXplo and MultiTox are sensors with standard current output 4-20mA or 0-22mA. The connection can be on 3 or 4 wires. The 4 wires configuration allows insulation between the signal and power loops.

We recommend using an armoured and shielded cable, type NF M 87 202, in accordance with the requirements for hazardous areas and NF C 15 100. Other cables can be used if they are compliant with the local regulations and standards.

The table below shows the maximum cable lengths based on the wire cross section and the supply voltage delivered by the detection unit.

Min. single wire cross section mm <sup>2</sup> /AWG	0.5 (20)	0.9 (18)	1.5 (16)	2.5 (13)
Supply voltage 24VDC	288 m	505 m	893 m	1000 m
Supply voltage 24VDC -10%	173 m	303 m	536 m	926 m

NB: Those values are calculated for a minimum supply voltage of 18VDC at the sensor level and for the maximum consumption of the detector (5W)

### 4.3.1 Connection of the electrical ground braid

Use a shield connection clamp (not supplied) to connect the shielding of the cable to the electric ground of the housing (see § below).

### 4.3.2 Grounding

A M4 screw passes through the body of the enclosure, enabling the electronic ground of the housing to be connected to the local ground.

The armour of the power cable is normally connected to the ground of the detector, but it may depend on site practices.

The external earth connection must be made in accordance with the regulations in force.



### 4.3.3 Connection

There are three different cabling:

- 3-wires connection (source):
  - The output current is not isolated from power supply, provided from detector (standard connection).
- 3-wires connection (sink):
  - The output current is not isolated from power supply, consumed by the detector
- 4-wires connection:
  - The output current is isolated from power supply

---

NB: The power potentials are isolated from the electric ground of the housing.

---

#### Total loop resistance:

Whatever the power supply type (3 wires source or sink, 4 wires), the total loop resistance (resistor + cable) should not exceed the following value:

$$R_{\text{maxi}} = \frac{\text{Power supply voltage} - 8V}{22\text{mA}}$$

The total loop resistance should not exceed 700  $\Omega$  with a voltage of 24Vdc

### Terminal blocks:

Point	JP11	Description
1	V-	0 V retour
2	V+	+24VDC power supply
3	V+	+24VDC power supply loop (connected to point 2)
4	V-	0 V, connected to point 1
5	L+	20mA loop : input
6	L-	20mA loop : output

#### 4.3.3.1 3-wires connection (source)

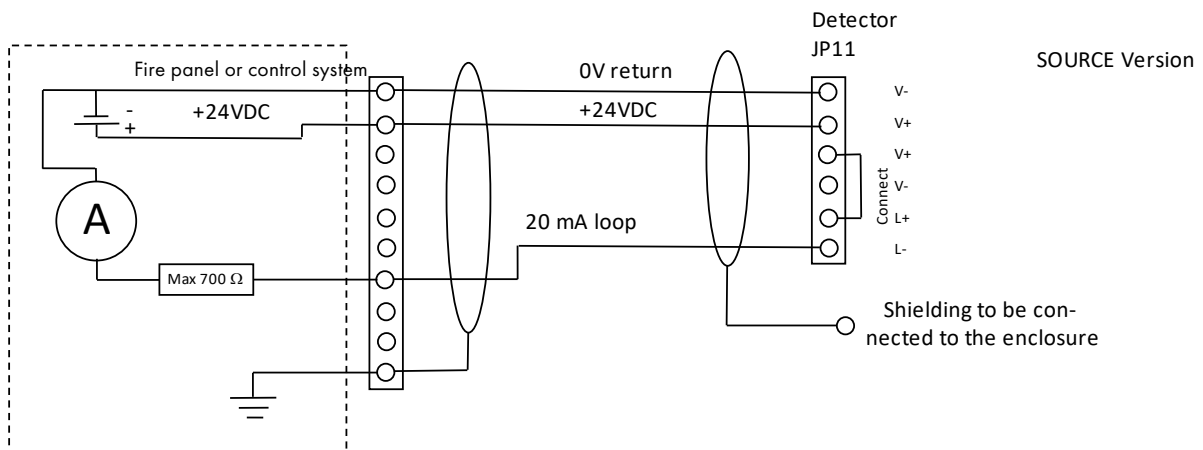

In this case, the output current is not isolated from power supply, provided from detector (standard connection).

The 20mA current loop must be supplied with 24 V at terminal L+. To proceed, connect the 3 (V+) and 5 (L+) terminals at the terminal block level of the device.

#### 4.3.3.2 3-wires connection (Sink)

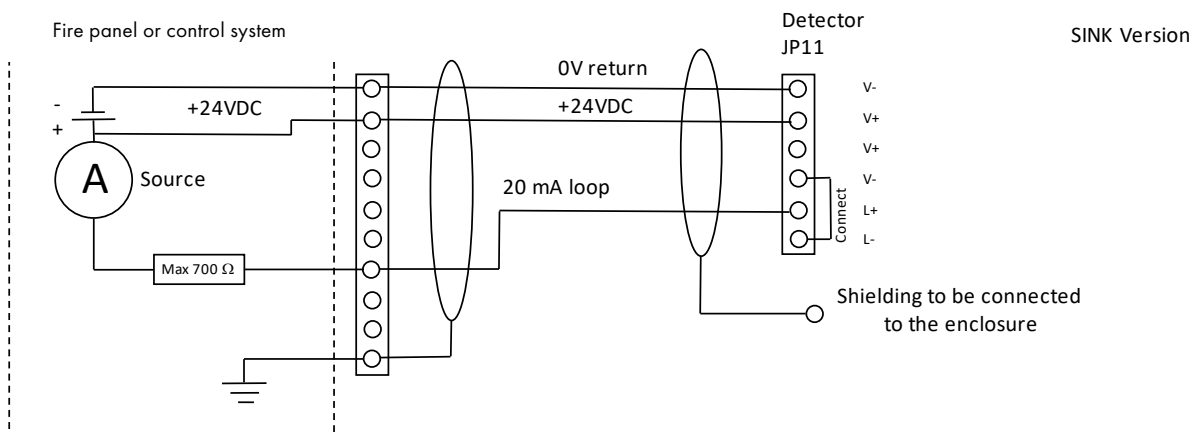

In this case, the output current is not isolated from power supply, consumed by the detector.

The 20mA current loop must be supplied with a PLC. The current return must be connected to the 0V at the level of the L- terminal. To proceed, please connect the 4 (V-) and 6 (L-) terminals at the terminal block level of the device.

### 4.3.3.3 4-wires connection (isolated power)

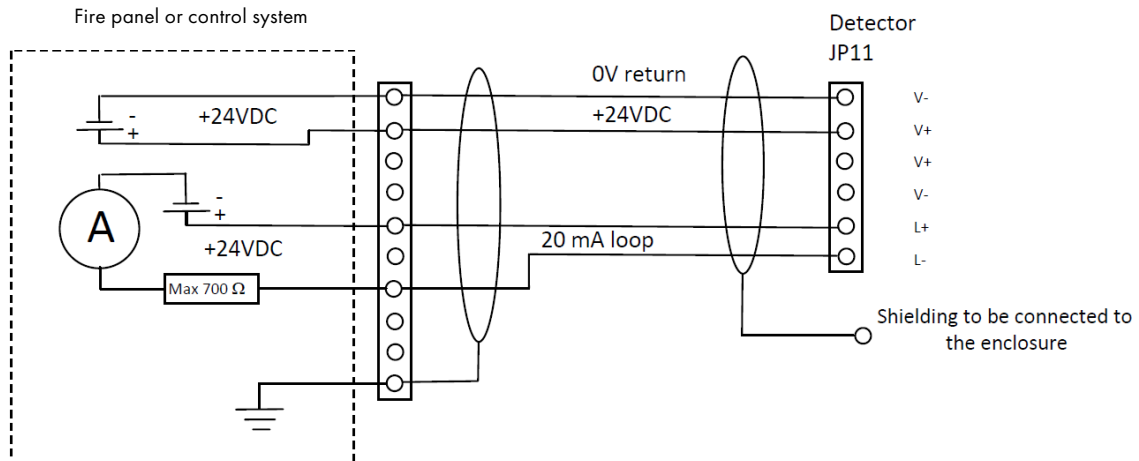

When using a 4 wires connection, the current loop is provided by the input module or PLC. The loop (L + and L-) is optically isolated from the detector. 4-20mA or 0-22mA input module of the PLC must power up the current loop with, at least 8V at the terminal level.

### 4.3.4 Relay (option)

An optional card with 3 relays can be added on the detector.

The output relays can be connected to the detection unit or warning devices.



For the network version, the optional relay card cannot be installed.

Each relay can be configured:

- normally closed or normally open.
- on one or more states of the detector (fault, permanent Inhibition, alarms).

Relays configured at factory setting: refer to § 6.8.6.1

Relay card, terminal block (option):

Point	JP2	Description
1	C1	Relay 1 common
2	R1	Relay 1 de-energized
3	T1	Relay 1 energized
4	T1	Relay 1 energized
5	C2	Relay 2 common
6	C2	Relay 2 common
7	R2	Relay 2 de-energized
8	T2	Relay 2 energized
9	T2	Relay 2 energized
10	C3	Relay 3 common
11	R3	Relay 3 de-energized
12	T3	Relay 3 energized

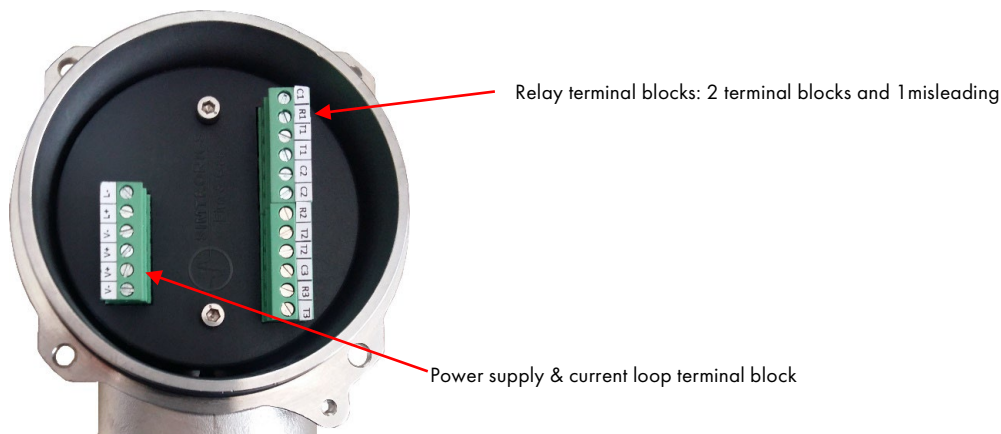

### 4.3.5 EOL Resistor



This applies to ATEX/IEC installations only. The EOL resistor must only be used inside the housing on the terminal block.

The EOL resistor allows to a detection unit equipped with the line control function to ensure the continuity of the relay cable.

The EOL resistor must be placed on the relay contact connector to be monitored.

Maintain a 10mm minimum gap between the resistor and the terminal block or any other neighboring parts.

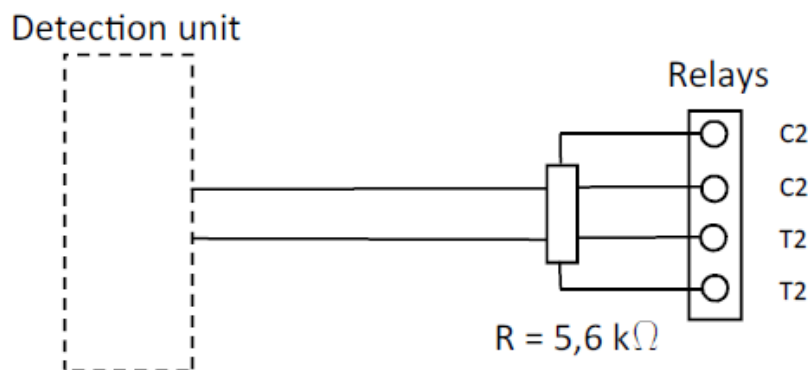

NB:

The R1 value is given as an indication. It must comply with the following conditions:

- Minimum consumption = 5 Watts
- Maximum dissipation = 2.5 Watts

## 4.3.6 Syntel connection

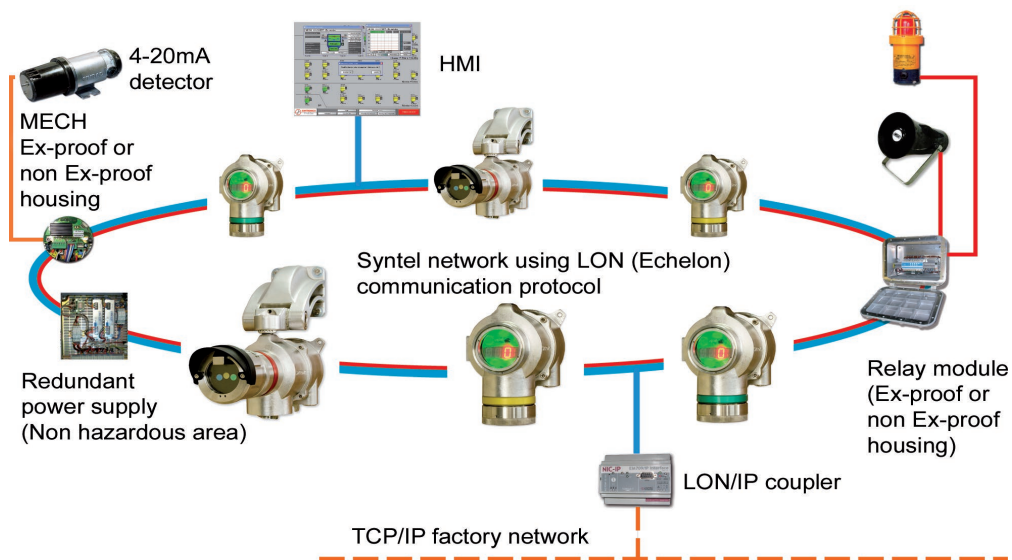

In this network version, an electronic board is inserted in the detector body and is used for electric connection.

Connecting the ground terminal should be performed thanks to 3-wire shielded cables.

The connection of power supply wires (4 on side A and 4 on side B).

- Two red wires on V +: +24 V
- Two white wires on V -: 0 V

Connection of the media wires (2 on side A and 2 on side B)

- A red wire on one of the N
- A white wire on the other N (no specific edge)

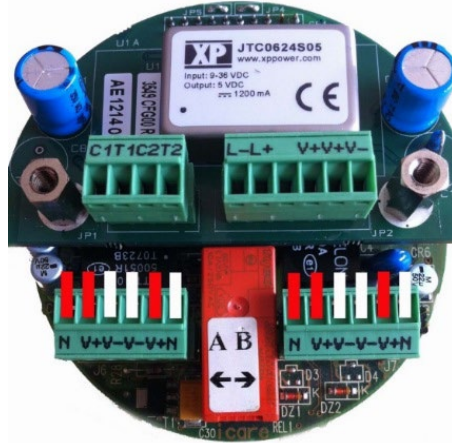

Figure 4: Connecting drawing of the network versions



On board relays are not available on the digital version of the detectors

For more detail, thanks to refer to the operating manual NOSP 15251

### 4.3.7 0-22mA input connection

The device enables to use a 0-22mA input from another sensor. The device is designed as :

DG- \*\*7-\*\*\*\*-C\*\* -\*\* -\*\*\* -\*-D-\*

RS485 :  
Terminal block  
not used

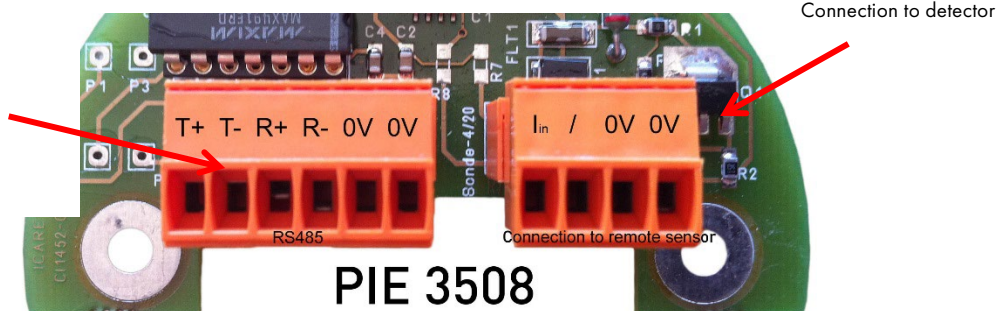

In that case, an input of the cable gland or an accessory in replacement of the cartridge enables the connection between the hosted sensor and the device.

In order to operate this analog input, an additional electronic card (PIE 3508 or PIE 3509) is added above the numeric card



The hosted sensor NEEDS to get its own power

The connecting wires to another detector are limited to a 1 mm<sup>2</sup> section.



Using this board leads to a connection between 0V from power supply and housing ground

## 4.3.8 Half bridge explosimeter input

It is possible to configure a device with an Ex05 remote explosimeter probe or a SX202 as an external probe. In the below configuration, the input is of type Combustible Gas Detector (X) and the cartridge is of type E.

With half bridge explosimeter probe (SX202, MTHX, SD122), the device is designed as:

DG-\*\*7-\*\*\*\*-W\*\*-#\*-\*\*\*-\*--D-\*

With the external half bridge explosimeter detector (EX05, EX09), the device is designed as:

DG-\*\*7-\*\*\*\*-W\*\*-E\*-\*\*\*-\*--D-\*

In that case, an input of the cable gland enables the connection between the hosted sensor and the device.

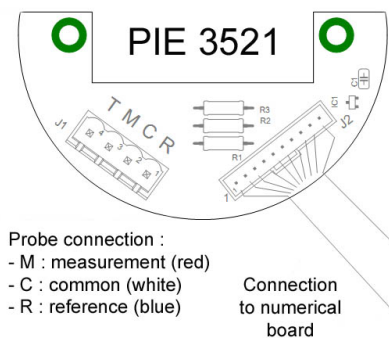

In order to operate this analog input, an additional electronic card (PIE3521) is added above the numeric card.



Using this board leads to a connection between 0V from power supply and housing ground

The wire cross section must be between 0.9 and 2.5mm<sup>2</sup>.

The table below shows the maximum cable lengths based on the wire cross section:

Min. single wire cross section mm <sup>2</sup> /AWG	0,5 (20)	0,9 (18)	1,5 (16)	2.5 (13)
Maximal Length	/	15 m	30 m	50 m

## 4.4 Detection cartridge

The cartridge is separated from the detector to enable its replacement. Its dismantling is extremely easy and does not need to touch the rest of the unit.



Caution during the assembly and the disassembly of the cartridge on the detector:

Slide the positioning pin of the cartridge into the corresponding hole in the housing (at the bottom of the receiver).

Take care to not damage the cartridge connector when tightening the two parts.

This operation imperatively requires power to be off



Loosen the locking screw on the side of the nut (see Figure 1), then unscrew the nut, along the first part of the thread. With the nut, pull on the cartridge to remove it and then unscrew the cartridge from the nut.

Cartridges have an identification colour ring (see §1.4).

Insert a new cartridge of the same colour into the case respecting the position defined by the centring pin, screw the nut until it stops ensuring the presence of O-ring. Then, tighten the locking screw.

Switch on the device in order to make the calibration of the new cartridge and the zero adjustment.

## 5 Commissioning

### 5.1 Visual inspection

Make certain that all the operations of the "Installation" chapter have been achieved correctly.

Pay particular attention on installation conformity, check the cables entry, the presence of O-rings, and the connection of the cartridge.

- The label on the smart sensor indicates the type of detector, the type of gas and the range for which the instrument has been calibrated
- The cartridge colour must correspond to the type of detector:
  - Yellow for combustible gas
  - Brown for catharometer

### 5.2 Power-up

The detector is powered through the multichannel detection unit or the Programmable Logic Controller.

- The backlight turns violet
- The display (red) appears. It displays, among other information, the INH which indicates the start-up inhibition and the warming up remaining time in *min* and *sec*.
- After this warming up time, the backlight turns green and the current concentration is displayed.

### 5.3 Operational tests

All MultiXplo / MultiTox detectors are delivered set and tested. Some additional tests are necessary to check the good working of the loop. Please make sure to have all authorizations needed before running the following operations:

- Check the states/information using the TLU600 or TLH700 (hart) or the magnetic wand,
- Check the alarm levels
- Zero point: If there are no polluting gases or, if necessary, by injecting clean air at 30 l/h using the calibration kit equipped with an air cylinder
- Sensitivity: By injecting a suitable gas mixture at 30 l/h using the calibration kit
- Check the servo controls

# MULTIXPLO AND MULTITOX DETECTORS

OPERATING MANUAL



## 6 Operation

### 6.1 Environmental conditions

The lifetime of the catalytic cartridge depends on the operating environment related to certain pollutants.

Take care to avoid exposures to some vapours products as silicone (vapours of some paintings, some seals ...), halogenated products (molecules containing one atom of chlorine, fluorine, bromine) or as sulphur ones (H<sub>2</sub>S...).

### 6.2 Inhibition

Maintenance Inhibition is temporary. It appears during power up and maintenance phases. Inhibition stops automatically when the operator gets out of the maintenance menus or 10 minutes after the end of communication with the TLU.

Maintenance inhibition can be configured in "frozen" mode (Factory setting) or in "free" mode with the TLU or TLH700. It cannot be configured by the magnetic wand.

- In "frozen" mode, outputs (current and relay) remain in their previous state.  
For example, if the device indicated a fault, this state would be maintained during the inhibition.
- If the unit is configured in "free" inhibition mode, the output current will be on the same level as for the permanent inhibition

The permanent inhibition is activated by an order issued by the TLU, the TLH700 or the magnetic wand when an operation is performed at or around the device, or when the operator wants to inhibit a faulty device. The permanent inhibition must be removed by an operator's deliberate action using the TLU, the TLH700 or the magnetic wand.



As for the maintenance inhibition, this special mode is leading to a purple color on the display.

---

## 6.3 Signal current loop

State	"4-20" [mA]	"0-22" [mA]	Display	TLU state
Line fault	0.0	0.0	DEF yellow Backlight	DEF
Configuration fault	1.5	2.0	DEF yellow Backlight	DEF
Detector fault (electronic)	1.5	2.0	DEF yellow Backlight	DEF
Measure fault	1.5	2.6	DEF yellow Backlight	DEF
Start inhibition	1.5	3.4	INH violet Backlight	Warming-up remaining time including power up
Permanent inhibition	1.5	3.4	INH violet Backlight	INH
Maintenance inhibition Fixed configuration (fault) / ("free mode") *	Previous value/ (1.5)	Previous value/ (3.4)	INH violet Backlight	INH
Alarm verification	21.7	21.7	DEF red Backlight	100% - DOUT DEF
≤ -10% of full scale	1.5	2.0	DEF yellow Backlight	DEF
-10% < concentration ≤ 0% of full scale (negative concentration not activated)	4.0	4.0	0% green Backlight	0%
-10% < concentration ≤ 0% of full scale (negative concentration activated)	2.4 < I ≤ 4.0	4.0	-10% < mes ≤ 0% green Backlight	-10% < mes ≤ 0%
0% of full scale	4.0	4.0	0% green Backlight	0%
25% of full scale	8.0	8.0	25% red Backlight if alarm reached green Backlight if alarm not reached	25% Alarm if level exceeded
50% of full scale	12.0	12.0	50% red Backlight if alarm reached green Backlight if alarm not reached	50% Alarm if level exceeded
75% of full scale	16.0	16.0	75% red Backlight if alarm reached green Backlight if alarm not reached	75% Alarm if level exceeded
100% of full scale	20.0	20.0	100% red Backlight	100% Alarm
≥ 105% of full scale	20.8	20.8	red Backlight	> 100% Alarm

(\* ) Maintenance inhibition may be available in frozen or free mode.

**Display time:**

The detector displays concentration or status. Depending on events, the detector displays cyclically important information according to the context: unit, gas, label, fault, alarms, inhibition and the time remaining inhibition....

**Output current (4-20mA ou 0-22mA) :**

It can be modified by the user. See §6.8.6.2.

**Negative concentration:**

The negative concentration display allows to anticipate the zero-drift fault. It can be modified by the user. See §6.8.8.

## 6.4 Alarm indication

When an alarm status is confirmed, the backlight turns red. Moreover, the display indicates the alarm level and the current concentration.

The remaining information which is usually recorded in the display cycle are not provided anymore, in order to keep the detection and current alarm level as a priority.

If the alarm memorization is enabled, the backlight light remains red and the alarm indication appears in the display cycle until the alarm is acknowledged with the TLU or the TLH700 or the magnetic wand or the detector is powered off, then powered on again.

If the alarm memorization is disabled, the backlight turns green when the alarm fades.



If the device is used in a safety loop in a potentially explosive area (EN60079-29-1), the upper alarm must be memorized, and a manual action must be taken to clear it.

---

## 6.5 Display indication

The 4 Digits display provides several information, depending on the state of the device:

**Starting:**

- Display cycle: concentration and measuring scale (25 then % then LIE then CH4, for example)
- Alternately indicates the inhibition mode and the warming up remaining time

### Normal operating mode:

The digital readout provides the following information:

- Concentration
- Measuring scale
- Abbreviation of the gas used
- Label of the device



### In case of alarm:

- The display of concentration flashes
- Alternation with « AL1 » or « AL2 » depending on the level



### In case of default:

- The display shows « DEF »



### In case of INHIBITION:

- The display shows « INH »



### If ambiguity is acknowledged (DG-TX7-X):

- Display indicates « 100 » and the status is «OVER»

### The modes of the backlight are:

Green	Normal use, no alarm
Red	Superior to the alarm level 1 and/or ambiguity Acknowledgement
Yellow	Fault mode
Violet	Inhibition mode ; maintenance (temporized or permanent)



At factory setting, the intensity of the backlight and the display self-adapt, depending on the brightness of the environment. The brightness can be adjusted at fixed levels, between 0 (off) and 100%



The electric consumption of the device depends on the background light level.

## 6.6 Wireless communication tool TLU600

All settings and tests of detectors can be done by the wireless communication tool TLU600. This communication tool and its software are compatible with all TELEDYNE OLDHAM SIMTRONICS detectors: MultiFlame, MultiTox and MultiXplo. Communication is made via infrared link (IrDA), similar but more efficient than infrared links for computers. IrDA head should not be placed facing the sun as it significantly reduces the communication with the TLU600.

Please refer to the wireless communication tool operating manual for more details.



When a device is in communication mode with the TLU, its background light flashes. It enables the user to ensure he communicates with the requested device.

The TLU600 menu is composed of 2 access levels allowing both settings and obtaining information about detector's status.

- level 1: exploitation
- level 2: Maintenance

### 6.6.1 Main screen

The main screen is composed into several data fields.

C 1		C 2		C 3	C	
C 4					1	
C 5					0	
C 6		C 7		C 8		C 9

- C1: Detector name field
- C2: Field blank if normal operation; INH- if inhibited
- C3: Field blank if normal operation; FLT- if at least one fault has occurred
- C4: State of detection: no detection, cartridge fault
- C5: State of alarm: alarm, no alarm
- C6, C7, C8 and C9: Name of keys F1, F2, F3 and F4
- C10: Wireless communication tool pictograms

Main screen displays identity and state of the detector.

```
DG-TX7
      0% LIE C4H10
[0 ----- 100%]
INFO|ADJT|MAIN|FCNX
```

### 6.6.2 General operation

The user can navigate through the menu with the F1 to F4 keys, whose functions change depending on the fields displayed above each key. Standard functions:

- >>>> Scroll function / next screen.
- ESC Exit the current menu and return to the previous one.
- CHG Changing displayed value.
- VAL Validation and Check-in of the changed value.



The changed value must be confirmed by pressing [VAL] key, otherwise the old value will be kept when leaving the menu.

---

### 6.6.3 Menu structure

- Exploitation:  
This level enables access to the information and the status of the detectors. It does not allow the configuration operations or write access.
- Maintenance:  
The access to the parameters and other maintenance operations is protected by a password.  
Default password (6 digits which can be changed): 012345.

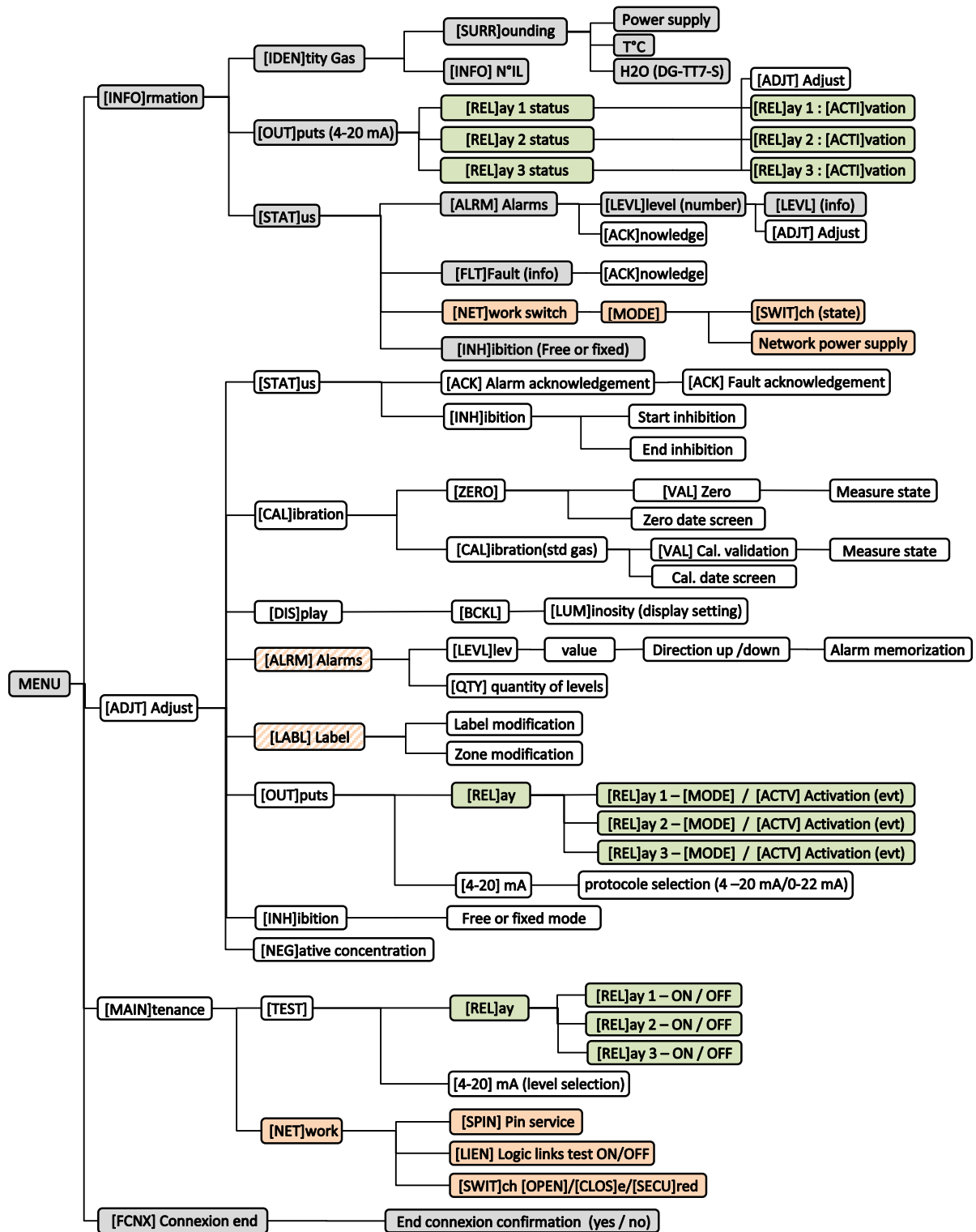

- Menus displayed without access code
- Menus displayed with relay board
- Menus displayed with Syntel board
- ▨ Menus not displayed with Syntel board

## 6.7 Information menu [INFO]

The information menu contains all information concerning the identity and settings of the detector. The first screen gives the detector's reference and its serial number.

### 6.7.1 [IDEN]tity submenu

Presentation of:

- The serial number
- The device reference
- The scale and the targeted gas

Sub-menus present the board software version, the power supply voltage and the temperature read in the cartridge.

### 6.7.2 [OUT]put submenu

Presentation of:

- Analogue output current type (0-20 mA or 4-20 mA).
- Normal state of the relays (normally open or normally closed).
- Condition of relays activation.

Relays can be set with a level 2 access.

### 6.7.3 [STAT]e Information submenu

Presentation of:

- Number and value of activated levels.
- List of eventual faults (press F1 key to scroll through the list)
- Possibility to acknowledge alarms
- Possibility to acknowledge ambiguity (DG-TX7)

#### 6.7.3.1 [ALRM] Alarm screen

Allows setting of levels and alarms acknowledgement.

#### 6.7.3.2 [FLT.] Fault screen

Displays a list of eventual faults (press F1 key to scroll through the list) and allows their acknowledgment.

#### 6.7.3.3 Network Screen Switch

This menu and its sub-menus are used for the network detector settings. For any further details, please refer to the Syntel system operating manuals.

### Mode screen

The first line shows the operating mode of the sensor in the network (logic link test/out of order/emulation).

The second line shows if the network part of the detector is "operating" or "out of order". For any further details, please refer to the Syntel system operating manuals.

### Network screen: alim

Information displayed:

- Voltage A: ON / OFF
- Voltage B: ON / OFF

For any further details, please refer to the Syntel system operating manuals

#### **6.7.3.4 [INH] screen**

This screen is dedicated to verify the inhibition mode configuration (frozen or free). If the access level permits it, it is possible to change this setting.

## **6.8 Adjustment menu [ADJT]**

This menu presents all the detector settings. All the functionalities, except alarm level acknowledgment, request access level 2.

### **6.8.1 [STAT]us sub-menu**

#### **6.8.1.1 Alarm Acknowledgement**

This menu enables the acknowledgement of the memorized alarms. The alarm can be acknowledged only if the alarm condition has disappeared.

#### **6.8.1.2 Inhibition / End of inhibition**

The inhibition (called permanent inhibition) is activated or deactivated manually using the menu. This function is used for deactivating the detector outputs (example: during maintenance).

The « inhibition » menu is available if the sensor is not in inhibition, maintenance inhibition or simulation.

Selecting the inhibition mode will switch the detector in inhibition mode.

The message "End of inhibition" is displayed on the TLU.

Press on "End of inhibition" to get the detector back to normal operating mode.

### 6.8.2 [CAL]IBRATION sub-menu

#### 6.8.2.1 Zero-point setting

The operator can set the zero point with the wireless communication tool TLU600.

The detector is in maintenance inhibition mode for 10 minutes after it goes back to main screen.

Use the setting menu and validate the INH command for acknowledgement.

Press F4 key to stop communication between TLU600 and the detector.

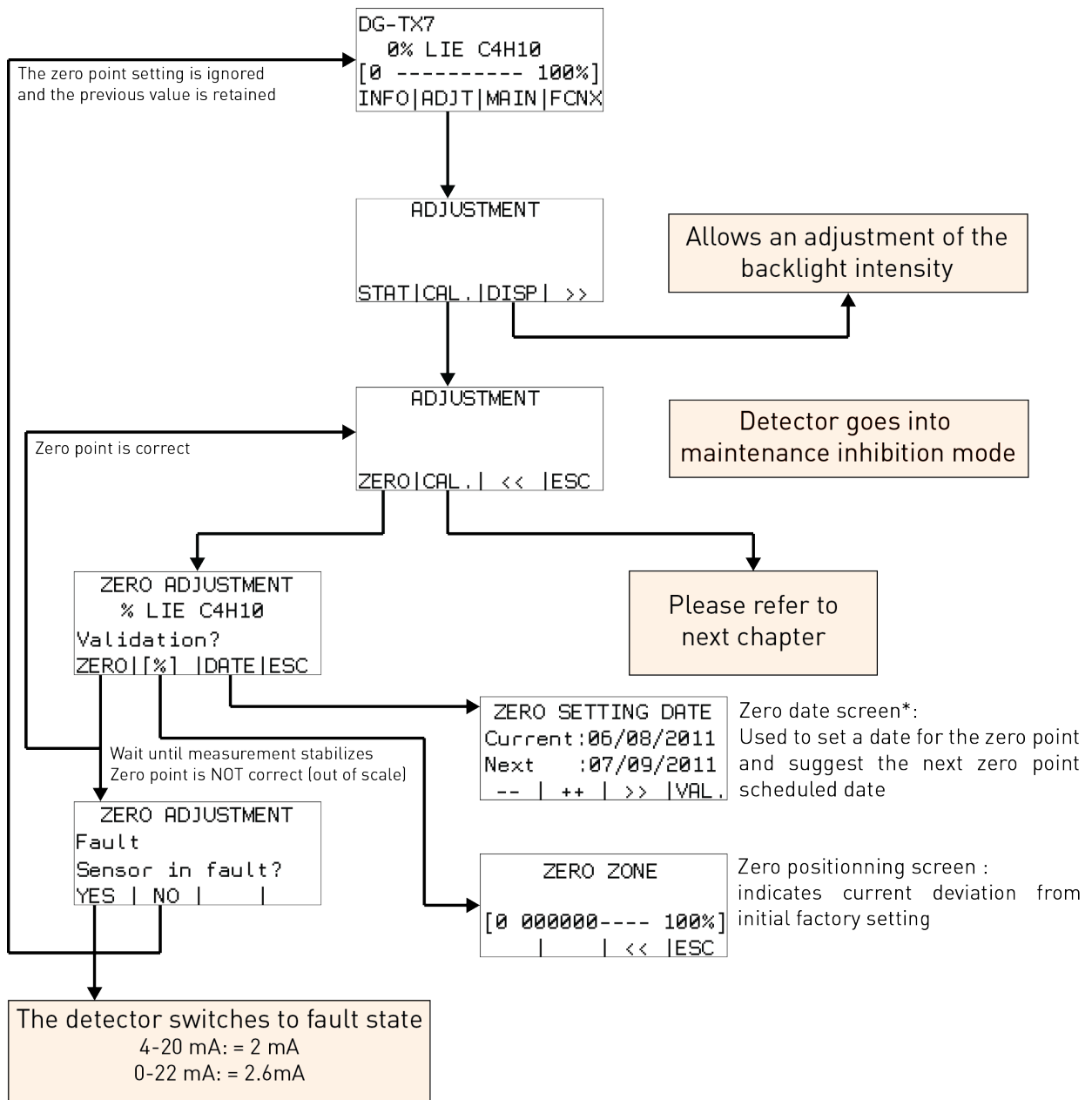

\* The device doesn't embed battery, it is then not able to keep real time. The date indication for zero or calibration points, as well as the next expected date for similar operations, are entered manually by the operator. Those data are for information only and their update is optional. mise à jour est facultative.

## 6.8.2.2 Calibration

Calibration must be made with the gas the detector is set to detect, with the SET menu (F2 key) of the wireless communication tool TLU600 and a calibration kit. The calibration gas should be injected at a flow rate between 30 l/h and 60 l/h.

The detector is in maintenance inhibition mode for 10 minutes after it goes back to main screen. Use the setting menu and validate the INH command for acknowledgement.

To end of communication between the TLU600 and the detector is done by pressing F4 key on main menu.

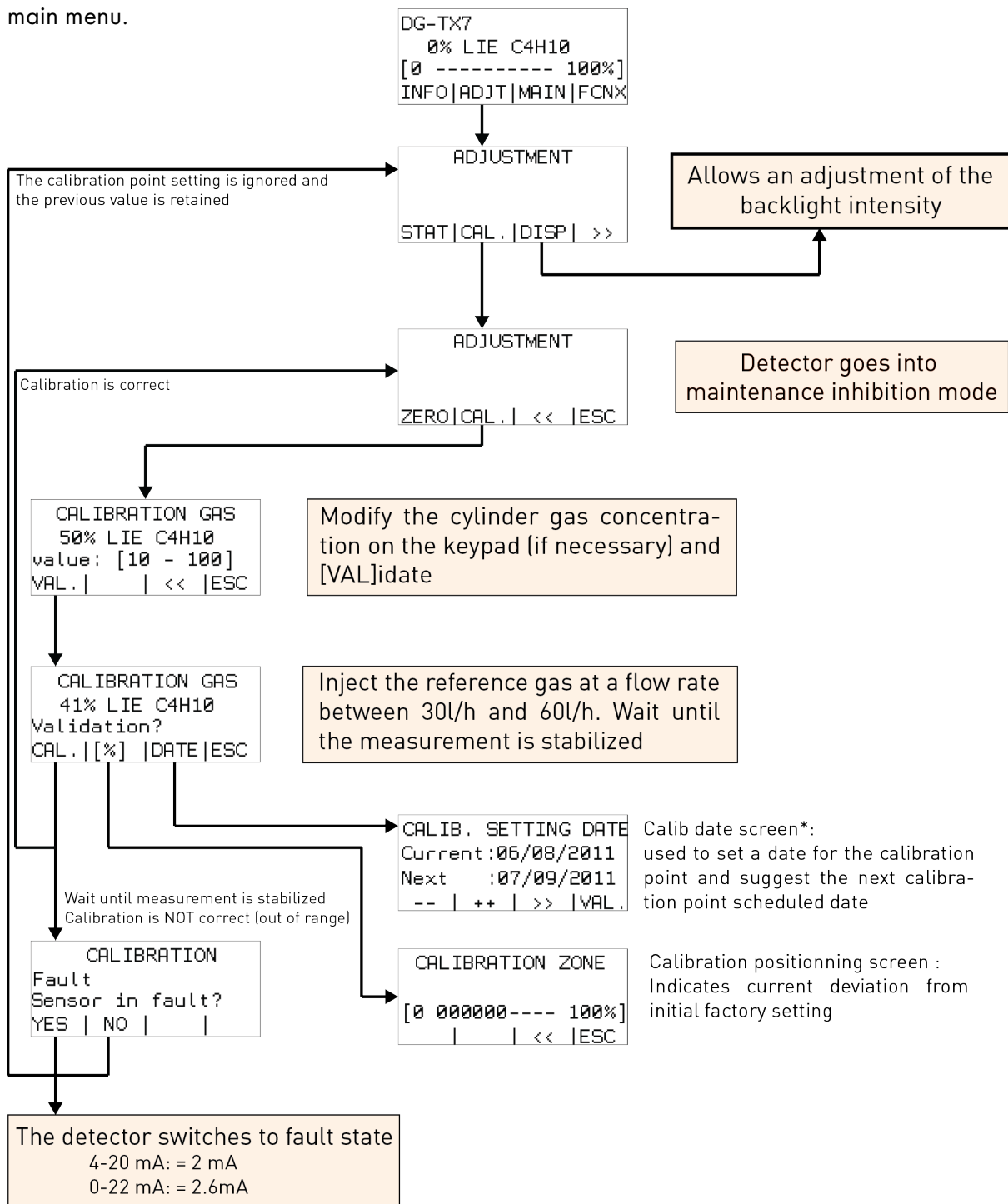

\* The device doesn't embed battery, it is then not able to keep real time. The date indication for zero or calibration points, as well as the next expected date for similar operations, are entered manually by the operator. Those data are for information only and their update is optional. mise à jour est facultative.

### 6.8.3 [DISP]LAY sub-menu

This menu gives access to the light intensity setting of the backlight and display:

- AUTO: Automatic adjustment depending on the lighting environment
- Level 0: Backlight is switched off, minimum display
- Levels 1 to 4: Intermediary levels
- Level 5: Maximum backlight intensity

### 6.8.4 [ALRM] Alarm sub-menu

The menu gives access to:

- The number of alarms levels used (0 to 4).
- The trigger's value of the alarm (levels values)
- Trigger sense of alarms (up or down)
- Memorization of alarms(yes/no)

On one hand, the alarm memorization maintains relays and alarm information on the wireless communication tool. On the other hand, the current output and the concentration displayed on the wireless communication tool are always updated with the real concentration



For a network detector, the alarm menu is unavailable.

---

### 6.8.5 [LABL] Label and [zone] sub-menu

This menu allows label and zone's modification. After selecting a label or a zone, the modification function operates in the same manner.

The numeric keys correspond to different alphanumeric characters. For each displayed page, the numeric keys have a different assignment.

Both "Label" and "Zone" fields are free text type for identification of the detector (name and position of the detector).

To edit fields, select [label] or [zone].

- Press on the corresponding numeric key to select a figure.
- Press [>>] to go to the next figure in the field.
- Press [PAGE] to go next page.

The label or zone modification must be confirmed by pressing the key VALID, otherwise the modification is not considered



For a network detector, the configuration data's (label, zone and alarms) cannot be modified.

---

## 6.8.6 [SORT] Output configuration sub-menu

### 6.8.6.1 Relays configuration

This menu gives access to the configuration of the relay operating mode and to conditions of activations.



This menu is available only with the optional relay card

---

#### State of the relays:

Each relay can be configured:

- Normally not energized
- Normally energized

#### Activation of the relays:

Each relay can be activated on one or several following conditions:

- Alarm
- Fault
- Inhibition

#### Factory setting:

- Relay 1: normally energized, activated by any fault or inhibition
- Relay 2: normally not energized, activated on alarm levels
- Relay 3: normally not energized, activated on alarm levels

Contacts are then described as below:

Detector status	Relay 1 "Fault"	Relay 2 "Alarm"	Relay 3 "Alarm"
Normal (no alarm, no fault, no inhibition and detector powered)	C1-T1 closed	C2-T2 open	C3-T3 open
	C1-R1 open	C2-R2 closed	C3-R3 closed
Alarm	C1-T1 closed	C2-T2 closed	C3-T3 closed
	C1-R1 open	C2-R2 open	C3-R3 open
Ambiguity function (TX explosimeter only)	C1-T1 open	C2-T2 closed	C3-T3 closed
	C1-R1 closed	C2-R2 open	C3-R3 open
Fault or inhibition	C1-T1 open	C2-T2 open	C3-T3 open
	C1-R1 closed	C2-R2 closed	C3-R3 closed
Maintenance Inhibition (during maintenance mode)	Depend of configuration. See chapter 6.2		
Power loss	C1-T1 open	C2-T2 open	C3-T3 open
	C1-R1 closed	C2-R2 closed	C3-R3 closed

### 6.8.6.2 Output current configuration

This menu allows you to switch the format of the output current between 4-20 mA and 0-22 mA. Factory setting: the output current is 4-20 mA

### 6.8.7 [INH]ibition submenu

Maintenance inhibition can be configured in « frozen » mode (factory setting) or « free » mode.

- In « frozen » mode, the outputs (current and relay) remain in their previous state.  
For example, if the device displays a fault (2.0 mA), it will remain in this mode during the inhibition.
- If the device is configured in « free » mode, the current output will remain at the same level than the permanent inhibition

## 6.8.8 Sous-menu [NEG] Concentration négative

The detector can display the negative concentration. There is no sense from a point of physical view but it allows to prevent a zero drift and to have a preventive maintenance before the zero drift fault.

When the negative concentration is activated, the 4-20 mA output current is 3.2 mA when the detector displays -5% of full scale.

At factory setting, the negative concentrative is deactivated.

## 6.9 Maintenance menu [MAIN]

The maintenance menu allows the user to check if the detector is in normal operation conditions

- (Test of the relay and current outputs).

### 6.9.1 [TEST] sub-menu

#### 6.9.1.1 Relay menu

This menu gives access to activation or deactivation of the relays.

The detector goes to inhibition mode. The detector will stay in inhibition mode if the user goes back through the steps to the main menu. Otherwise, the detector will return to its "current" state.

#### 6.9.1.2 The 4-20 mA screen

This menu allows the output current to be set at a chosen value. The possible output values are: 1.5 mA, 2mA, 4mA, 8mA, 12mA, 16mA, 20mA or 22mA.

During this phase, the detector goes automatically to inhibition mode. The detector will stay in inhibition mode if the user goes back through the steps to the main menu. Otherwise, the detector will return to its "current" state.

### 6.9.2 NETWORK sub-menu

This menu gives direct access to different tests for the network. For any further details, please refer to the additional network operating manual:

- SPIN sends the detectors network identification.
- LIEN switches from normal mode to logic link mode.
- SWITCH enables the switches to go on mode open/closed/open secured.

## 6.10 Ambiguity function in combustible gas detector smart sensors

In compliance with applicable standards, the ambiguity function is activated when a detected gas concentration rises above 120% LEL. The signal is locked at 21.7 mA to protect against any false measurement due to oxygen deficiency.

This function also cuts the power of the cartridge to avoid damaging the sensitive element.



The measurement signal can only be unlocked by the operator using the TLU600 remote control unit. Before that, the non-presence of inflammable gas or vapour in atmosphere must be control by the user.

Even switching the power off and back on again from the control room will not unlock the signal.

The TLU displays the following screen:

```
DG-TX7      DOUT FLT.  
> 100% LIE C4H10  
[0 0000000000 100%]  
INFO|ADJT|MAIN|FCNX
```

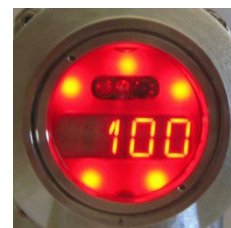

To clear the ambiguity, follow the instruction below with the TLU600:

INFO / STAT / ALRM / ACK. (YES)

```
ALARM ACKNOLEDGE  
+ Overshoot ack.  
Confirm?  
YES | >> | <<< | ESC
```



The device then goes in warming-up mode (refer to §6.3) for 90s. The detector is in inhibition mode. The current output and the default relay (if factory setting) are consequently activated.

A warming-up timer starts to countdown from 90 sec.

```
DG-TX7      INH.  
Warming-Up : 87s  
[0 00000----- 100%]  
INFO|ADJT|MAIN|FCNX
```

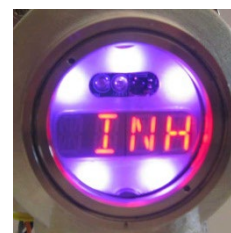

Then, the inhibition is released.

## 6.11 Magnets operation

The digital display gives access to different menus.

To enter in these menus, the wand has to put in place on the stickers "PG1" or "PG2". The user must maintain the wand on the magnets with time longer or shorter depending on the desired function. The following symbols that appear on the display give indication of time:

- -: brief contact
- <: short contact corresponding to 1 s
- <<: long contact corresponding to 2s
- <<<: very long contact corresponding to 5s

For example:

To modify the calibration gas value, put the wand on the "PG2" sticker during 5 seconds until the symbol <<< appears. The display indicates "VIEW CONFIG". Put in place the wand on PG2 until "CALIB GAS" appears. Put the wand on PG1 during 1 second to enter in the menu.

Depending on gas concentration injected, decrease the value with PG1 or increase it with PG2.

In his normal state, the detector displays every 30 minutes the gas unit, the gas, the label and the concentration. When the detector is in fault, the message "DEF" replaces the concentration. When the detector is in alarm, la concentration stays on the display.

Some function requires a code that is active for 10 minutes. This maintenance code can be change by the user ("0" means that the code is inactive, any value other than zero involves the code request to access to the desired function).

These codes are saved in case of shutdown or reset.



The menu about the relays is available only If there is no optional card. Only the relay state (energized / not energized) can be modified by the magnetic wand.

If you have a network card in the detector, the menu Alarm is unavailable.

---

# MULTIPLO AND MULTITOX DETECTORS

## OPERATING MANUAL

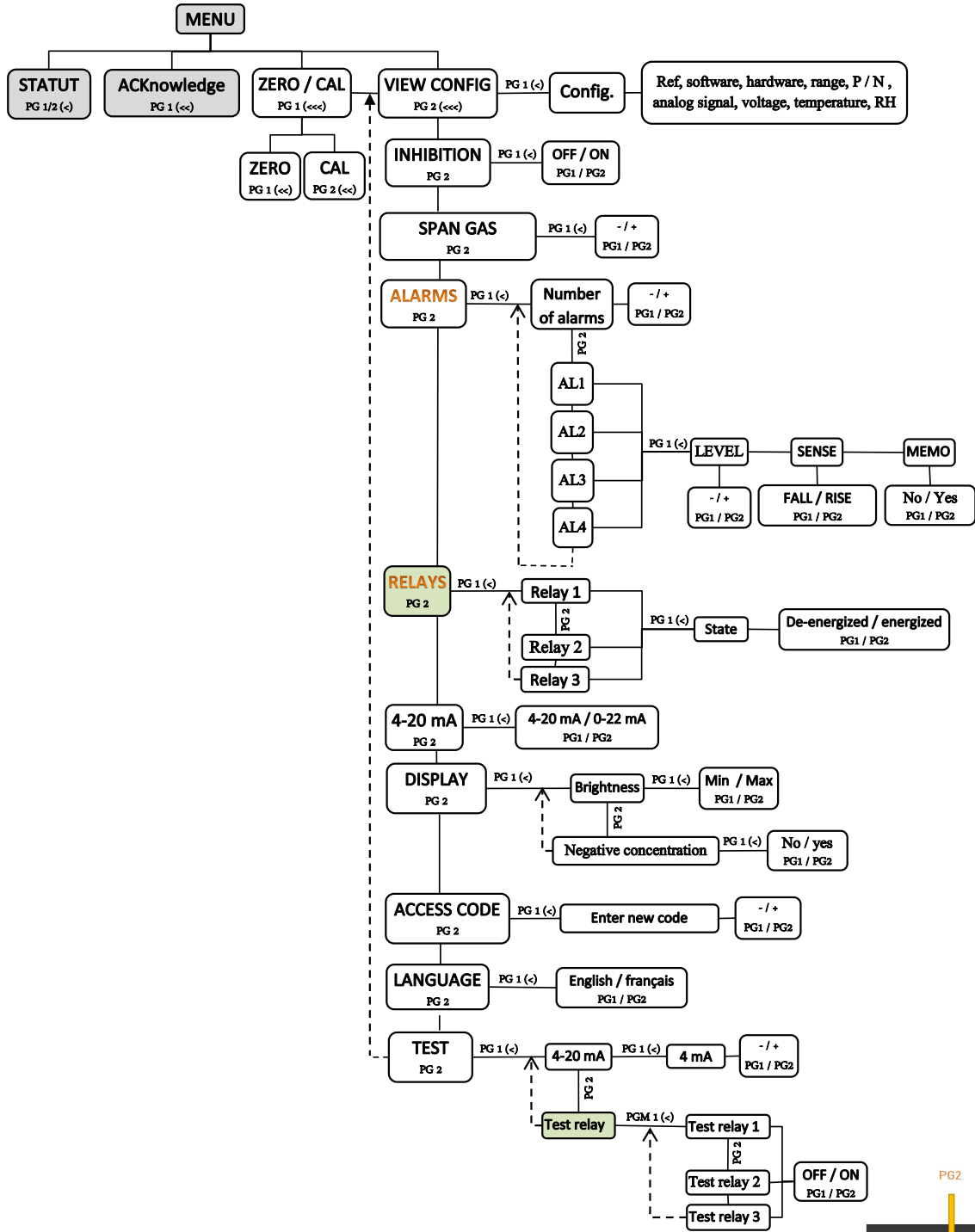

- AL Menus not available with Syntel card
- Menus available with relay card
- Menus available without access code

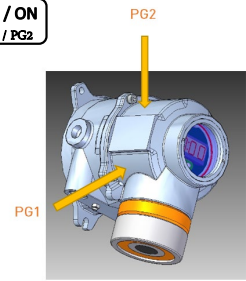

## 7 Maintenance



The interventions described in this chapter must be performed by competent and qualified staff. Device performances may be affected if the present instructions are not respected.

Cartridge unplug or device opening imperatively require power to be OFF

---



Zero adjustment does not affect the sensitivity of the detector and vice versa.

---

### 7.1 Power off / opening of housing



All the power supply wires must be cut to put unpowered the detector

---

### 7.2 Periodic maintenance

The frequencies of calibration control are provided for information purposes only. The frequency depends on the operating conditions, the experience and safety requirements.

However, regarding the functional safety certification of the device (SIL), an annual check is a minimum required.

#### 7.2.1 Preventive maintenance

A gas test is recommended every six months. Run a calibration if necessary. A zero-point calibration with clean air has to be done first.



We recommend using gas mixture with the target gas at 50% of the measuring range. The complement of the mixture should be Air for DG-TX7-X and air or Nitrogen for DG-TT7-K.

Periodicity of the maintenance should be adjusted (reduced) if the device is exposed to the conditions defined by the IP rating.

---

If the detector enters in ambiguity mode, a test of the zero point and a gas test are recommended. We recommend cleaning the communication head window at the same time.

For any other operation, please contact your supplier or our technical services.

## 7.2.2 Corrective maintenance

If the detection unit or the PLC signals a detector's fault, the detector must be tested directly with the wireless communication tool to determine the type of fault.

If the detector is configured in 0-22 mA output, it is possible to have a pre-diagnostic of the fault.

## 7.2.3 Loop test

In order to test the complete loop, several options can be used:

- Make a complete loop test by exposing the detector to gas
- Make a loop test in two parts by:
  - Manually switching the detector outputs thanks to the TLU remote as described in the section §6.9.1 in order to test the current and relays outputs
  - Exposing the detector to gas and watch the concentration on the display

Make sure that the elements connected to the detector (control system, fire panel or other extinguishing equipment) are under control, in order to avoid nuisance alarms.

Or any other operation, please contact your distributor or our technical services.

## 7.3 List of main faults

In addition of the current loop faults, other information are available from the wireless communication tool TLU600 (refer to § 6.6). If the detector does not work properly, the following table can help you to determine the causes and effects of different possible troubles.

FAULTS	CAUSES	SOLUTIONS
Backlight display switched off	Power supply failure	Check the power supply (18 and 35 V <sub>DC</sub> ) at the detection unit or the PLC output
	Continuity issue	Check line continuity
No 4-20 mA / 0-22 mA signal 3-wire cabling	Power supply failure	Check the power supply (18 and 35 V <sub>DC</sub> ) at the detection unit or the PLC output
	Continuity issue	Check line continuity
	No shunt between V+ and L+	Place the shunt
No 4-20 mA / 0-22 mA signal 4-wire cabling	Power supply fault	Check the loop with an ammeter.
ZERO_FAULT (Zero point fault)	Zero-point resetting impossible	Fault memorized, even on a power supply shut down. To acknowledge this fault, make a full calibration (in general, the sensor needs to be replaced).
DRIFT_FAULT (Zero-point drift)	Sensor drift: the measure is below -10%	Non-memorized fault. Automatic acknowledgement when the measure goes back above -10%. Resetting the zero point is necessary.
CALIB_FAULT (Calibration fault)	Calibration resetting impossible	Memorized fault, even on a power supply shut down. To acknowledge this fault, make a full calibration (in general, the sensor needs to be replaced).

FAULTS	CAUSES	SOLUTIONS
SELFTEST_FAULT SENSOR_FAULT (Fault material)	Material trouble (electronic part failure) on the sensor or on the electronic board of the detector  This fault is triggered if there is no sensor in the detector.	Non-memorized fault. Automatic acknowledgement when the detector is back to normal operation conditions.  An electronic failure of the detector hardly happens. Replacing the cartridge will solve the problem most of the time.
TEMPERATURE_FAULT (Temperature fault)	Temperature sensor is out of order or disconnected. The temperature sensor is in the cartridge.	Non-memorized fault. Automatic acknowledgement when the detector is back to normal operation conditions.  Replace the cartridge.
No wireless communication tool connection	Detector unpowered  Dialogue problem	Check that the display is lighted  Check the wireless communication tool by using it on another detector.
Detector fault (Material fault)	Electronic fault	Replace the detector

## 7.4 Replacing the cartridge

Follow the instruction in § 4.4.

## 7.5 Replacing the complete detector

If the operator needs to replace the complete detector, the easiest way is to take off the main housing from the base of the detector (for more details, refer to § 4.2.1).

As the base of the detector remains in place, cable glands do not need to be dismantled. If the detector is not replaced immediately, the “open” base must be protected against humidity, dust and shocks



No intervention should be carried out when the detector is powered.

## 8 Certification

### 8.1 Functional safety

DG-TX7-X is SIL2 certified when the safety function is the current output et SIL1 when the safety function is the relays output.

DG-TX7-K is SIL2 certified when the safety function is the current or the relays output.

In order to maintain the SIL levels, the current output (or relays) must be checked every 12 months.



This verification is described in the section § 7.2.3 - Loop test.



Important: The SIL level indicated applies for a safety function using either the current outpur or the relay output.<sup>6</sup>

### 8.2 ATEX / IECEx marking

The detector identification label is located on the main housing, according to ATEX directives ATEX 2014/34/UE

- Constructor: TELEDYNE OLDHAM SIMTRONICS
- Model: DG-TX7...  
DG-TT7...
- Serial Number: S/N: xxxxxxxxxx (xxxxaamm)
- Type of certification: CE0080  II2G / Ex db IIC T6 Gb  
CE0080  II2G / Ex db IIB T6 Gb  
(2 mm > Paint thickness > 200µm)  
version : DG-T\*7-\*\*\*\*-\*\*\*-\*\*-L\*-\*-\*)  
-40°C < Ta < + 65°C  
-20°C < Ta < + 60°C (external probe version)
- Certificate number: ATEX: LCIE 11 ATEX 3081X  
IECEX: LCI 11.0060X

<sup>6</sup> If the relay output is used as a safety function then the relays must be in factory setting to maintain the SIL level, namely:

- Relay 1: normally energized, activated by any fault or inhibition
- Relay 2 and 3: normally not energized, activated on alarm levels

- External probe SX202 LCIE 03 ATEX 6258 /  $-20^{\circ}\text{C} < T_a < 60^{\circ}\text{C}$
- Standard product reference EN 60079-29-1 : INERIS 11ATEX0033 (DG-TX7-X)  
(External probe version excluded)
- Warnings: Warning - Do not open when energized. After de-energizing, delay 2 minutes before opening.
- Ingress rate: IP66 \*
- Maximum power supply voltage 35 Vdc
- Maximum consumption 5 W

\* IP rating does not mean that the equipment will detect the gas during or after exposure to the defined conditions.

It is also recommended to use the device with the following accessories: AS056-250, AS019, AS015.



TELEDYNE OLDHAM SIMTRONICS does not allow any repairs of the flameproof joints and shall not be responsible for any modification of material.

---







### 8.3 Specific Conditions of use

User shall install Ex certified cable gland that do not degrade protection mode.

Only the screw of property class A4-70 (yield stress  $\geq 450\text{MPa}$ ) must be used as a special fastener.

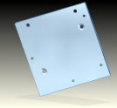





## 9 Accessories and spare parts

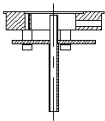
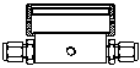
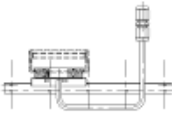
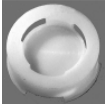

### 9.1 Accessories

Accessories	Designation	Description	Part Number
	IRDA Remote control unit TLU 600	Required for adjustments and maintenance	TLU 600
	Remote control unit HART	Available for adjustments and maintenance	TLH 700
	Adapting Plate (BT05-BT606-BT10)	Used to adapt old detector (BT05-BT606) attachments to fit new generation detectors (BT10: DG, DGi)	AS049
	Calibration cup	Fits all cartridges	AS005 ①⑤
	Tag plate	For on-site identification of detectors	AS215
	Calibration kit	The kit comprises:  One air cylinder and one pressurized cylinder containing a mixture of air and a gas of titrated concentration,  A 30 l/H flow rate pressure reducing and regulating valve,  A 3-meter pipe.  The calibrating cup is not included in the calibration kit except for H <sub>2</sub> DM-TX6-X	CAL-K##-.... ①
	Filter support	For use in certain situations with molecular filters in order to block out interfering gases.	AS015 ②

# MULTIPLO AND MULTITOX DETECTORS

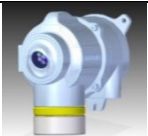
OPERATING MANUAL

Accessories	Designation	Description	Part Number
	Remote calibration connection	Accessory enabling a gas supply tube to be attached near the cartridge.	AS016 ①
	Stainless steel sample flow with 2 ways	For use with gas circuit systems.	AS011-2X ①
	Duct mounting	A series of accessories for installing detectors on different types of ducts	AS02x ①
	Water, sand and dust protection	Adaptation to all cartridges, the assembly is directly in front of cartridge thanks to the nut of maintain (black on version -A).	AS019 ③
	Suspension cable enclosure/body	Enables to connect the enclosure with the body during the maintenance operations	AS052
	Tube mounting adapter	Enables DM-T#6, DMi-TT6, DG-T#7, DGi-TT7 et GD10P lines to be mounted on a 2 inch to 2.5 inch diameter tube	AS053
	Display protection	Enables to protect the infrared communication zone in order to better the dialog with the TLU in full sun	AS047 ④
	Multi-position socket (wall or tube mounting)	Enables to fix the device from the top. Can be orientated in all directions.	AS048
	Weather protection (wall or tube mounting)	Dedicated to protect apparatus from sun / rain / snow.	AS056-250 ④
	IRDA cap	Replaces the display and its backlight by a fixed IRDA communication head	Factory setting type 00D : DG-**-7-****- ***-**-00D-**- *_*

Accessories	Designation	Description	Part Number
	SX202 / MTHX-S calibration cup	screwed on the sensor (external probe only)	AS205 ①
	Magnetic wand	Used for setting and maintenance	AS055

① Detector sensitivity is not modified, response time depend on the flow rate used for injection. A flow rate between 0.5 L/min and 1 L/min should comply with “standard” response time.

When using an AS005 with a DG-TX7-X, it is recommended to inject gas through the side of the calibration cup.

② Detector sensitivity is not modified; response time can increase depending on the molecular filter used.

③ Detector sensitivity is not modified, response time (T90) (natural diffusion condition) is increased by 50%.

④ Detector sensitivity and response time are not modified.

⑤ This accessory is included into the EN60079-29-1 Performance Certificate.



Wipe non-conductive parts (plastic) that can use in ATEX area with a damp cloth (risk of electrostatic charges)

## 9.2 Spare parts

- O-ring spare parts
- For the base (All models) - O-ring kit BT10
- Lubricant for explosion proof seal and thread: MOLYKOTE Brand, reference P40.
- Combustible gas detector cartridges : DM-SX6-SADG-XX0-X0 (gas to specify)
- Catharometer cartridges : DM-SX6-SADG-KX0-X0 (gas and range to specify)

### Storage life of accessories and spare parts :

Ref	Temperature	Humidity	Pressure	Time
TLU600	-20°C to +45°C	95% HR (non condensable)	1013 hPa +/- 20%	2 ans in « clean » atmosphere
TLH700	-20°C to +60°C	95% HR (non condensable)	1013 hPa +/- 20%	2 ans in « clean » atmosphere
Mechanical Products (*)	-20°C to +40°C	95% HR (non condensable)	1013 hPa +/- 20%	2 ans in « clean » atmosphere
CAL-K##-...		Same as detector		
O-ring		Same as detector		
O-ring kit BT10		Same as detector		
MOLYKOTE Brand, P40		Same as detector		60 months
Combustible cartridge		Same as detector		
Catharometer cartridge		Same as detector		

\* Products called « mechanical » in the previous table are :

AS045, AS005, AS215, AS015, AS016, AS011-2X, AS02x, AS019, AS052, AS053, AS047, AS048, AS056-250, AS205, AS055.

## 9.3 Gas table codes & range table codes

According to the new references: DG-TX7-F1F2-X□□-□□-□□□-□-□-□

F1	Formula	Gas name	Comment	F2	Range
01	AsH <sub>3</sub>	Arsine		00	Pas
02	C <sub>2</sub> H <sub>2</sub>	Acetylene		AA	1 ppm
03	C <sub>2</sub> H <sub>4</sub>	Ethylene		AB	2 ppm
04	C <sub>2</sub> H <sub>4</sub> O	Ethylene oxide		AC	5 ppm
05	C <sub>2</sub> H <sub>6</sub> O	Ethanol		AD	10 ppm
06	C <sub>2</sub> H <sub>6</sub> O	Dimethylene		AE	20 ppm
07	C <sub>3</sub> H <sub>6</sub>	Propene		AF	50 ppm
08	C <sub>3</sub> H <sub>6</sub> O	Acetone		AG	100 ppm
09	C <sub>3</sub> H <sub>8</sub>	Propane		AH	200 ppm
10	i-C <sub>4</sub> H <sub>10</sub>	i-Butane		AJ	500 ppm
11	C <sub>5</sub> H <sub>12</sub>	Pentane		AK	1000 ppm

# MULTIXPLO AND MULTITOX DETECTORS

OPERATING MANUAL

F1	Formula	Gas name	Comment	F2	Range
12	C <sub>6</sub> H <sub>14</sub>	Hexane		AL	2000 ppm
13	C <sub>6</sub> H <sub>6</sub>	Benzene		AM	5000 ppm
14	C <sub>7</sub> H <sub>8</sub>	Toluene		AN	10000 ppm
15	C <sub>8</sub> H <sub>8</sub>	Styrene		AP	3000 ppm
16	CH <sub>2</sub> Cl <sub>2</sub>	Dichloromethane		AQ	25 ppm
17	CH <sub>4</sub>	Methane		BA	1 %Vol
18	CH <sub>4</sub>	Methane	(Biogas)	BB	2 %Vol
19	CH <sub>4</sub> O	Methanol		BC	5 %Vol
20	Cl <sub>2</sub>	Chlorine		BD	10 %Vol
21	CO	Carbon monoxide	(H2S comp)	BE	20 %Vol
22	CO	Carbon monoxide		BF	50 %Vol
23	CO <sub>2</sub>	Carbon dioxide		BG	100 %Vol
24	CO <sub>2</sub>	Carbon dioxide	(CH4 immune)	BH	3 %Vol
25	COCl <sub>2</sub>	Phosgene		BJ	25 %Vol
26	X	All gases		BK	4 %Vol
27	CTFE	CTFE		BL	21 %Vol
28	CVM	Vinylchloride		BM	24 %Vol
29	F <sub>2</sub>	Fluorine		BN	17 %Vol
30	H <sub>2</sub>	Hydrogen		BZ	Other % vol
31	H <sub>2</sub> S	Hydrogen sulphide		DE	20 %LIE (1)
32	HCl	Hydrogen chloride		DF	50 %LIE (1)
33	HCN	Hydrogen cyanide		DG	100 %LIE (1)
34	He	Helium		DH	30 %LIE (1)
35	HF	Hydrogen fluoride		DJ	15 %LIE (1)
36	MCPE	MCPE		DP	125 %LIE (1)
37	N <sub>2</sub>	Nitrogen		EE	20 %LIE (2)
38	n-C <sub>4</sub> H <sub>10</sub>	n-Butane		EF	50 %LIE (2)
39	NH <sub>3</sub>	Ammonia		EG	100 %LIE (2)
40	NO	Nitric oxide		GC	5 LELm
41	NO <sub>2</sub>	Nitrogen dioxide		KA	1 ppm*m
42	O <sub>2</sub>	Oxygen		JB	2 ppm*m
43	O <sub>3</sub>	Ozone		KC	5 ppm*m
44	PFBA	PFBA		KD	10 ppm*m
45	R22	Chlorodifluoromethane		KE	20 ppm*m
46	R23	Trifluoromethane		KF	50 ppm*m
47	SO <sub>2</sub>	Sulphur dioxide		KG	100 ppm*m
48	C <sub>5</sub> H <sub>10</sub>	Cyclopentane		KH	200 ppm*m
49	VC <sub>2</sub>	VC2		KJ	500 ppm*m
50	D40	White Spirit		KK	1000 ppm*m
51	/	Gasoil		KL	2000 ppm*m
52	/	Super 95		KM	5000 ppm*m
53	/	Super 98		KN	10000 ppm*m
54	/	LPG		LH	200 ppm*m/100 %LEL*m

# MULTIXPLO AND MULTITOX DETECTORS

## OPERATING MANUAL

F1	Formula	Gas name	Comment	F2	Range
F1	Formula	Gas name	Comment	F2	Range
55	C <sub>2</sub> H <sub>5</sub> Cl	Ethyl chloride		LJ	500 ppm*m/100 %LEL*m
56	C <sub>2</sub> H <sub>6</sub>	Ethane		LK	1000 ppm*m/100 %LEL*m
57	C <sub>3</sub> H <sub>3</sub> N	Acrylonitrile/Vinyl cyanide		LM	5000 ppm*m /100 %LEL*m
58	C <sub>3</sub> H <sub>6</sub> Cl <sub>2</sub>	Dichloroethane		ZZ	Other
59	C <sub>3</sub> H <sub>6</sub> O	Propylene oxide			
60	C <sub>3</sub> H <sub>8</sub> O	Isopropyl alcohol			
61	C <sub>3</sub> H <sub>8</sub> O	Propyl alcohol			
62	C <sub>4</sub> H <sub>10</sub> O	Butanol			
63	C <sub>4</sub> H <sub>6</sub>	Butadiene			
64	C <sub>4</sub> H <sub>8</sub>	Butene			
65	C <sub>4</sub> H <sub>8</sub> O	Butanal			
66	C <sub>4</sub> H <sub>8</sub> O	Methyl-ethyl-ketone(MEK)			
67	C <sub>4</sub> H <sub>9</sub> O <sub>2</sub>	Ethyl acetate			
68	C <sub>5</sub> H <sub>10</sub> O	Methyl-isopropyl-ketone			
69	C <sub>5</sub> H <sub>10</sub> O <sub>2</sub>	Propyl acetate			
70	C <sub>5</sub> H <sub>12</sub> O	Isopentanol			
71	C <sub>5</sub> H <sub>8</sub>	Isoprene			
72	C <sub>6</sub> H <sub>10</sub>	D-limonene			
73	C <sub>6</sub> H <sub>12</sub>	Cyclohexane			
74	C <sub>6</sub> H <sub>12</sub>	Hexene-1			
75	C <sub>6</sub> H <sub>12</sub> O <sub>2</sub>	Butyl acetate			
76	C <sub>7</sub> H <sub>16</sub>	Heptane			
77	C <sub>6</sub> H <sub>4</sub> (CH <sub>3</sub> ) <sub>2</sub>	Xylene			
78	C <sub>7</sub> H <sub>12</sub> O <sub>2</sub>	N-butyacrylate			
79	C <sub>2</sub> H <sub>4</sub>	Ethylene	(special : low interf.C2H6)		
80	C <sub>3</sub> H <sub>8</sub>	Propane	(special: low interf. CH4)		
81	CH <sub>4</sub>	Methane	(special : low interf.C3H8)		
82	C <sub>8</sub> H <sub>18</sub>	Octane			
83	CF <sub>3</sub> -CFH <sub>2</sub>	R134a			
84	/	Kerosene			
85	C <sub>2</sub> Cl <sub>4</sub>	Tetrachloroethene			
86	C <sub>2</sub> H <sub>4</sub>	Ethylene	Special customer (EG)		
87	HC lourd	F1850	Special customer		
88	(CH <sub>3</sub> ) <sub>3</sub> COCH <sub>3</sub>	MTBE			
89	H <sub>2</sub> S + CH <sub>4</sub>	Hydrogen sulfide + Methane			
SA	Xs	Special combustible gas	App SA		
CS	H <sub>2</sub>	Hydrogen in Argon	Complement Argon		
CU	H <sub>2</sub>	Hydrogen in Azote	Complement Azote		

Regarding reference F2 = DG (100% LEL), the following table defines what TELEDYNE OLDHAM SIMTRONICS uses of correspondence between %vol and 100% LEL.

For most of the gases, we use the INRS 2015 data, except for some gases for which we are more conservative (except ammonia and heptane).

F1	Nom produit	Name of compound	Formule Formula	% vol équivalent à 100 % LIE / LEL
63DG	1,3-butadiène	1,3-Butadiene	C <sub>4</sub> H <sub>6</sub>	1.4
64DG	1-Butène	1-Butene	C <sub>4</sub> H <sub>8</sub>	1.6
08DG	Acétone	Acetone	C <sub>3</sub> H <sub>6</sub> O	2.6
02DG	Acétylène	Acetylene	C <sub>2</sub> H <sub>2</sub>	2.2
39DG	Ammoniac	Ammonia	NH <sub>3</sub>	16.0
13DG	Benzène	Benzene	C <sub>6</sub> H <sub>6</sub>	1.2
38DG	n-Butane	n-Butane	C <sub>4</sub> H <sub>10</sub>	1.8
38EG	n-Butane (LIE 2)	n-Butane	C <sub>4</sub> H <sub>10</sub>	1.4
28DG	Chlorure de vinyle	Vinyl chloride	C <sub>2</sub> H <sub>3</sub> Cl	3.6
73DG	Cyclohexane	Cyclohexane	C <sub>6</sub> H <sub>12</sub>	1.3
06DG	Diméthyle éther	Dimethyl ether	C <sub>2</sub> H <sub>6</sub> O	2.7
56DG	Ethane	Ethane	C <sub>2</sub> H <sub>6</sub>	3.0
56EG	Ethane (LIE 2)	Ethane	C <sub>2</sub> H <sub>6</sub>	2.4
05DG	Ethanol	Ethanol	C <sub>2</sub> H <sub>5</sub> OH	3.3
03DG	Ethylène	Ethylene	C <sub>2</sub> H <sub>4</sub>	2.7
76DG	Heptane	Heptane	C <sub>7</sub> H <sub>16</sub>	1.1
30DG	Hydrogène	Hydrogen	H <sub>2</sub>	4.0
10DG	Isobutane	Iso-butane	i-C <sub>4</sub> H <sub>10</sub>	1.8
60DG	Isopropanol	2-Propanol	C <sub>3</sub> H <sub>8</sub> O	2.0
17DG	Méthane	Methane	CH <sub>4</sub>	5.0
17EG	Méthane (LIE 2)	Methane	CH <sub>4</sub>	4.4
19DG	Méthanol	Methanol	CH <sub>3</sub> OH	5.5
12DG	n-Hexane	n-Hexane	C <sub>6</sub> H <sub>14</sub>	1.1
12EG	n-Hexane (LIE 2)	n-Hexane	C <sub>6</sub> H <sub>14</sub>	1.0
11DG	Pentane	Pentane	C <sub>5</sub> H <sub>12</sub>	1.4
09DG	Propane	Propane	C <sub>3</sub> H <sub>8</sub>	2.2
09EG	Propane (LIE 2)	Propane	C <sub>3</sub> H <sub>8</sub>	1.7
07DG	Propylène / propène	Propylene / propene	C <sub>3</sub> H <sub>6</sub>	2.0
15DG	Styrène	Styrene	C <sub>8</sub> H <sub>8</sub>	1.1
14DG	Toluène	Toluene	C <sub>7</sub> H <sub>8</sub>	1.2
77DG	Xylène	Xylene	C <sub>6</sub> H <sub>4</sub> (CH <sub>3</sub> ) <sub>2</sub>	1.0

# MULTIXPLO AND MULTITOX DETECTORS

OPERATING MANUAL



# MULTIXPLO AND MULTITOX DETECTORS

OPERATING MANUAL



**TELEDYNE**  
**OLDHAM SIMTRONICS**  
Everywhereyoulook™



**AMERICAS**

14880 Skinner Rd  
CYPRESS  
TX 77429,  
USA  
Tel.: +1-713-559-9200

**EMEA**

Rue Orfila  
Z.I. Est – CS 20417  
62027 ARRAS Cedex,  
FRANCE  
Tel.: +33 (0)3 21 60 80 80

**ASIA PACIFIC**

Room 04, 9th Floor, 275  
Ruiping Road, Xuhui District,  
Shanghai  
CHINA  
TGFD\_APAC@Teledyne.com

[www.teledynegasandflamedetection.com](http://www.teledynegasandflamedetection.com)



© 2024 TELEDYNE OLDHAM SIMTRONICS. All right reserved.  
NOSP17665 Revision 04 / june 2024