



**TELEDYNE**  
**OLDHAM SIMTRONICS**  
Everywhereyoulook™

# OPERATING MANUAL

## MULTITOX DETECTOR



MultiToxDGi-TT7-E

DGi-TT7-O

DG-TT7-S

(with Magnetic interface)

# MULTITOX DETECTOR

OPERATING MANUAL

User manuals in other languages are available on  
Website <https://teledynegasandflamedetection.com>



Copyright © December 2025 by TELEDYNE OLDHAM SIMTRONICS S.A.S.

All rights reserved. No reproduction of all or part of this document, in any form, is permitted without the written consent of TELEDYNE OLDHAM SIMTRONICS S.A.S.

All of the information that is provided in this document is accurate to the best of our knowledge.

As a result of continuous research and development, the specifications of this product may be changed without prior notice.

TELEDYNE OLDHAM SIMTRONICS S.A.S.

Rue Orfila

Z.I. Est – CS 20417

62027 ARRAS Cedex

## Limitation of Liability

The Company TELEDYNE OLDHAM SIMTRONICS S.A.S., hereinafter referred to as "TELEDYNE OLDHAM SIMTRONICS" throughout this document, shall not be held responsible for any damage to the equipment or for any physical injury or death resulting in whole or in part from the inappropriate use or installation of the equipment, non-compliance with any and all instructions, warnings, standards and/or regulations in force.

No business, person or legal entity may assume responsibility on behalf of TELEDYNE OLDHAM SIMTRONICS, even though they may be involved in the sale of TELEDYNE OLDHAM SIMTRONICS products.

TELEDYNE OLDHAM SIMTRONICS shall not be responsible for any direct or indirect damage, or any direct or indirect consequence, resulting from the sale and use of any of its products **UNLESS SUCH PRODUCTS HAVE BEEN SELECTED BY TELEDYNE OLDHAM SIMTRONICS ACCORDING TO THE APPLICATION.**

## Ownership clauses

The drawings, specifications, and information herein contain confidential information that is the property of TELEDYNE OLDHAM SIMTRONICS.

This information shall not, either in whole or in part, by physical, electronic, or any other means whatsoever, be reproduced, copied, divulged, translated, or used as the basis for the manufacture or sale of TELEDYNE OLDHAM SIMTRONICS equipment, or for any other reason **without the prior consent of TELEDYNE OLDHAM SIMTRONICS.**

## Warning

This is not a contractual document. In the best interest of its customers and with the aim of improving performance, TELEDYNE OLDHAM SIMTRONICS reserves the right to alter the technical features of its equipment without prior notice.

**READ THESE INSTRUCTIONS CAREFULLY BEFORE THE FIRST USAGE:** these instructions should be read by all persons who have or will have responsibility for the use, maintenance, or repair of the instrument.

This instrument shall only be deemed to be in conformance with the published performance if used, maintained, and repaired in accordance with the instructions of TELEDYNE OLDHAM SIMTRONICS by TELEDYNE OLDHAM SIMTRONICS personnel or by personnel authorized by TELEDYNE OLDHAM SIMTRONICS.

## Important Information

The modification of the material and the use of parts of an unspecified origin shall entail the cancellation of any form of warranty.

The use of the unit has been projected for the applications specified in the technical characteristics. Exceeding the indicated values cannot in any case be authorized.

TELEDYNE OLDHAM SIMTRONICS recommends regular testing of fixed gas detection installations (read Chapter 7.2).

## Warranty

Under normal conditions of use and on return to the factory, MultiTox detectors carry a 1-year warranty excluding accessories such as tilt mount, weather protection, etc.

## Destruction of the equipment

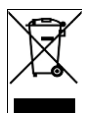

**European Union (and EEA) only.** This symbol indicates that, in conformity with directive DEEE (2002/96/CE) and according to local regulations, this product may not be discarded together with household waste.

It must be disposed of in a collection area that is set aside for this purpose, for example at a site that is officially designated for the recycling of electrical and electronic equipment (EEE) or a point of exchange for authorized products in the event of the acquisition of a new product of the same type as before.

# Table of Contents

<b>1</b>	<b>Product description .....</b>	<b>1</b>
1.1	Application .....	1
1.2	DGi-TT7-E .....	2
1.3	DGi-TT7-O .....	2
1.4	DG-TT7-S .....	2
1.5	Heating (DGi version only) .....	3
1.6	Technical specifications .....	3
1.7	Detection cartridge .....	4
1.8	Communication Interface .....	4
1.9	Product Code .....	6
<b>2</b>	<b>Technical features.....</b>	<b>9</b>
<b>3</b>	<b>Scales and technical data .....</b>	<b>13</b>
<b>4</b>	<b>Installation .....</b>	<b>15</b>
4.1	Positioning .....	15
4.2	Assembly .....	15
4.3	Electric Connection .....	18
4.4	Detection cartridge.....	25
<b>5</b>	<b>Commissioning .....</b>	<b>27</b>
5.1	Visual inspection .....	27
5.2	Power-up.....	27
5.3	Operational tests .....	27
<b>6</b>	<b>Operation.....</b>	<b>29</b>
6.1	Environmental conditions .....	29
6.2	Inhibition .....	30
6.3	Signal current loop .....	31
6.4	Alarm indication .....	32
6.5	Display indication .....	32
6.6	Wireless communication tool TLU600.....	34

# MULTITOX DETECTOR

## OPERATING MANUAL

6.7	Information menu [INFO] .....	37
6.8	Adjustment menu [ADJT] .....	38
6.9	Maintenance menu [MAIN] .....	46
6.10	Magnets operation .....	47
<b>7</b>	<b>Maintenance .....</b>	<b>49</b>
7.1	Open enclosure before Power off.....	49
7.2	Periodic maintenance.....	49
7.3	List of main faults .....	51
7.4	Replacing the cartridge .....	52
7.5	Replacing the complete detector.....	52
<b>8</b>	<b>Certifications and standards .....</b>	<b>53</b>
8.1	Functional Safety .....	53
8.2	ATEX / IECEx Marking .....	53
8.3	Specific Conditions of use .....	55
<b>9</b>	<b>ACCESSORIES AND SPARE PARTS .....</b>	<b>57</b>
9.1	Accessories.....	57
9.2	Spare parts.....	59
9.3	Gas table codes & range table codes.....	60

# 1 Product description

The DGi-TT7-E is designed to monitor poisoning risk induced by the presence of toxic gases or vapours (hydrogen sulphide, carbon monoxide, ammonia...).

The DGi-TT7-O is designed to monitor the oxygen concentration in %vol either for inerting (scales 1 or 5%vol.) or in breathable atmosphere control (Scale 0-25%vol).

Both versions are equipped with electrochemical cells.

The DGi-TT7-S is designed to monitor poisoning risk induced by the presence of toxic gases or vapours, such as hydrogen sulphide. This version is equipped with semiconductor cells.

Detectors can be connected to a large range of controllers or PLC.

These detectors may be configured using the portable communication terminal (TLU600) in ATEX areas, providing flexibility to the user.

These detectors can be configured also using the magnetic wand or the Hart portable terminal TLH710 (in option).

MultiTox are also available for use in an addressable network system with distributed intelligence SYNTEL. For more information, please refer to the Syntel module interface operating manual.

## 1.1 Application

The DGi-TT7 and DG-TT7 are suitable for indoor or outdoor use and offer a fast response time. Typical applications include:

- Storage of toxic products
- Monitoring of processes with toxic products
- Oxygen detection in inert atmosphere (DG-TT7-O)
- Chemical and petrochemical plants
- Drilling platforms
- Refineries



### 1.2 DGi-TT7-E

The DGi-TT7-E is a MultiTox detector based on a transducer with electrochemical cell, which requires oxygen to function properly.

The measuring principle is based on a redox reaction.

In the event of a long period without oxygen, the measurement will not be representative of gases or vapours concentration.

The characteristics of the device can also be altered by exposures to high concentrations or by extended periods in hot and dry atmosphere.

### 1.3 DGi-TT7-O

The DGi-TT7-O is a MultiTox detector based on a transducer with electrochemical cell. The measurement range is expressed in %vol O<sub>2</sub>.

The measuring principle is based on one of the principle of the « oxygen cell ».

There are two types of cell:

- Type M corresponding to device DGi-TT6-42BJ-EA\*-M\*
- Type Y corresponding to device DGi-TT6-42BJ-EA\*-Y\* (specific lifetime)

Characteristics of the device can also be altered by exposures to extended periods in hot and dry atmosphere.

### 1.4 DG-TT7-S

Le DG-TT7-S is a MultiTox detector based on a transducer with semi-conductor cells, which requires oxygen to function properly. It is used mainly for hydrogen sulphide detection in difficult industrial environment.

The measuring principle is based on oxidation and adsorbing reactions on films surface of heated semi-conductor.

This sensor uses a sensitive element that only requires half-yearly calibration and does not require any injection of high concentration gas to reactivate his sensitive element.

The measurement will not be representative anymore of the concentration of gases or vapours if the detector is exposed too long time without oxygen or in a very dry atmosphere.

Characteristics of the device can also be altered by the presence of some poisons, such as silicon vapours.

## 1.5 Heating (DGi version only<sup>1</sup>)

In hard environmental conditions, with condensation or frost, gases and vapours may not reach the sensor. The device takes into account this difficulty and keeps its temperature slightly above that of the ambient atmosphere.

## 1.6 Technical specifications

Each detector is constructed as follows:

- A wall-mounted support secured by three screws and including cable gland (M20) (optional). There are 2 standard entries and an optional one.
- A stainless steel explosion-proof housing containing:
  - A set of tropicalized electronic cards
  - A display and infrared communication electronic card. Allowing the communication with the remote control (TLU600)
- A colour coded cartridge with a label located in the lower part of the detector, a green one for the toxic gas detectors with electrochemical cell (DGi-TT7-E), a blue one for the oxygen deficiency gas detectors with electrochemical cell (DGi-TT7-O) and an orange one for semi-conductor toxic gas detectors (DG-TT7-S)

The cartridge is connected to the detector's body by an open ring leaving the label visible. A colored ring enables the identification of the device type at a larger distance.

- A metallic support cable (optional) connects the wall mounting support and the housing, which makes the maintenance easier.

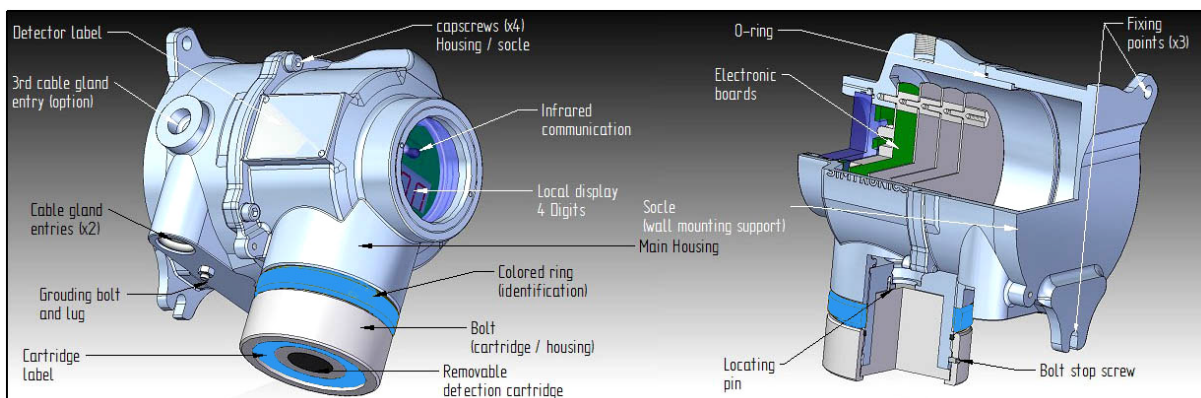

Figure 1 : Layout drawing

<sup>1</sup> With the exception of the DGi-TT7-D version, which has no heater

### 1.7 Detection cartridge

Detection cartridges are:

- Intrinsic safety "ia" for the DGi-TT7-E- and DGi-TT7-O versions. They can be removed when the detector is powered.
- Explosion proof "d" for the DG-TT7-S versions. They cannot be removed when the detector is powered.

They are common to all TELEDYNE OLDHAM SIMTRONICS MultiTox products in order to reduce the number of spares parts.

- DGi-RT7-E / DGi-RT7-O et DG-RT7-S: Network versions for Syntel loop,
- DGi-TT7-E / DGi-TT7-O et DG-TT7-S: « Telecapteur » versions,

Storing electrochemical cartridges (green or blue label) for long periods is not recommended, as their lifetime is short. Cartridges should be used within 6 months (from the date of purchase).

In order to guarantee the metrological characteristics of the device, the cartridges must be stored in their original packaging until commissioning and in clean atmosphere (no vapor of solvent). For a long-term storage, the cartridges will be stored in a dry place, between 5°C and 20°C.

After a long storage period, more than one month, the cartridge will be stabilized for several hours, in order to perform the nominal characteristics.

### 1.8 Commnication Interface

#### 1.8.1 Wireless Configuration Tool

Information and status of the detector are available via the wireless configuration tool TLU600.

Configuration and tests are performed using this wireless configuration tool (IrDA protocol). This tool is common for all TELEDYNE OLDHAM SIMTRONICS MultiFlame, MultiXplo and MultiTox products.

The TLU600 provides access to devices that, otherwise, would require major logistic operations for maintenance or for configuration (calibration...).

For more details, please refer to the wireless configuration tool operating manual.



## 1.8.2 Magnetic wand

The Type-D electronic version includes two magnetic sensors PG1 and PG2 implanted on the numeric card.

The communication interface is a magnetic wand. The wand gives access to information, state and configuration about the detector as the TLU (see §6.10).



## 1.8.3 HART communication

The HART communication authorizes an addressing of devices, allowing the communication in read/write mode.

It consists in getting connection on the current loop on which the numerical data are superimposed.

Most of the HART terminal can read these information and send commands

The use of a DD (Device Descriptor) facilitates the interface Man-Device. It can be uploaded on our website.

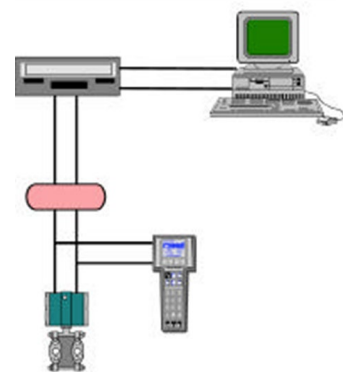

The HART output is an option. It is available only on the devices equipped with an electronic type C, in HART configuration (H): **DGi-\*\*7-\*\*\*\*-\*\*H-\*\*-\*\*\*-\*-C-**  
\*



TELEDYNE OLDHAM SIMTRONICS devices under HART protocol enable the use of all the functions available with the TLU600 via the HART terminal



See the document D1401002 for the using of Hart terminal TLH700 (the Detector Device Descriptor must be downloaded).

# MULTITOX DETECTOR

OPERATING MANUAL

## 1.9 Product Code

Product codes are created from functional codes defined as below:

DGi-**T7**-\*\*\*\*-\*\*-\*\***00J**-\***C**\* et DG-**T7**-\*\*\*\*-\*\*-\*\***00J**-\***C**\*

Detector type													
T	T	7	31	AF	-S	X	H	-C	0	-00J	-0	-C	-0
<b>C**</b>	Compact Sensor												
<b>T**</b>	Télécapteur												
<b>R**</b>	Network version												
<b>S**</b>	Replacement cell												
<b>X**</b>	Accessories												
Families													
<b>*T*</b>	Toxic												
<b>*X*</b>	Flammable gas												
<b>*0*</b>	None												
Version													
<b>**6</b>	BT606 housing												
<b>**7</b>	BT10 housing												
Gas type													
<b>**</b>	Refer to gas matrix												
Measurement range													
<b>**</b>	Refer to gas matrix												
Input Type													
<b>0**</b>	Not used or flame												
<b>E**</b>	Electrochemical												
<b>S**</b>	Semi-conductor												
<b>K**</b>	Catharometer												
<b>X**</b>	Catalytic												
<b>M**</b>	MECH												
<b>R**</b>	TOR input												
<b>C**</b>	Current input 0/22 mA												
<b>I**</b>	Infrared												
<b>W**</b>	½ Wheatstone bridge												
Variant													
<b>*A*</b>	Aluminium												
<b>*X*</b>	SS316												
Output Interface													
<b>**M</b>	1-2 mA protocol												
<b>**A</b>	0-22mA protocol (fault signalling in 0-4mA range)												
<b>**E</b>	4-20 mA protocol (Common fault signal 2 mA)												
<b>**H</b>	4 – 20 mA / 0-22 mA configurable & HART protocol												
<b>**C</b>	4 – 20 mA / 0-22 mA configurable												
<b>**W</b>	Wheatstone												
<b>**L</b>	LON												
<b>**X</b>	4 – 24 mA for compact explosimeter (magnet)												

DGi-TT7-E/O & DMi-TT6-E/O  
DG-TT7-S / DM-TT6-S

T	T	7	31	AF	-S	X	H	-C	0	-00J	-0	-C	-0	
								<b>Cartridges</b>						
								<b>O*</b>	No cartridge or not specified or flame					
DGi-TT7-O / Dmi-TT6-O								<b>M*</b>	Electrochemical type M					
								<b>G*</b>	Electrochemical type G					
DGi-TT7-E / Dmi-TT6-E / DGi-TT7-O / Dmi-TT6-O / DGi-TT7-D								<b>Y*</b>	Electrochemical type Y					
								<b>N*</b>	Electrochemical type N					
								<b>A*</b>	Electrochemical type A					
DG-TT7-X / DM-TT6-X								<b>D*</b>	Electrochemical type D7					
								<b>X*</b>	Catalytic					
DG-TT7-S / DM-TT6-S								<b>S*</b>	Semi-conductor (general designation for semiconductor type G)					
								<b>F*</b>	Semi-conductor type 30 (previously SF) since 2015					
								<b>C*</b>	Semi-conductor type 31 since 2015					
DG-TT7-K / DM-TT6-K								<b>K*</b>	Catharometer					
Half Wheatstone bridge probes								<b>E*</b>	EX05, EX09 (external)					
								<b>L*</b>	SX202-16					
								<b>T*</b>	SX202-10					
								<b>U*</b>	SX202-14					
								<b>V*</b>	SX202-17					
								<b>H*</b>	MTHX-S					
								<b>J*</b>	MTHX (/ , E, N, NE)					
								<b>W*</b>	SD122					
								<b>Z*</b>	SD122-01					
								<b>Semicond. Sensor type &amp; special configurations</b>						
								<b>*O</b>	Not specified or standard					
DG-TT7-S / DM-TT6-S								<b>*A</b>	20					
								<b>*B</b>	23					
								<b>*C</b>	24					
								<b>*D</b>	25					
								<b>*E</b>	27					
								<b>*F</b>	30 (become obsolete to release *R association)					
Options								<b>*K</b>	SD122 (EK)					
								<b>*M</b>	Special version MarED (TX6 and TV6 in type A only)					
								<b>*R</b>	With relay board for HW type D (gas)					
								<b>*T</b>	MTHX-S (ET)					
								<b>*X</b>	SX202 (EX)					
Customized versions								<b>*1</b>	Customized EPR (special follow up, SP4M20) (DM and DMi only)					
								<b>*2</b>	Customer T Customized version					
								<b>*3</b>	Network electronic board authorizing HWA & STEL					

# MULTITOX DETECTOR

## OPERATING MANUAL

T	T	7	31	AF	-S	X	H	-C	0	-00J	-0	-C	-0
										<b>Configuration</b>			
										000	Standard		
										**A	Absolutely no grease		
										**B	Special version MarED (old code) (TX6 and TV6 in type A only)		
										**D	IRDA cap instead of display		
										**E	0V not connected to housing ground on Tox type C		
										**F	TCM02 instead of IRDA cap		
										**G	Paint for nuclear application : BT606 paint + special colour RAL5012		
										**H	Special paint : light grey (10A03 according to « British standards 4800/5252 »)		
										**J	Special paint : red (RAL 3001)		
										**K	Machining of additional cable gland input		
										*L*	Paint thickness > 200 µm(ATEX versionIB)		
										M**	DGi without heating		
										<b>Language</b>			
										0	Fr / GB		
										F	French		
										E	English		
										P	Portuguese		
										C	Chinese		
										<b>Hardware version</b>			
										A	Type 63		
										B	Type 65		
										C	Type 67 (HART)		
										D	Type 69 (magnet)		
										<b>Software version</b>			
										0	Standard		
										1	Non-certified EN54-10 and/or SIL		

## 2 Technical features

### GENERAL

Type	Gas detector
DGi-TT7-E	MultiTox (electrochemical for toxic components)
DGi-TT7-O	MultiTox (electrochemical for measurement of oxygen)
DG-TT7-S	MultiTox (semi-conductor for toxic components)
DGi-RT7 / DG-RT7	Network detector
Calibration <sup>2</sup>	A test is recommended every 3-4 months on DGi -TT7-E and DGi-TT7 and every 6 months on DG-TT7-S.

### OUTPUT SIGNALS

Loop 4-20mA signal	Type active (source) maximum load impedance 700Ω
« 4-20mA » format (Factory set)	4-20mA with one fault level <ul style="list-style-type: none"> <li>• 0% full scale                    4 mA</li> <li>• 100% full scale                20 mA</li> <li>• 105% full scale                20.8 mA</li> <li>• Fault or inhibition            1.5 mA</li> </ul>
« 0-22mA » format	4-20mA with several fault levels, for PLC and some recent control units <ul style="list-style-type: none"> <li>• 0% full scale                    4 mA</li> <li>• 100% full scale                20 mA</li> <li>• &gt;105% full scale              20.8 mA</li> <li>• Inhibition                        3.4 mA</li> <li>• Fault measure                 2.6 mA</li> <li>• Device fault (HW/SW)        2.0 mA</li> </ul>
Output relays	3 x configurable relays max 1.7A / 30V <sub>AC/DC</sub> (optional) <sup>3</sup>

### POWER SUPPLY

Nominal voltage	24VDC, (18 – 35 V DC on versions DGi-TT7 or DG-TT7-S)
-----------------	-------------------------------------------------------

<sup>2</sup> These frequencies of calibration control are provided for information purposes only. The frequency depends on the operating conditions, the experience and safety requirements.

<sup>3</sup> This value changes to 1A when the security function uses the relays and the SIL level is required

(18 – 30 V DC on versions DGi-RT7 or DG-RT7-S)

### Consumption

	DGi-TT7 (with heater)	DGi-TT7 (without heater)	DG-TT7-S
Typical <sup>4</sup>	1.4 W Network : 2.8 W	1.4 W Network : 2.8 W	1.6 W Network : 3.1 W
Maximum	15W	5W	5W

Wiring	0,5mm <sup>2</sup> (20AWG)-2,5mm <sup>2</sup> (13AWG)
MTBF	303 600 h (Version DGi-TT7-E/O out of the cell) 392 500 h (Version DG-TT7-S including the cell)
<b>ENVIRONMENT</b>	
Storage temperature	see Operating (without cartridges) 5°C / 20°C with the cartridges type -E or -O Please refer to comments on storage conditions - §1.7
Operating	Please refer to table §3 for the operating temperature sensor range
Pressure	1013 Hpa ± 10%
Humidity	15 - 90% RH non condensing (version DGi-TT7-E/O) 5-100% RH non condensing (version DG-TT7-S)
Protection	IP66
RFI/EMI	EN 50270
Heating time <sup>5</sup>	60 sec to 120 sec depending on the version
Stabilization time	stabilization time 1st implementation or up to 24h after being powered off: <ul style="list-style-type: none"><li>- DGi-TT7-E : 2 hours</li><li>- DGi-TT7-O (type M): 10 min</li><li>- DGi-TT7-O (type Y): 1h30</li></ul>

<sup>4</sup> Typical power: voltage 24 Vdc, current 4 mA, display brightness 20%, temperature > 5°C (heating not activated)

Maximum power: voltage 35 Vdc, current 22 mA, maximum display brightness, relay card option, maximum heating

<sup>5</sup> The indicated warm-up time corresponds to the duration of inhibition measurement when powered on. It prevents from triggering alarms while signal is reaching its stabilised level. Nominal performances might be reached only after a stabilisation period.



# MULTITOX DETECTOR

OPERATING MANUAL

## DIMENSIONS

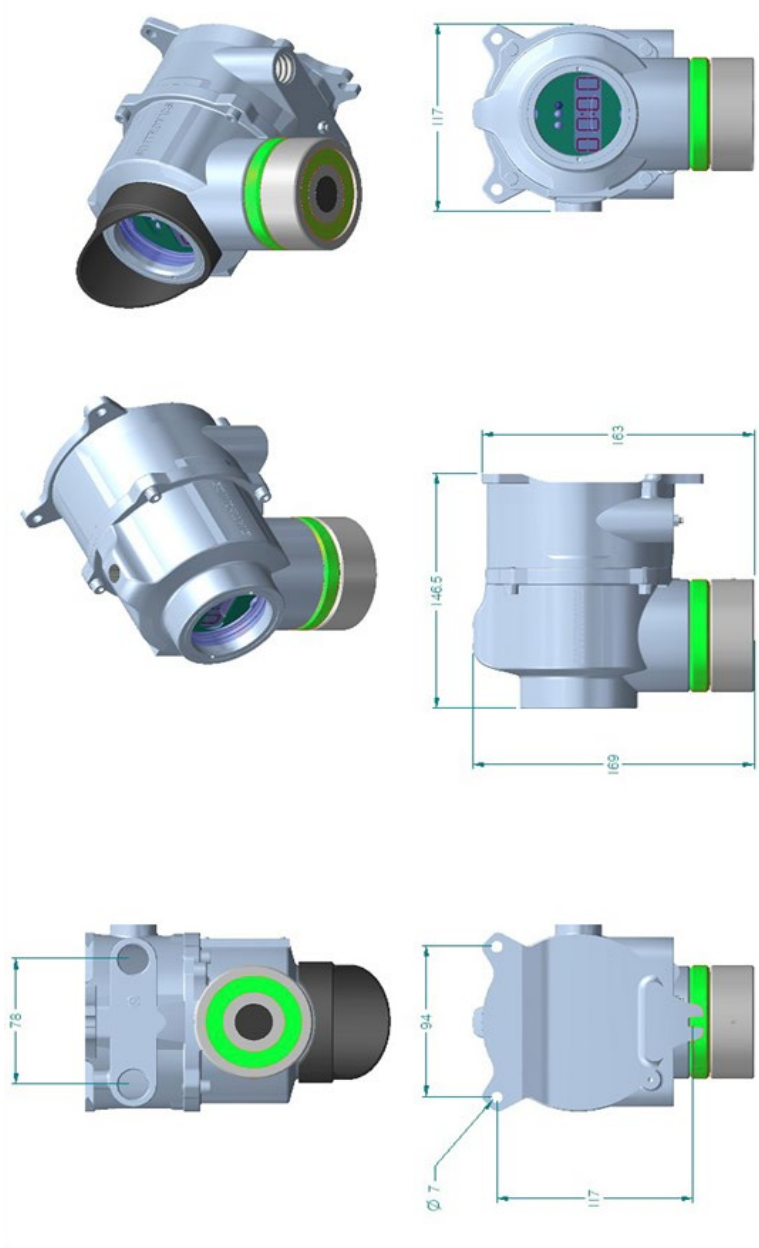

Figure 2 : Outline drawing (mm)

### 3 Scales and technical data

		Measurement range ①	$\tau$ (0-50%) (sec)	$\tau$ (0-90%) (sec)	Zero point stability ②	T° range (°C)	Accuracy ③ ④ ⑤	Lifetime (months)	Warming-up time or polarisation ⑥	Gas injection time (ref)
O <sub>2</sub>	DGI-TT7-O Type M	0-5 %vol	< 8	< 25	< 0.1 %vol	-10/+40	5 % scale	12 à 18	< 10 min	1'
		0-25 %vol					4 % scale			
O <sub>2</sub>	DGI-TT7-O Type Y	0-25 %vol	< 10	< 20	<0.3% vol	-40/+60	± 1.5% scale	5 ans	1h30	1'
O <sub>2</sub>	DGI-TT7-O Type G	0-25 %vol		< 20	< 0.1 %vol	+5/+50	± 1% Vol.	48	< 1 min	2'
H <sub>2</sub> S	DGI-TT7-E	0-20 0-50	<13	< 35	± 1 ppm	-20/+50	± 2 ppm ± 10 % reading	24	< 10 min	3'
		0-100 0-200			± 2 ppm		± 4 ppm ± 10 % reading			
H <sub>2</sub> S	DG-TT7-S	0-20 0-50	<30	< 70	<1 ppm	-40/+65	± 2 ppm ± 10 % reading ⑦	60	< 60 min	3'
H <sub>2</sub> S	DG-TT7-D ⑧	0-100	<15	< 70	± 2 ppm	-30/+60	± 4 ppm ± 10 % reading	>24	< 10 min	3'
NH <sub>3</sub>	DGI-TT7-E	0-50 0-100		< 120	± 2 ppm	-20/+40	± 4 ppm ± 10 % reading	24	< 10 min	4'
		0-1000			±20 ppm		± 25 ppm ± 10 % reading			
CO	DGI-TT7-E	0-100 0-200		< 35	± 4 ppm	-20/+50	± 4 ppm ± 10 % reading	36	< 10 min	2'
		0-500 0-1000			± 10ppm		± 15 ppm ± 10 % reading			
NO	DGI-TT7-E	0-100		< 20	± 3 ppm	-20/+50	± 4 ppm ± 10 % reading	36	< 60 min	1'
NO <sub>2</sub>	DGI-TT7-E	0-20		< 45	±0.5ppm	-20/+50	± 2 ppm ± 10 % reading	24	< 10 min	2'
H <sub>2</sub>	DGI-TT7-E	0-2000		< 70	±40 ppm	-20/+50	± 50 ppm ± 5 % reading	24	< 10 min	4'
		0-10000			±200 ppm		± 50 ppm ± 5 % reading			

# MULTITOX DETECTOR

## OPERATING MANUAL

		Measurement range ①	$\tau$ (0-50%) (sec)	$\tau$ (0-90%) (sec)	Zero point stability ②	T° range (°C)	Accuracy ③ ④ ⑤	Lifetime (months)	Warming-up time or polarisation ⑥	Gas injection time (ref)
SO <sub>2</sub>	DGi-TT7-E	0-20		< 30	±0.5ppm	-20/+50	± 2 ppm ± 10 % reading	24	< 10 min	2'
C <sub>3</sub> H <sub>3</sub> N	DGi-TT7-E	0-100	< 45	< 150	± 1 ppm	-20/+50	± 10 ppm	24	< 2h30 ⑨	5'

Table 1: performances

- ① In ppm unless otherwise indicated.
- ② Long term stability (21 days) under stable environmental conditions.
- ③ On the range: 0°C to 40 °C.
- ④ < 120 seconds at the 1st exposure.
- ⑤ The precision is estimated based on replication, linearity and temperature parameters.
- ⑥ Select the higher value where two tolerances are proposed.
- ⑦ Concerning the 0-100 ppm version, the accuracy is 20% on the range 50-100ppm.
- ⑧ For a 6 hours powered-off time.
- ⑨ Time to drop to 1 ppm (10 min to drop to 10 ppm).
- ⑩ Version without heater.



DG-TT7-S detectors: The silicone compounds are known to have poisoning effects on the semi-conductor element.



DGi-TT7-O detectors (type M): High CO<sub>2</sub> concentration (several %vol.) is known to have poisoning effect on the cell. In a similar way, solvents higher than 1000 ppm will gradually damage the cell.



DGi-TT7-O detectors (type Y): the solvent with alcohol and the alcohol containing antiseptic products, such as wipes and sanitizing gels have an impact on measurement.



DGi-TT7-O detectors: The measure is proportional to the partial pressure of oxygen in the measured mixture.

## 4 Installation

The detectors described in this manual are safety instruments intended to be installed in explosive atmospheres and have been designed in compliance with standards EN60079-0, EN60079-1, EN 60079-11, CEI 60079-0, CEI 60079-1 and CEI 60079-11.



Intervention in some sites may be subject to restrictions that we invite you to follow for your own safety and those of others.

---

### 4.1 Positioning

The detector must be positioned as close as possible to sources of potential leakages, taking into account airflows (e.g. upper and lower ventilation). The height is determined by the density of gas to detect.

Generally speaking, a detector will not be placed in front of an air inlet which brings clean air

This height may be adjusted to take into account the specific conditions which may interfere on the risk level (gas density, ambient temperature....)

### 4.2 Assembly

Use the two 7 mm diameter holes and the half slotted hole to secure the support.

It is highly recommended to install the support with cable-gland downward in order to avoid water infiltrations. In case of horizontal position, it is advised to make one or two loops with the cable at the entry of the cable-gland.

When mounting the cable gland (optional), if no tightening torque is specified by the manufacturer, consider that a tightening torque of 20N.m +/-10% is the most suitable.

On stainless steel housings, plugs are sealed with Loctite. If the plugs are moved or removed, it must be sealed again, using Loctite or equivalent.

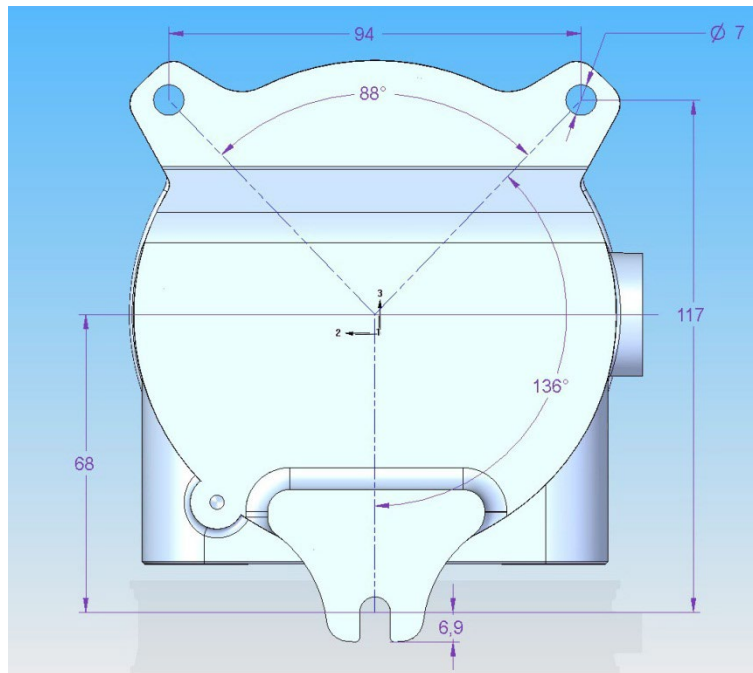

Figure 3 : Drilling dimensions for support fixing (mm).

### 4.2.1 Detector assembly

Check the presence and the good condition of the O-ring on explosion proof seal (no cracks, no cuts, good elasticity), make sure the flameproof joint is correctly greased and has no visible damage.

Plug connectors to the base, as described in paragraph "Electric connection".

Fit the main housing on the base, placing the cable excess in the base. Put in place and tighten the four M5 screws with their grower rings.

It is possible to set up a suspension cable (not supplied) between the base and the housing (at the lower part) with two threaded holes (M4 x 6).



Only the screws of property class A4-70 (yield stress  $\geq 450\text{MPa}$ ) must be used as a special fastener.

## 4.2.2 Cable's inputs (as an option)



Connection cables must pass through a cable gland (Explosion Proof certified)

---

For installation details, refer to the instructions provided by the manufacturer of the cable gland used.



The unassigned cable glands entries must be blanked with explosion proof certified plugs (M20). They are glued with Loctite (type tubétanche 577) or equivalent compound. If a plug is moved or removed, it must be glued again with Loctite or an equivalent.

---

## 4.2.3 Communication using the TLU 600

Communication elements are located above the display.



The orientation enables a communication with an  $\frac{1}{2}$  horizontal angle about  $35^\circ$ , an  $\frac{1}{2}$  vertical-up angle about  $30^\circ$  and a vertical-down angle about  $50^\circ$ .

The maximum communication distance is between 7 to 9 m.

## 4.2.4 Magnets identification

The magnets are identified by the "PG1" and "PG2" symbols on the housing.

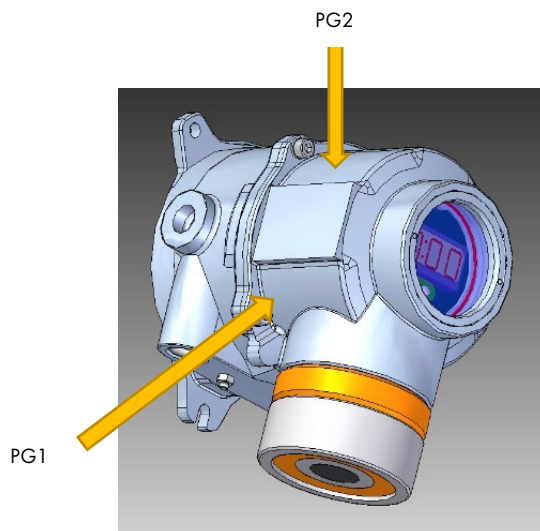

## 4.3 Electric Connection



Never adjust electric connections when detectors are powered. Maintenance must be undertaken by qualified staff. Observe safety site rules.

MultiTox are sensors with standard current output 4-20mA or 0-22mA. The connection can be on 3 or 4 wires. The 4 wires configuration allows insulation between the signal and power loops.

We recommend using an armoured and shielded cable, type NF M 87 202, in accordance with the requirements for hazardous areas and NF C 15 100. Other cables can be used if they are compliant with the local regulations and standards.

The table below shows the maximum cable lengths based on the wire cross section and the supply voltage delivered by the detection unit.

Min. single wire cross section mm <sup>2</sup> /AWG	0.5 (20)	0.9 (18)	1.5 (16)	2.5 (13)
Supply voltage 24VDC / 4W	288 m	505 m	893 m	1000 m
Supply voltage 24VDC -10% / 4W	173 m	303 m	536 m	926 m

NB : Those values are calculated for a minimum supply voltage of 18VDC at the sensor level and for the maximum consumption of the detector (5W)

### 4.3.1 Connection of the electrical ground braid

Use a shield connection clamp (not supplied) to connect the shielding of the cable to the electric ground of the housing (see § below).

### 4.3.2 Grounding

A M4 screw passes through the body of the enclosure, enabling the electronic ground of the housing to be connected to the local ground.

The armour of the power cable is normally connected to the ground of the detector, but it may depend on site practices.

External grounding must be done in accordance of the regulations in force.

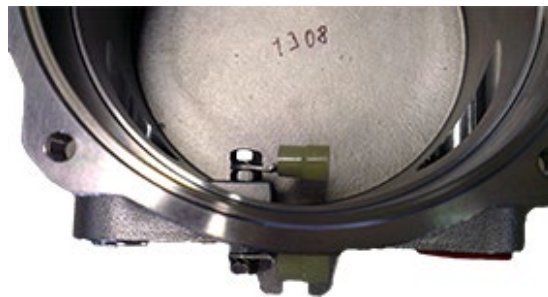

### 4.3.3 Connection

There are three different type of power supply:

- 3-wires connection (source):
  - The output current is not isolated from power supply, provided from detector (standard connection).
- 3-wires connection (sink):
  - The output current is not isolated from power supply, consumed by the detector
- 4-wires connection:
  - The output current is isolated from power supply

---

NB :The power potentials are isolated fromthe electric ground of the housing.

---

Total loop resistance:

Whatever the power supply type (3 wires source ou sink, 4 wires), the total loop resistance (resistor + cable) should not exceed the following value:

$$R_{\text{maxi}} = \frac{\text{Power supply voltage} - 8V}{22mA}$$

# MULTITOX DETECTOR

## OPERATING MANUAL

The total loop resistance should not exceed 700  $\Omega$  with a voltage of 24Vdc

### Terminal blocks :

Point	JP11	Description
1	V-	0 V retour
2	V+	+24VDC power supply
3	V+	+24VDC power supply loop (connected to point 2)
4	V-	0 V, connected to point 1
5	L+	20mA current loop : entry
6	L-	20mA current loop : output

#### 4.3.3.1 3-wires connection(source)

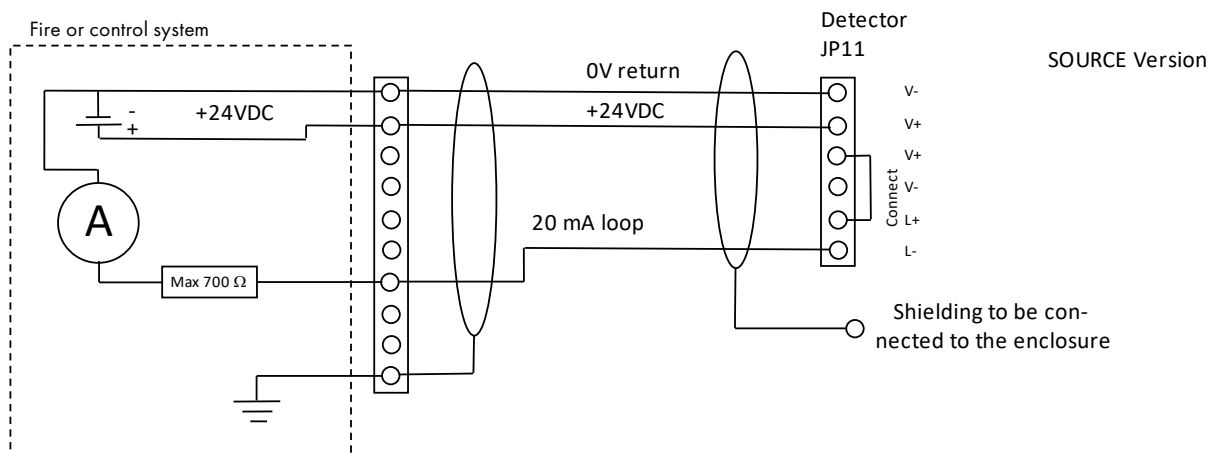

In this case, the output current is not isolated from power supply, provided from detector (standard connection).

The 20mA current loop must be supplied with 24 V at terminal L+. To proceed, connect the 3 (V +) and 5 (L +) terminals at the terminal block level of the device.

### 4.3.3.2 3-wires connection (Sink)

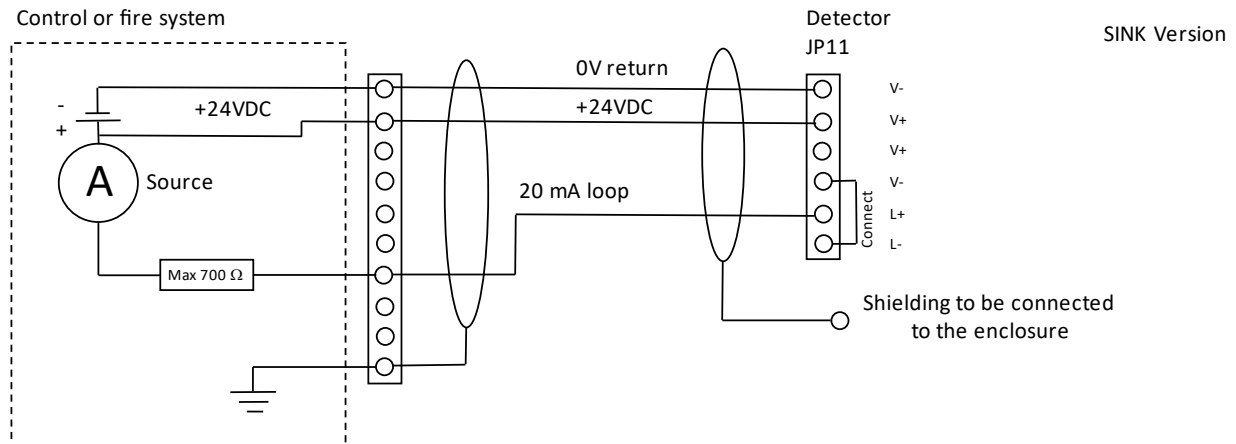

In this case, the output current is not isolated from power supply, consumed by the detector.

The 20mA current loop must be supplied with a PLC. The current return must be connected to the 0V at the level of the L- terminal. To proceed, please connect the 4 (V-) and 6 (L-) terminals at the terminal block level of the device.

### 4.3.3.3 4-wires connection (isolated power)

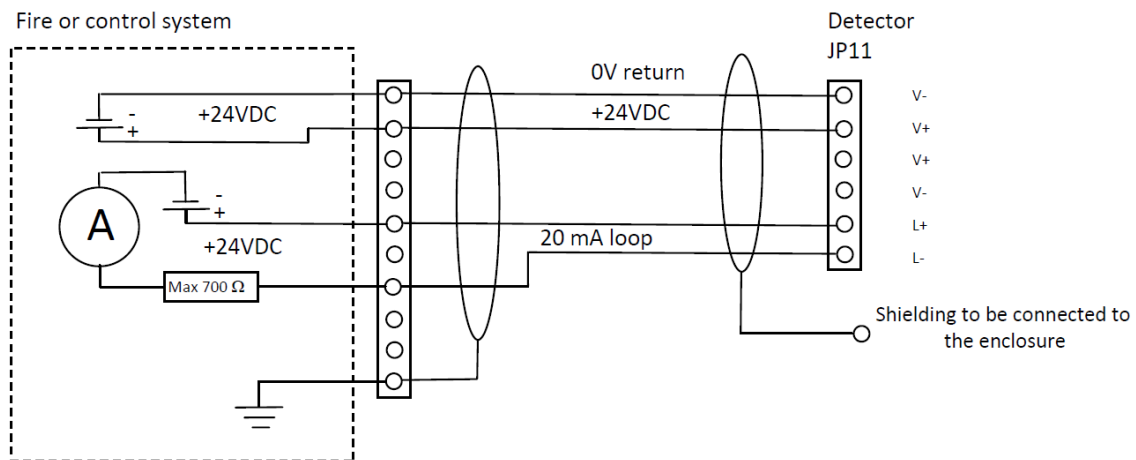

When using a 4 wires connection, the current loop is provided by the input module or PLC. The loop (L + and L-) is optically isolated from the detector. 4-20mA or 0-22mA input module of the PLC must power up the current loop with, at least 8V at the terminal level.

### 4.3.4 Relay (option)

An optional card with 3 relays can be added on the detector.

The output relays can be connected to the detection unit or warning devices.



For the network version, the optional relay card cannot be installed.

Each relay can be configured:

- normally closed or normally open.
- on one or more states of the detector (fault, permanent Inhibition, alarms).

Relays configured at factory setting : refer to § 6.8.6.1

### Relay card, terminal block (option):

Point	JP2	Description
1	C1	Relay 1 common
2	R1	Relay 1 de-energized
3	T1	Relay 1 energized
4	T1	Relay 1 energized
5	C2	Relay 2 common
6	C2	Relay 2 common
7	R2	Relay 2 de-energized
8	T2	Relay 2 energized
9	T2	Relay 2 energized
10	C3	Relay 3 common
11	R3	Relay 3 de-energized
12	T3	Relay 3 energized

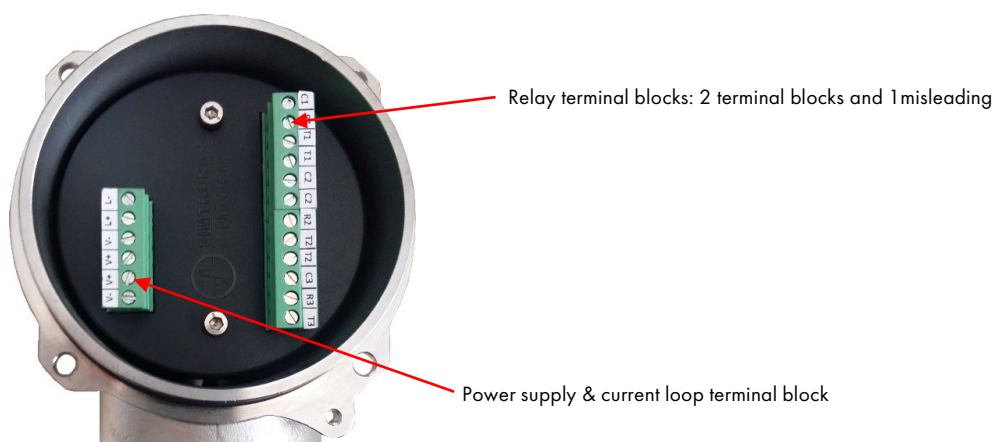

### 4.3.5 EOL Resistor



This applies to ATEX/IEC installations only. The EOL resistor must only be used inside the housing on the terminal block

The EOL resistor allows to a detection unit equipped with the line control function to ensure the continuity of the relay cable.

The EOL resistor must be placed on the relay contact connector to be monitored.

Maintain a 10mm minimum gap between the resistor and the terminal block or any other neighboring parts.

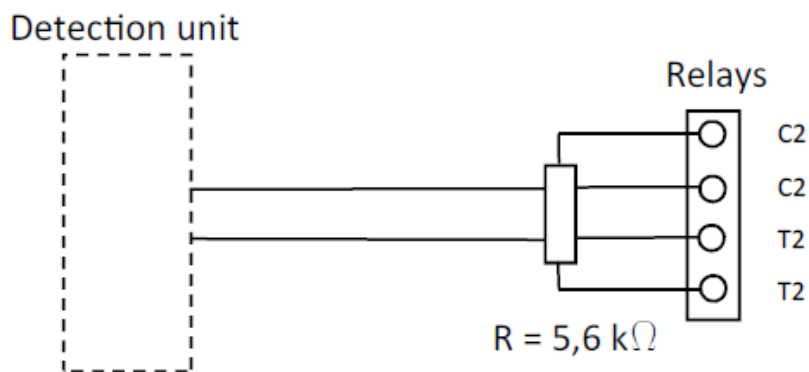

NB:

The R1 value is given as an indication. It must comply with the following conditions:

- Minimum consumption = 5 Watts
- Maximum dissipation = 2.5 Watts

### 4.3.6 Syntel connection

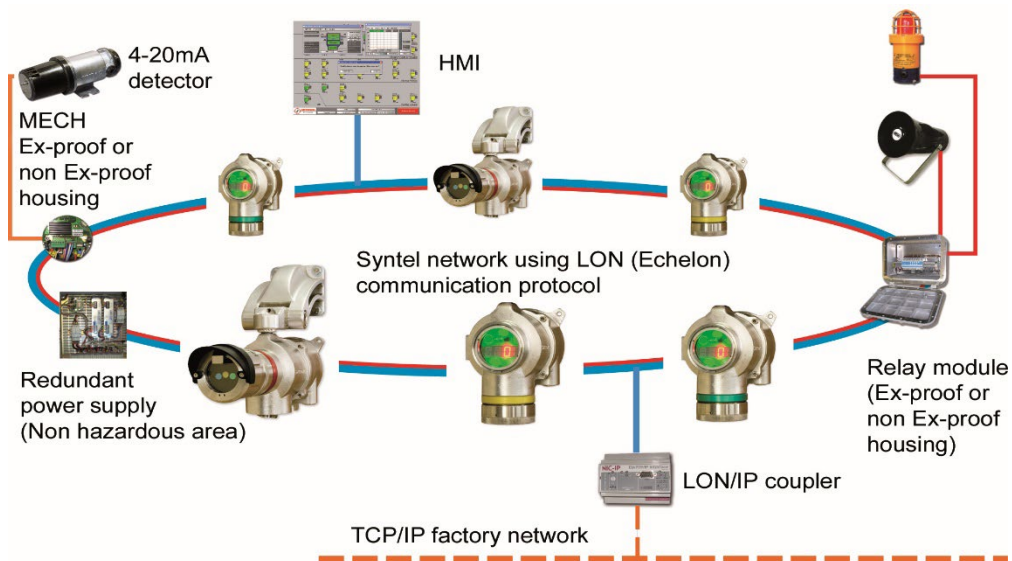

In this network version, an electronic board is inserted in the detector body and is used for electric connection.

Connecting the ground terminal should be performed thanks to 3-wire shielded cables.

The connection of power supply wires (4 on side A and 4 on side B).

- Two red wires on V +: +24 V
- Two white wires on V -: 0 V

Connection of the media wires (2 on side A and 2 on side B)

- A red wire on one of the N
- A white wire on the other N (no specific edge)

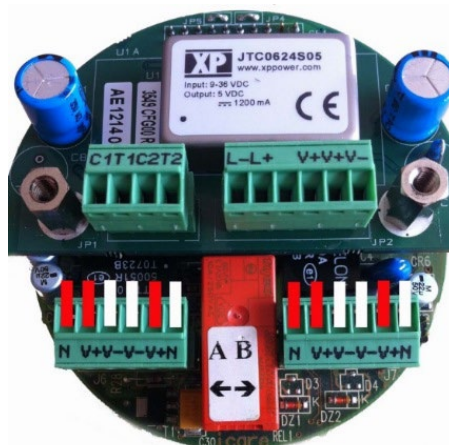

Figure 4 :Connecting drawing of the network versions



On board relays are not available on the digital version of the detectors

For more detail, please refer to the operating manual NOSP 15251

## 4.4 Detection cartridge

The cartridge is separated from the detector to enable its replacement. Its dismantling is extremely easy and does not need to touch the rest of the unit.



Caution during the assembly and the disassembly of the cartridge on the detector:

- Slide the positioning pin of the cartridge into the corresponding hole in the housing (at the bottom of the receiver).
- Take care to not damage the cartridge connector when tightening the two parts.
- On DGi-TT7-E and DGi-TT7-O versions, these operations can be performed when powered.
- On DG-TT7-S version, these operations imperatively require power to be off

Loosen the locking screw on the side of the nut (see Figure 1), then unscrew the nut, along the first part of the thread. With the nut, pull on the cartridge to remove it and then unscrew the cartridge from the nut.



Cartridges have an identification colour ring (see § 1.6).

Insert a new cartridge of the same colour into the case respecting the position defined by the centring pin, screw the nut until it stops ensuring the presence of O-ring. Then, tighten the locking screw.

Switch on the device in order to make the calibration of the new cartridge and the zero adjustment.

# MULTITOX DETECTOR

OPERATING MANUAL



## 5 Commissioning

### 5.1 Visual inspection

Make certain that all the operations of the "Installation" chapter have been achieved correctly.

Pay particular attention on installation conformity, check the cables entry, the presence of O-rings, and the connection of the cartridge.

- The label on the smart sensor indicates the type of detector, the type of gas and the range for which the instrument has been calibrated,
- The cartridge colour must correspond to the type of detector:
  - Green for toxic gas detectors with electrochemical cell
  - Blue for oxygen deficiency gas detectors
  - Orange for toxic gas detectors with semi-conductor cell

### 5.2 Power-up

The detector is powered through the multichannel detection unit or the Programmable Logic Controller.

- The backlight turns violet
- The display (red) appears. It displays, among other information, the INH which indicates the start-up inhibition and the warming-up remaining time in min and sec.
- After this warming up time, the backlight turns green and the current concentration is displayed.

### 5.3 Operational tests

All MultiTox detectors are delivered set and tested. Some additional tests are necessary to check the good working of the loop. Please make sure to have all authorizations needed before running the following operations:

- Check the states/information using the wireless configuration tool (TLU or TLH700) or the magnetic wand,
- Check the alarm levels
- Zero point: If there are no polluting gases or, if necessary, by injecting clean air at 30 l/h using the calibration kit equipped with an air cylinder
- Sensitivity: By injecting a suitable gas mixture at 30 l/h using the calibration kit
- Check the servo controls

# MULTITOX DETECTOR

OPERATING MANUAL



## 6 Operation

### 6.1 Environmental conditions

The lifetime of the electrochemical cartridges for toxic gas detector depends on the operating environment related to temperature, humidity and high exposures.

One will take care to avoid long exposures to a hot and dry atmosphere ( $T^{\circ} > 30^{\circ}\text{C}$  and  $\text{RH} < 10\%$ ), and gas exposures 4 times higher to the scale.

Concerning to DGi-TT7-O type Y, avoid using the detector in close to the solvents with alcohol or alcohol antiseptic products such as wipes and sanitizing gels.

The lifetime of the cartridges for semi-conductor toxic gas detector depends on the operating environment related to certain compounds.

One will take care to avoid exposures to some vapored products as silicone. Moreover, an exposure in area with a low rate of hygrometry for several hours can temporarily damage the sensitivity. In order to retain stability of the factory span calibration, we recommend to leave in place the protection cap with a desiccant packet on the front of the cartridge during storage, shipping or any periods without power lasting more than 1 hour.



---

Don't forget to remove the protection cap after power ON and before inserting the eventual splash-guard.

Store the protection caps with the desiccant packet in a sealed container (zip-lock bag). Dry the bag before using it again

---

In general, a dusty and humid atmosphere must be avoided. Indeed, a clogging of the gas barriers is then possible, slowing down or stopping the detection process.

## 6.2 Inhibition

Maintenance Inhibition is temporary. It appears during power up and maintenance.

Inhibition stops automatically when the operator gets out of the "maintenance" menus or after 10 minutes if communication with the TLU has been interrupted.

Maintenance inhibition can be configured in "frozen" mode (factory setting) or in "free" mode by the TLU or the Hart protocol. It cannot configure by the magnetic wand.

- In "frozen" mode, outputs (current and relay) remain in their previous state.  
For example, if the device indicated a failure (2.0 mA), this state would be maintained during the inhibition.
- If the unit is configured in "free" inhibition mode, the output current will be on the same level as for the permanent inhibition.

The permanent inhibition is activated by an order issued by the TLU, the TLH700 or the magnetic wand when an operation is performed at or around the device, or when the operator wants to inhibit a faulty device. The permanent inhibition must be removed by an operator's deliberate action using the TLU, the TLH700 or the magnetic wand.



As for the maintenance inhibition, this special mode is leading to a violet colour from the backlight.

---

### 6.3 Signal current loop

State	"4-20" [mA]	"0-22" [mA]	Display	TLU state
Line fault	0.0	0.0	DEF yellow Backlight	DEF
Configuration fault	1.5	2.0	DEF yellow Backlight	DEF
Detector fault (electronic)	1.5	2.0	DEF yellow Backlight	DEF
Measure fault	1.5	2.6	DEF yellow Backlight	DEF
Start inhibition	1.5	3.4	INH violet Backlight	Warming-up remaining time including power up
Permanent inhibition	1.5	3.4	INH violet Backlight	INH
Maintenance inhibition Fixed configuration (fault) / ("free mode") *	Previous value/ (1.5)	Previous value/ (3.4)	INH violet Backlight	INH
Alarm verification	21.7	21.7	DEF red Backlight	100% - DOUT DEF
≤ -10% of full scale	1.5	2.6	DEF yellow Backlight	DEF
-10% < concentration ≤ 0% of full scale (negative concentration not activated)	4.0	4.0	0% green Backlight	0%
-10% < concentration ≤ 0% of full scale (negative concentration activated)	2.4 < I ≤ 4.0	4.0	-10% < mes ≤ 0% green Backlight	-10% < mes ≤ 0%
0% of full scale	4.0	4.0	0% green Backlight	0%
25% of full scale	8.0	8.0	25% red Backlight if alarm reached green Backlight if alarm not reached	25% Alarm if level exceeded
50% of full scale	12.0	12.0	50% red Backlight if alarm reached green Backlight if alarm not reached	50% Alarm if level exceeded
75% of full scale	16.0	16.0	75% red Backlight if alarm reached green Backlight if alarm not reached	75% Alarm if level exceeded
100% of full scale	20.0	20.0	100%	100% Alarm
≥ 105% of full scale	20.8	20.8	red Backlight	> 100% Alarm

(\* ) Maintenance inhibition may be available in frozen or free mode.

### Display time:

The detector displays concentration or status. Depending on events, the detector displays cyclically important information according to the context: unit, gas, label, fault, alarms, inhibition and the time remaining inhibition....

### Output current (4-20mA ou 0-22mA) :

It can be modified by the user. See §6.8.6.2.

### Negative concentration:

The negative concentration display allows to anticipate the zero drift fault.

It can be modified by the user. See § 6.8.8.

## 6.4 Alarm indication

When an alarm status is confirmed, the backlight turns red. Moreover, the display indicates the alarm level and the current concentration.

The remaining information which is usually recorded in the display cycle are not provided anymore, in order to keep the detection and current alarm level as a priority.

If the alarm memorization is enabled, the backlight remains red and the alarm indication appears in the display cycle until the alarm is acknowledged with the TLU, TLH700(Hart) or the magnetic wand or until the detector is powered off, then powered on again.

If the alarm memorization is disabled, the backlight turns green when the alarm fades.



If the device is used in a safety loop in a potentially explosive area (EN60079-29-1), the upper alarm must be memorized, and a manual action must be taken to clear it.

---

## 6.5 Display indication

The 4 Digits display provides several information, depending on the state of the device:

### Starting:

- Display cycle : concentration and measuring scale (meas then % or ppm then gas)
- Alternately indicates the inhibition mode and the remaining warming up time

## Normal operating mode:

The digital readout provides the following information:

- Concentration
- Measuring scale
- Abbreviation of the gas used
- Label of the device



## In case of alarm:

- the display of concentration flashes
- alternation with « AL1 » or « AL2 » depending on the levels



## In case of default:

- The display shows « DEF »



## In case of inhibition :

- The display shows « INH »



## The modes of the backlight are:

Green	Normal use, no alarm
Red	Superior to the alarm level 1
Yellow	Fault mode
Violet	Inhibition mode ; maintenance (temporized or permanent)



At factory setting, the intensity of the backlight and the display self-adapt, depending on the brightness of the environment. The brightness can be adjusted at fixed levels, between 0 (off) and 100%



The electric consumption of the device depends on the background light level (see technical specifications).

## 6.6 Wireless communication tool TLU600

All settings and tests of detectors can be done by the wireless communication tool TLU600. This communication tool and its software are compatible with all TELEDYNE OLDHAM SIMTRONICS detectors: MultiFlame, MultiTox and MultiXplo. Communication is made via infrared link (IrDA), similar but more efficient than infrared links for computers. IrDA head should not be placed facing the sun as it significantly reduces the communication with the TLU600.

Please refer to the wireless communication tool operating manual for more details.



When a device is in communication mode with the TLU, its background light flashes. It enables the user to ensure he communicates with the requested device.

The TLU600 menu is composed of 2 access levels allowing both settings and obtaining information about detector's status.

- level 1 : exploitation
- level 2 : Maintenance

### 6.6.1 Main screen

The main screen is composed into several data fields.

C 1		C 2		C 3	C	
C 4					1	
C 5					0	
C 6		C 7		C 8		C 9

- C1: Detector name field
- C2: Field blank if normal operation; INH- if inhibited
- C3: Field blank if normal operation; FLT- if at least one fault has occurred
- C4: State of detection: no detection, cartridge fault
- C5: State of alarm: alarm, no alarm
- C6, C7, C8 and C9: Name of keys F1, F2, F3 and F4
- C10: Wireless communication tool pictograms

Main screen displays identity and state of the detector.

```
DGi-TT7
      0 ppm H2S
[0 ----- 100%]
INFO|ADJT|MAIN|FCNX
```

## 6.6.2 General operation

The user can navigate through the menu with the F1 to F4 keys, whose functions change depending on the fields displayed above each key. Standard functions:

- >>>> Scroll function / next screen.
- ESC Exit the current menu and return to the previous one.
- CHG Changing displayed value.
- VAL Validation and Check-in of the changed value.



The changed value must be confirmed by pressing [VAL] key, otherwise the old value will be kept when leaving the menu.

---

## 6.6.3 Menu structure

- Exploitation :  
This level enables access to the information and the status of the detectors. It does not allow the configuration operations or write access.
- Maintenance :  
The access to the parameters and other maintenance operations is protected by a password.

Default password (6 digits which can be changed): 012345.

# MULTITOX DETECTOR

## OPERATING MANUAL

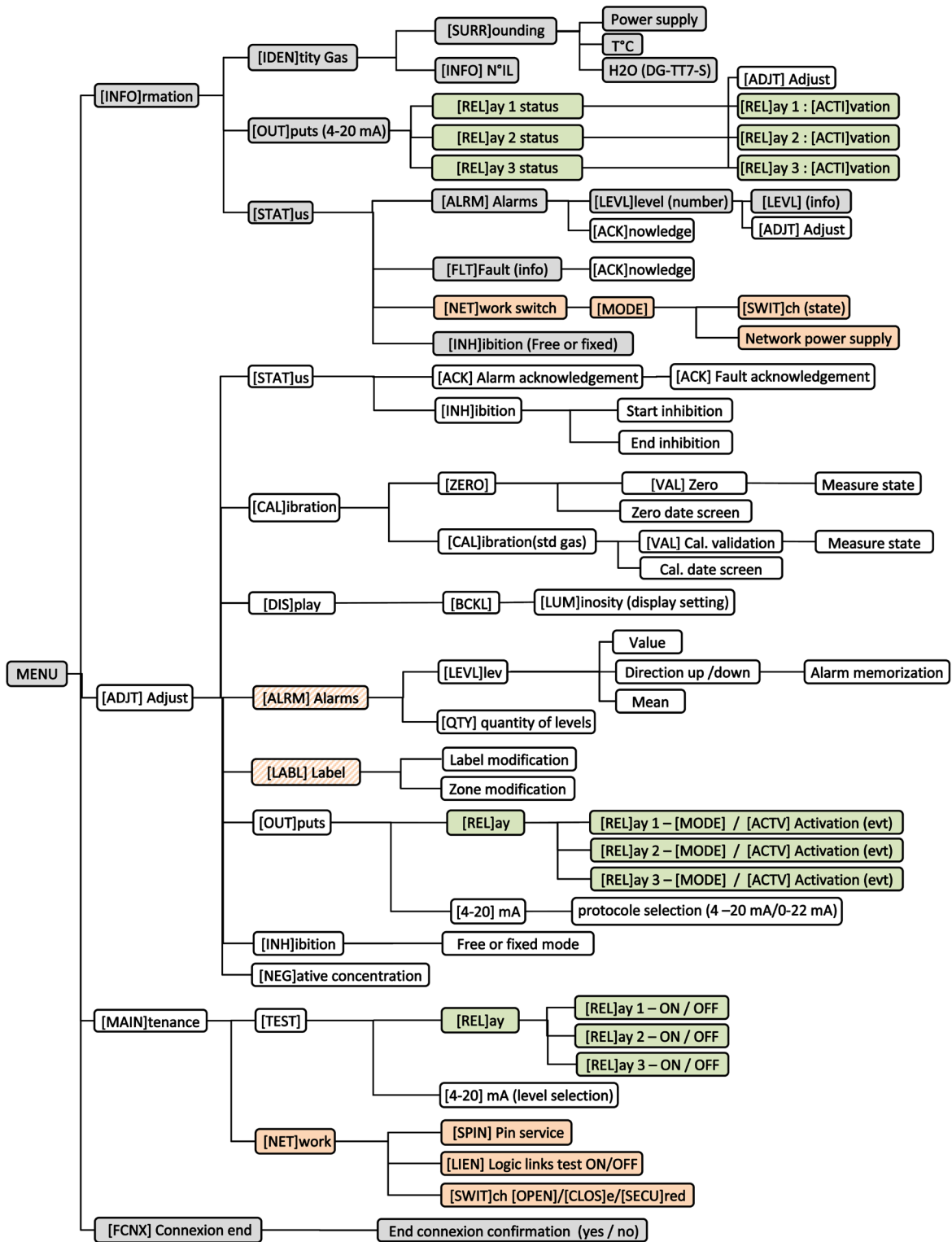

- Menus displayed without access code
- Menus displayed with relay board
- Menus displayed with Syntel board
- Menus not displayed with Syntel board

## 6.7 Information menu [INFO]

The information menu contains all information concerning the identity and settings of the detector. The first screen gives the detector's reference and its serial number.

### 6.7.1 [IDEN]tity submenu

Presentation of:

- The serial number
- The device reference
- The scale and the targeted gas

Sub-menus present the board software version, the power supply voltage and the temperature read in the cartridge.

### 6.7.2 [OUT]put submenu

Presentation of:

- Current protocol (0-20 mA or 4-20 mA).
- Normal state of the relays (normally open or normally closed).
- Condition of relay activation.

Relays can be set with a level 2 access.

### 6.7.3 [STAT]e Information submenu

Presentation of:

- Number and value of activated alarm levels.
- List of eventual faults (press F1 key to scroll through the list)
- Possibility to acknowledge alarms

#### 6.7.3.1 [ALRM] Alarm screen

Allows setting of levels and alarms acknowledgement.

#### 6.7.3.2 [FLT.] Fault screen

Displays a list of eventual faults (press F1 key to scroll through the list) and allows their acknowledgment.

#### 6.7.3.3 Network screen: switch state

This menu and its sub-menus are used for the network detector settings. For any further details, please refer to the Syntel system operating manuals.

### Mode screen

The first line shows the operating mode of the sensor in the network (logic link test / out of order / emulation).

The second line shows if the network part of the detector is “operating” or “out of order”. For any further details, please refer to the Syntel system operating manuals.

### Network screen: alim

Information displayed:

- Voltage A: ON / OFF
- Voltage B: ON / OFF

For any further details, please refer to the Syntel system operating manuals

#### **6.7.3.4 The INH screen:**

This screen is dedicated to verify the inhibition mode configuration (frozen or free). If the access level permits it, it is possible to change this setting.

## **6.8 Adjustment menu [ADJT]**

This menu presents all the detector settings. All the functionalities, except alarm level acknowledgment, request access level 2.

### **6.8.1 [STAT]us sub-menu**

#### **6.8.1.1 Alarm Acknowledgement**

This menu enables the acknowledgement of the stored alarms. The alarm can be acknowledged only if the alarm condition has disappeared.

#### **6.8.1.2 Inhibition / End of inhibition**

The inhibition (called permanent inhibition) is activated or deactivated manually using the menu. This function is used for deactivating the detector outputs (example: during maintenance).

The « inhibition » menu is available if the sensor is not in inhibition, maintenance inhibition or simulation.

Selecting the inhibition mode will switch the detector in inhibition mode.

The message “End of inhibition” is displayed on the TLU.

Press on “End of inhibition” to get the detector back to normal operating mode.

## 6.8.2 CALIBRATION sub-menu

### 6.8.2.1 Zero point setting

The operator can set the zero point with the wireless communication tool TLU600.

The detector is in maintenance inhibition mode for 10 minutes after it goes back to main screen.

Use the setting menu and validate the INH command for acknowledgement.

Press F4 key to stop communication between TLU600 and the detector.

With DG-TT7-S versions, if the environmental air potentially contains contaminants, the zero point setting should be carried out with a pressurized clean air cylinder. Use the calibration kit with in-line humidifying tube (specific calibration kit). Open the analytic air (30l/h) for 5 min and then start the zero point setting.

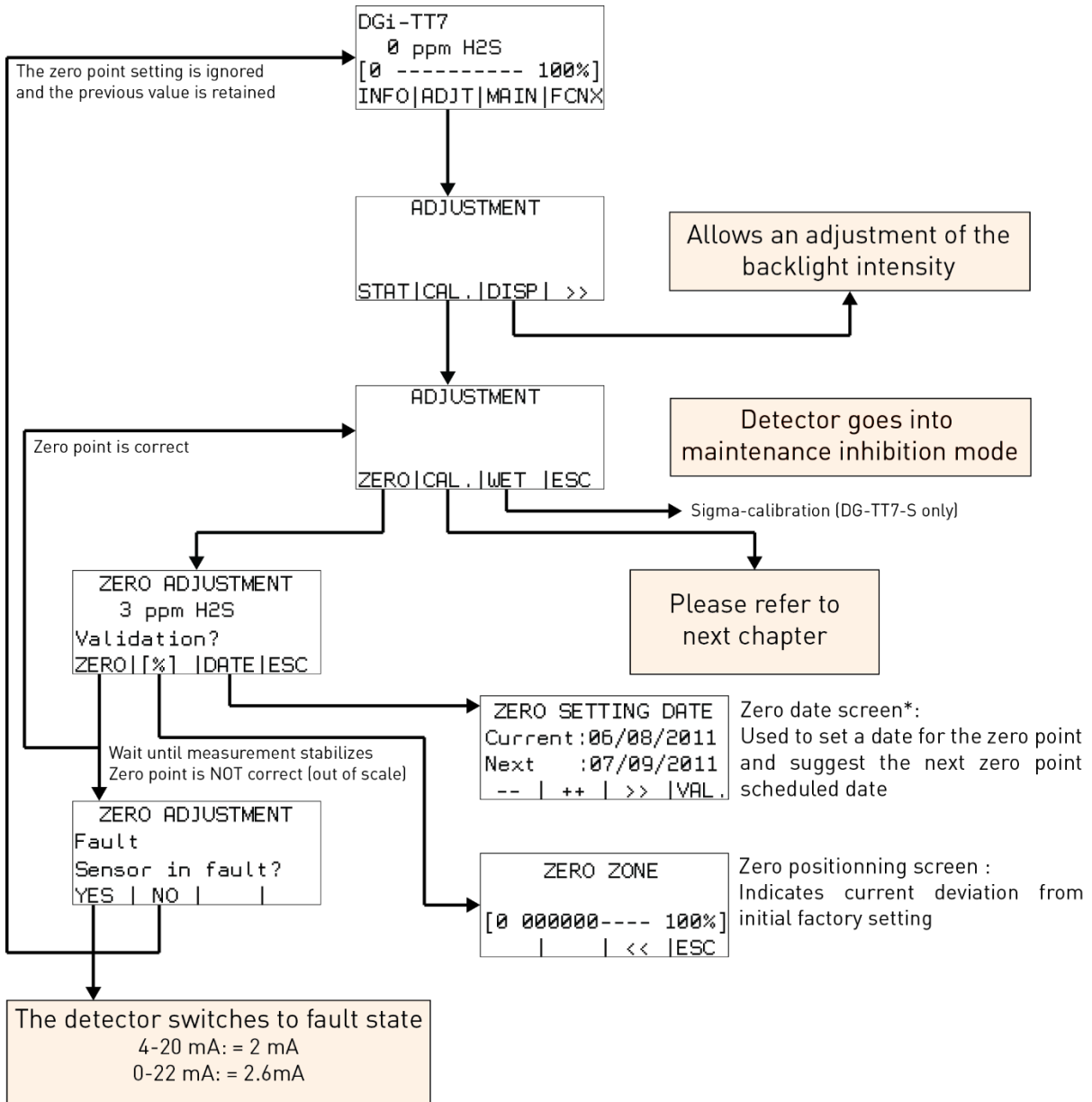

\* The device doesn't embed battery, it is then not able to keep real time. The date indication for zero or calibration points, as well as the next expected date for similar operations, are entered manually by the operator. Those data are for information only and their update is optional. mise à jour est facultative.

### 6.8.2.2 Calibration

Calibration must be made with the gas the detector is set to detect, with the SET menu (F2 key) of the wireless communication tool TLU600 and a calibration kit.

The calibration gas should be injected at a flow rate between 30 l/h and 60 l/h. For the DGi-TT7-O version, on a 25%vol scale, ambient air at 21%vol O<sub>2</sub> generally fits.

For DG-TT7-S series, it is necessary to have a humidifier tube into the gas circuit. Use the specific calibration kit.

Open the flow regulator (0.5 l / min), wait for stabilization (about 2-3 min)<sup>7</sup> and calibrate.

If one wants to carry out another bump test or calibration and expect an accurate measurement, a 60 minutes clean air recovery is considered as a minimum interval. This interval increases up to 90 minutes if the gas exposure has been about 5 minutes and extended to, at least, 2 hours if the gas exposure has exceeded 5 min.

---

**NB :** The humidifier tube provided in the calibration kit has to be change when the color becomes dark brown

---



---

**For DG-TT7-S versions, the H<sub>2</sub>S mixture must be in air and not in nitrogen otherwise a significant calibration error is made**

---

The detector is in maintenance inhibition mode for 10 minutes after it goes back to main screen. Use the setting menu and validate the INH command for acknowledgement.

To end of communication between the TLU6000 and the detector is done by pressing F4 key on main menu.

---

<sup>7</sup> When the splash guard (AS019) is used with the calibration cup, stabilization time increases slightly (approximately 1 minute) during an injection with cup.



### 6.8.3 [DISP]LAY sub-menu

This menu gives access to the light intensity setting of the backlight and display:

- AUTO : Automatic adjustment depending on the lighting environment
- Level 0 : Backlight is switched off, minimum display
- Levels 1 to 4 : Intermediary levels
- Level 5 : Maximum backlight intensity

### 6.8.4 [ALRM] Alarm sub-menu

The menu gives access to:

- The number of alarms levels used (0 to 4).
- The trigger's value of the alarm (levels values)
- The alarm's trigger sense (up or down)
- The alarm's memorization (yes/no)

On one hand, the alarm memorization maintains relays and alarm information on the wireless communication tool. On the other hand, the current output and the concentration displayed on the wireless communication tool are always updated with the real concentration

- VLEP functionality, i.e. activation of the calculation of gas exposure averages over a given period for certain alarm thresholds.

All thresholds can use averages instead of instantaneous values. Times can be set between 1 min and 1440 min (24h) with a resolution of 1 min. If this function has been activated :

- When inhibited, averaging continues as normal and alarms will be activated when this mode is exited.
- During maintenance inhibition, calculation is interrupted and the measured value is considered unavailable.
- When the sensor goes into fault, averaging uses the last known value as long as the duration of the fault condition does not exceed 20% of the associated averaging time. If the duration exceeds 20%, averaging is declared unavailable. Its calculation will be reinitialized when the fault disappear.
- If the scale is exceeded, both instantaneous and averaged values are displayed, but the value taken into account is that of the full scale.

On start-up or reset, the averages are initialized at the instantaneous value and will gradually evolve towards the average over the configured duration, which can potentially generate nuisance alarms.



**Caution:** configure all alarm thresholds as averaged values, which lengthens the detector's response time. For safety reasons, we recommend that you keep at least one instantaneous alarm threshold.

---



For a network detector, the alarm menu is unavailable.

---

### 6.8.5 [LABL] Label and [zone] sub-menu

This menu allows label and zone's modification. After selecting a label or a zone, the modification function operates in the same manner.

The numeric keys correspond to different alphanumeric characters. For each displayed page, the numeric keys have a different assignment.

Both "Label" and "Zone" fields are free text type for identification of the detector (name and position of the detector).

To edit fields select [label] or [zone].

- Press on the corresponding numeric key to select a figure
- Press [>>] to go to the next figure in the field
- Press [PAGE] to go next page

The label or zone modification must be confirmed by pressing the key VALID, otherwise the modification is not taken into account



For a network detector, the configuration data's (label, zone and alarms) cannot be modified.

---

## 6.8.6 [SORT] Output configuration sub-menu

### 6.8.6.1 Relays configuration

This menu gives access to the configuration of the relay operating mode and to conditions of activations.



This menu is available only with the optional relay card

---

#### State of the relays:

Each relay can be configured:

- Normally not energized
- Normally energized.

#### Activation of the relays:

Each relay can be activated on one or several following conditions:

- Alarm
- Fault
- Inhibition

#### Factory setting:

- Relay 1: normally energized, activated by any fault or inhibition
- Relay 2: normally not energized, activated on alarm levels
- Relay 3: normally not energized, activated on alarm levels

Contacts are then described as below:

Detector status	Relay 1 "Fault"	Relay 2 "Alarm"	Relay 3 "Alarm"
Normal (no alarm, no fault, no inhibition and detector powered)	C1-T1 closed C1-R1 open	C2-T2 open C2-R2 closed	C3-T3 open C3-R3 closed
Alarm	C1-T1 closed C1-R1 open	C2-T2 closed C2-R2 open	C3-T3 closed C3-R3 open
Ambiguity function (TX explosimeter only)	C1-T1 open C1-R1 closed	C2-T2 closed C2-R2 open	C3-T3 closed C3-R3 open
Fault or inhibition	C1-T1 open C1-R1 closed	C2-T2 open C2-R2 closed	C3-T3 open C3-R3 closed
Maintenance Inhibition (during maintenance mode)	Depend of configuration. See chapter 6.2		
Power loss	C1-T1 open C1-R1 closed	C2-T2 open C2-R2 closed	C3-T3 open C3-R3 closed

### 6.8.6.2 Output current configuration

This menu allows you to switch the format of the output current between 4-20 mA and 0-22 mA. Factory setting: the output current is 4-20 mA

### 6.8.7 [INH]ibition submenu

Maintenance inhibition can be configured in « frozen » mode (factory setting) or « free » mode.

- In « frozen » mode, the outputs (current and relay) remain in their previous state.
- For example, if the device displays a fault (2.0 mA), it will remain in this mode during the inhibition.
- If the device is configured in « free » mode, the current output will remain at the same level than the permanent inhibition

### 6.8.8 Sous-menu [NEG] Concentration négative

The detector can display the negative concentration. There is no sense from a point of physical view but it allows to prevent a zero drift and to have a preventive maintenance before the zero drift fault.

When the negative concentration is activated, the 4-20 mA output current is 3.2 mA when the detector displays -5% of full scale.

At factory setting, the negative concentrative is deactivated.

## 6.9 Maintenance menu [MAIN]

The maintenance menu allows the user to check if the detector is in normal operation conditions

- (Test of the relay and current outputs).

### 6.9.1 [TEST] sub-menu

#### 6.9.1.1 Relay menu

This menu gives access to activation or deactivation of the relays.

The detector switches to inhibition mode. The detector will stay in inhibition mode if the user goes back through the steps to the main menu. Otherwise, the detector will return to its "current" state.

#### 6.9.1.2 The 4-20 mA screen

This menu allows the output current to be set at a chosen value. The possible output values are: 1.5mA, 4mA, 8mA, 12mA, 16mA, 20mA or 22mA.

During this phase, the detector switches automatically to inhibition mode. The detector will stay in inhibition mode if the user goes back through the steps to the main menu. Otherwise, the detector will return to its "current" state.

### 6.9.2 NETWORK sub-menu

This menu gives direct access to different tests for the network. For any further details, please refer to the additional network operating manual:

- SPIN sends the detectors network identification.
- LIEN switches from normal mode to logic link mode.
- SWITCH enables the switches to go on mode open/closed/open secured.

## 6.10 Magnets operation

The digital display gives access to different menus.

To enter in these menus, the wand must put in place on the "PG1" or "PG2" magnet. The user must maintain the wand on the magnets with time longer or shorter depending on the desired function. The following symbols that appear on the display give indication of time:

- -: brief contact
- <: short contact corresponding to 1s
- <<: long contact corresponding to 2s
- <<<: very long contact corresponding to 5s

For example:

To operate a calibration gas, put the wand on the "PG2" sticker during 5 seconds until the symbol <<< appears. The display indicates "VIEW CONFIG". Put in place the wand on PG2 until "CALIB GAS" appears. Put the wand on PG1 during 1 second to enter in the menu. Depending on gas concentration injected, decrease the value with PG1 or increase it with PG2.

In his normal state, the detector displays every 30 minutes the gas unit, the gas, the label and the concentration. When the detector is in fault, the message "DEF" replaces the concentration. When the detector is in alarm, la concentration stays on the display.

Some function requires a code that is active for 10 minutes. This maintenance code can be change by the user ("0" means that the code is inactive, any value other than zero involves the code request to access to the desired function).

These codes are saved in case of shutdown or reset.



The menu about the relays is available only if there is no optional card. Only the relay state (energized / not energized) can be modified by the magnetic wand.

---



If you have a network card in the detector, the menu Alarm is unavailable.

---

# MULTITOX DETECTOR

## OPERATING MANUAL

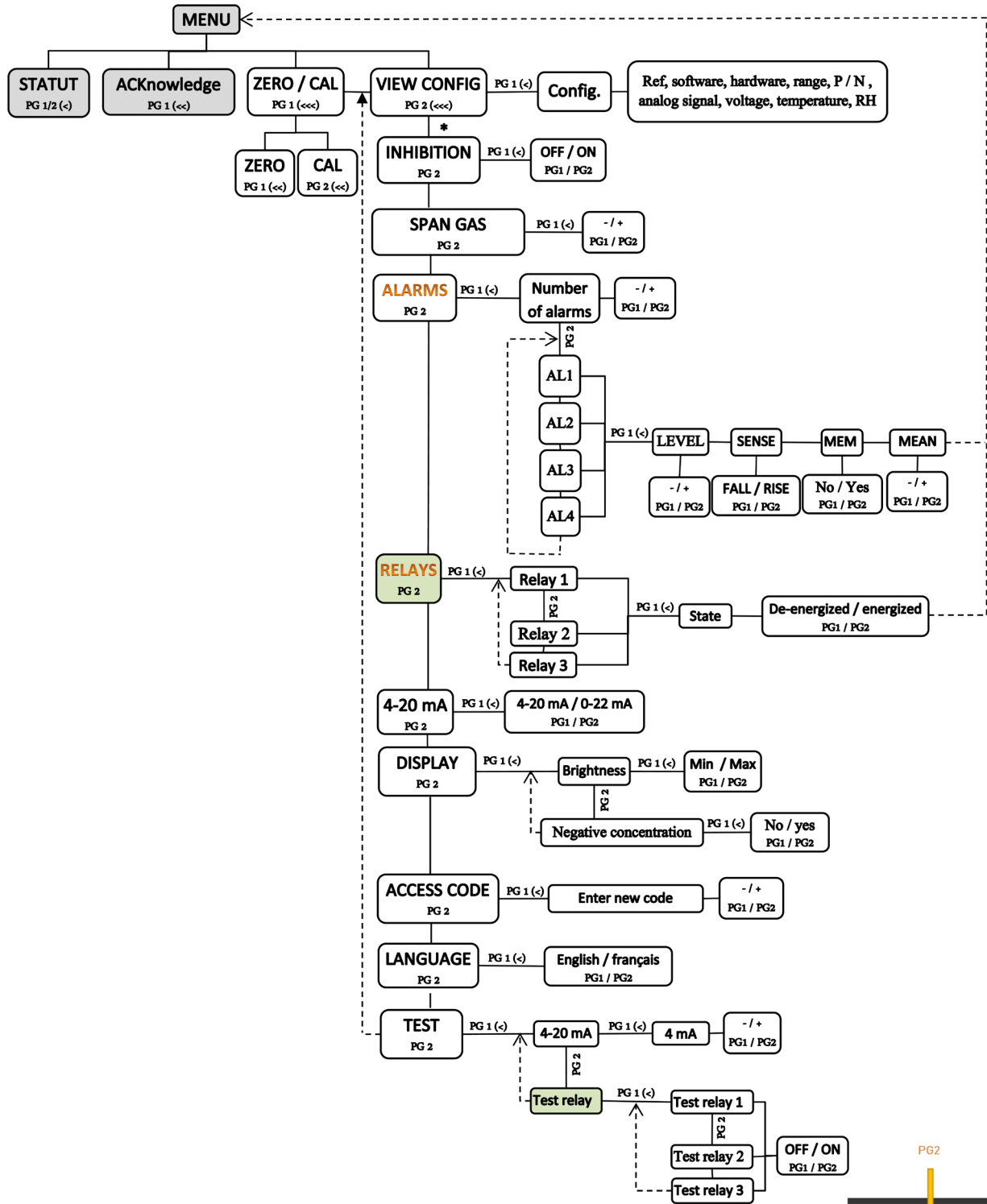

- AL** Menus not available with Syntel card
- Menus available with relay card
- Menus available without access code

\*Maintain the magnetic wand on PG2 to access at the different menus (inhibition, span gas,...)

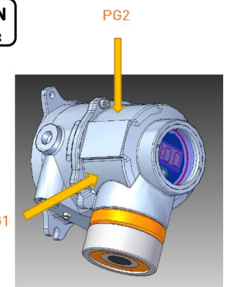

## 7 Maintenance



The interventions described in this chapter must be performed by competent and qualified staff. Device performances may be affected if the present instructions are not respected.

Cartridge replacement (DG-TT7-S only) and any other operation, imperatively require power to be off.

Cartridges on DGi-TT7 can be unplugged while power is on.

---

### 7.1 Open enclosure before Power off



All the power supply wires must be cut to put unpowered the detector

---

### 7.2 Periodic maintenance

Calibration control periodicity are provided for information purposes only. The frequency depends on the operating conditions, the experience and site requirements.

However, with regard to the functional safety certification of the device (SIL), an annual check is a minimum requirement.

#### 7.2.1 Preventive maintenance

A test is recommended every four months for the DGi-TT7-E or DGi-TT7-O versions, and every six months for the DG-TT7-S version.

Run a calibration if necessary. A zero point calibration with clean air (nitrogen for the DGi-TT7-O versions) has to be done first.



We recommend to use a mixture of the target gas with a 50% of the measuring range concentration. The complement of the mixture should, preferably, be Air (this is imperative for the DM-TT6-S version).

---

For any other operation, please contact your supplier or our technical services.

### 7.2.2 Corrective maintenance

If the detection unit or the PLC signals a detector fault, the detector must be tested directly with the wireless communication tool to determine the type of fault.

If the detector is configured in 0-22 mA output, it is possible to have a pre-diagnostic of the fault.

### 7.2.3 Loop test

In order to test the complete loop, several options can be used:

- Make a complete loop test by exposing the detector to gas
- Make a loop test in two parts by:
  - Manually switching the detector outputs thanks to the TLU remote as described in the section §6.9.1 in order to test the current and relays outputs
  - Exposing the detector to gas and watch the concentration on the display

Make sure that the elements connected to the detector (control system, fire panel or other extinguishing equipment) are under control, in order to avoid nuisance alarms.

Or any other operation, please contact your distributor or our technical services.

### 7.3 List of main faults

In addition of the current loop faults, other information are available from the wireless communication tool TLU600 (refer to §6.6). If the detector does not work properly, the following table can help you to determine the causes and effects of different possible

FAULTS		CAUSES	SOLUTIONS
Backlight display switched off		Power supply failure	Check the power supply (18 and 35 V <sub>DC</sub> ) at the detection unit or the PLC output
		Continuity issue	Check line continuity
No 4-20 mA / 0-22 mA signal	3-wire cabling	Power supply failure	Check the power supply (18 and 35 V <sub>DC</sub> ) at the detection unit or the PLC output
		Continuity issue	Check line continuity
		No shunt between V+ and L+	Place the shunt
No 4-20 mA / 0-22 mA signal		Power supply fault	Check the loop with an ammeter.
	4-wire cabling		
ZERO_FAULT (Zero point fault)		Zero point resetting impossible	Fault memorized, even on a power supply shut down. To acknowledge this fault, make a full calibration (in general, the sensor needs to be replaced).
DRIFT_FAULT (Zero point drift)		Sensor drift: the measure is below -10%	Non-memorized fault. Automatic acknowledgement when the measure goes back above -10%. Resetting the zero point is necessary.
CALIB_FAULT (Calibration fault)		Calibration resetting impossible	Memorized fault, even on a power supply shut down. To acknowledge this fault, make a full calibration (in general, the sensor needs to be replaced).
SELFTEST_FAULT SENSOR_FAULT (Fault material)		Material trouble (electronic part failure) on the sensor or on the electronic board of the detector	Non-memorized fault. Automatic acknowledgement when the detector is back to normal operation conditions. An electronic failure of the detector hardly happens. Replacing the cartridge will solve the problem most of the time.

FAULTS	CAUSES	SOLUTIONS
	This fault is triggered if there is no sensor in the detector.	
TEMPERATURE_FAULT (Temperature fault)	Temperature sensor is out of order or disconnected. The temperature sensor is in the cartridge.	Non-memorized fault. Automatic acknowledgement when the detector is back to normal operation conditions. Replace the cartridge.
No wireless communication tool connection	Detector unpowered	Check that the display is lighted
	Dialogue problem	Check the wireless communication tool by using it on another detector.
Detector fault (Material fault)	Electronic fault	Replace the detector

## 7.4 Replacing the cartridge

Follow the instruction in § 4.4.

## 7.5 Replacing the complete detector

If the operator needs to replace the complete detector, the easiest way is to take off the main housing from the base of the detector (for more details, refer to § 4.2.1).

As the base of the detector remains in place, cable glands do not need to be dismantled. If the detector is not replaced immediately, the “open” base must be protected against humidity, dust and shocks



No intervention should be performed while power is ON.

## 8 Certifications and standards

### 8.1 Functional Safety

DG-TT7-S is **SIL2** certified when the safety function is the current output and SIL1 when the safety function is the relays output

DGi-TT7-O is SIL2 certified when the safety function is the current output or the relays output.

DGi-TT7-E is SIL2 certified when the safety function is the current output et SIL1 when the safety function is the relays output.

In order to maintain the SIL level, the output current 4-20 mA or the output relay (if it is used) must be check every 12 months.

This verification is detailed in section 7.2.3 - Loop test.



Important: The SIL level indicated applies for a safety function using either the current outpur or the relay output.<sup>8</sup>

---

### 8.2 ATEX / IECEx Marking

The detector identification label is placed on the main housing, according to directives ATEX 2014/34/UE

- |                 |                            |
|-----------------|----------------------------|
| • Manufacturer  | TELEDYNE OLDHAM SIMTRONICS |
| • Model         | DGi-TT7...<br>DG-TT7...    |
| • Serial Number | S/N: xxxxxxxx (xxxxaamm)   |

---



<sup>8</sup> If the relay output is used as a safety function then the relays must be in factory setting to maintain the SIL level, namely:

- Relay 1: normally energized, activated by any fault or inhibition
- Relay 2 and 3: normally not energized, activated on alarm levels



# MULTITOX DETECTOR

## OPERATING MANUAL

### DGi-TT7

- Type of certification CE0080  II2G / Ex db ia IIC T6 Gb  
CE0080  II2G / Ex db ia IIB T6 Gb  
(2 mm > Paint thickness > 200µm)  
version : DG-T\*7-\*\*\*\*-\*\*\*-\*\*-\*[\*-\*\*-\*)  
-40°C < Ta < + 60°C
- Certificate number ATEX : LCIE 13 ATEX 3024X  
IECEX LCIE 13.0021X
- Warnings Warning - Do not open when energized. After de-energizing, delay 2 minutes before opening.
- Ingress rate IP66\*
- Maximum power supply voltage 35 Vdc
- Maximum consumption 15 w

### DG-TT7

- Type of certification CE0080  II2G / Ex db IIC T6 Gb  
CE0080  II2G / Ex db IIB T6 Gb  
(2 mm > Paint thickness > 200µm)  
version : DG-T\*7-\*\*\*\*-\*\*\*-\*\*-\*[\*-\*\*-\*)  
-40°C < Ta < + 65°C
- Certificate number ATEX: LCIE 11 ATEX 3081X  
IECEX: LCI 11.0060X
- Warnings Warning - Do not open when energized. After de-energizing, delay 2 minutes before opening.
- Ingress rate IP66\*
- Maximum power supply voltage 35 Vdc
- Maximum consumption 5 w

\* IP rating does not mean that the equipment will detect the gas during or after exposure to the defined conditions.

It is also recommended to use the device with the following accessories: AS056-250, AS019, AS015.



TELEDYNE OLDHAM SIMTRONICS does not allow any repairs of the flameproof joints and shall not be responsible for any modification of material.

---

## 8.3 Specific Conditions of use

User shall install Ex certified cable gland that do not degrade protection mode.

The detection element which can be mounted in the detection cell is defined in document +NOSP0016309, Rev 3 dated 2019/01/18.

Only the screw of property class A4-70 (yield stress  $\geq 450\text{MPa}$ ) must be used as a special fastener.

Security function of the thermic regulation (regulated by a temperature probe in the cartridge) must be complied with the SIL2 requirements according to EN 50495 / IEC 61508 standard.







# MULTITOX DETECTOR

OPERATING MANUAL



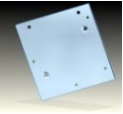





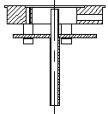

## 9 ACCESSORIES AND SPARE PARTS

### 9.1 Accessories

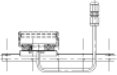
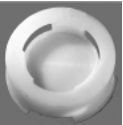
Accessories	Designation	Description	Part Number
	IRDA Remote control unit TLU 600	Required for adjustments and maintenance	TLU 600
	Remote control unit HART	Available for adjustments and maintenance	TLH 710 TLH720
	Adapting Plate (BT05-BT606-BT10)	Used to adapt old detector (BT05-BT606) attachments to fit new generation detectors (BT10 : DG, DGi)	AS049
	Calibration cup	Fits all cartridges	AS005 ① ⑤
	Tag plate	For on-site identification of detectors	AS215
	Calibration kit	The kit comprises: <ul style="list-style-type: none"> <li>• One air cylinder and one pressurized cylinder containing a mixture of air and a gas of titrated concentration,</li> <li>• A 30 l/H flow rate pressure reducing and regulating valve,</li> <li>• A 3 meter pipe.</li> </ul> The calibrating cup is not included in the calibration kit except for H <sub>2</sub> DM-TX6-X	CAL-K##-....
	Filter support	For use in certain situations with molecular filters in order to block out interfering gases.	AS015 ②

# MULTITOX DETECTOR

## OPERATING MANUAL

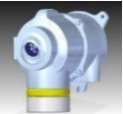
Accessories	Designation	Description	Part Number
	Remote calibration connection	Accessory enabling a gas supply tube to be attached near the cartridge.	AS016 ①
	Stainless steel sample flow with 2 ways	For use with gas circuit systems.	AS011-2X ①
	Duct mounting	A series of accessories for installing detectors on different types of ducts	AS02x ①
	Water, sand and dust protection	Adaptation to all cartridges, the assembly is directly in front of cartridge thanks to the nut of maintain (black on version -A).	AS019 ③
	Suspension cable enclosure/body	Enables to connect the enclosure with the body during the maintenance operations	AS052
	Tube mounting adapter	Enables DM-T#6, DMi-TT6, DG-T#7, DGi-TT7 et GD10P lines to be mounted on a 2 inch to 2.5 inch diameter tube	AS053
	Display protection	Enables to protect the infrared communication zone in order to better the dialog with the TLU in full sun	AS047
	Multiposition socket (wall or tube mounting)	Enables to fix the device from the top. Can be orientated in all directions.	AS048
	Weather protection (wall or tube mounting)	Dedicated to protect apparatus from sun / rain / snow.	AS056-250 ④
	IRDA cap	Replaces the display and its backlight by a fixed IRDA communication head	Configuration usine type OOD :
			DG-**-7- ***-**-** OOD-**-*

Accessories	Designation	Description	Part Number
	Magnetic wand	Required for adjustments and maintenance	AS055

- ❶ Detector sensitivity is not modified, response time depend on the flow rate used for injection. A flow rate between 0.5 L/min and 1 L/min should comply with "standard" response time.
- ❷ Detector sensitivity is not modified; response time can increase depending on the molecular filter used.
- ❸ Detector sensitivity is not modified, response time (T90) (natural diffusion condition) during the gaz exposure, is increased by 5%. When returning to air, T90 increase by 45%
- ❹ Detector sensitivity and response time are not modified.
- ❺ This accessory is included into the EN60079-29-1 Performance Certificate.



Wipe non-conductive parts (plastic) that can use in ATEX area with a damp cloth (risk of electrostatic charges)

## 9.2 Spare parts

- O-ring spare parts
  - For the base (All models) - O-ring kit BT10
  - For cartridge receiver
- Lubricant for explosion proof seal and thread: MOLYKOTE Brand, reference P40.
- Cartridges toxic gas detectors type -E: DMi-ST6-F1F2-EX0-ww
  - (F1&F2 to be specified, ww to be specified).
- Cartridges toxic gas detectors type -O: DMi-ST6-42F2-EX0-ww
  - (F1&F2 to be specified, ww=G0 or M0).
- Cartridges toxic gas detectors type -S: DM-ST6-F1F2-SX0-ww
  - (F1&F2 to be specified, ww=SF or SA).

## 9.3 Gas table codes & range table codes

According to the new references: DGI-TT7-F1F2-X□□-□□-□□□-□-□-□

DG-TT7-F1F2-X□□-□□-□□□-□-□-□

F1	Formula	Gas name	Comment	F2	Range
01	AsH <sub>3</sub>	Arsine		00	Pas
02	C <sub>2</sub> H <sub>2</sub>	Acetylene		AA	1 ppm
03	C <sub>2</sub> H <sub>4</sub>	Ethylene		AB	2 ppm
04	C <sub>2</sub> H <sub>4</sub> O	Ethylene oxide		AC	5 ppm
05	C <sub>2</sub> H <sub>6</sub> O	Ethanol		AD	10 ppm
06	C <sub>2</sub> H <sub>6</sub> O	Dimethylene		AE	20 ppm
07	C <sub>3</sub> H <sub>6</sub>	Propene		AF	50 ppm
08	C <sub>3</sub> H <sub>6</sub> O	Acetone		AG	100 ppm
09	C <sub>3</sub> H <sub>8</sub>	Propane		AH	200 ppm
10	i-C <sub>4</sub> H <sub>10</sub>	i-Butane		AJ	500 ppm
11	C <sub>5</sub> H <sub>12</sub>	Pentane		AK	1000 ppm
12	C <sub>6</sub> H <sub>14</sub>	Hexane		AL	2000 ppm
13	C <sub>6</sub> H <sub>6</sub>	Benzene		AM	5000 ppm
14	C <sub>7</sub> H <sub>8</sub>	Toluene		AN	10000 ppm
15	C <sub>8</sub> H <sub>8</sub>	Styrene		AP	3000 ppm
16	CH <sub>2</sub> Cl <sub>2</sub>	Dichloromethane		AQ	25 ppm
17	CH <sub>4</sub>	Methane		BA	1 %Vol
18	CH <sub>4</sub>	Methane	(Biogas)	BB	2 %Vol
19	CH <sub>4</sub> O	Methanol		BC	5 %Vol
20	Cl <sub>2</sub>	Chlorine		BD	10 %Vol
21	CO	Carbon monoxide	(H2S comp)	BE	20 %Vol
22	CO	Carbon monoxide		BF	50 %Vol
23	CO <sub>2</sub>	Carbon dioxide		BG	100 %Vol
24	CO <sub>2</sub>	Carbon dioxide	(CH4 immune)	BH	3 %Vol
25	COCl <sub>2</sub>	Phosgene		BJ	25 %Vol
26	X	All gases		BK	4 %Vol
27	CTFE	CTFE		BL	21 %Vol
28	CVM	Vinylchloride		BM	24 %Vol
29	F <sub>2</sub>	Fluorine		BN	17 %Vol
30	H <sub>2</sub>	Hydrogen		BZ	Other % vol
31	H <sub>2</sub> S	Hydrogen sulphide		DE	20 %LIE (1)
32	HCl	Hydrogen chloride		DF	50 %LIE (1)
33	HCN	Hydrogen cyanide		DG	100 %LIE (1)
34	He	Helium		DH	30 %LIE (1)
35	HF	Hydrogen fluoride		DJ	15 %LIE (1)
36	MCPE	MCPE		DP	125 %LIE (1)
37	N <sub>2</sub>	Nitrogen		EE	20 %LIE (2)
38	n-C <sub>4</sub> H <sub>10</sub>	n-Butane		EF	50 %LIE (2)

F1	Formula	Gas name	Comment	F2	Range
39	NH <sub>3</sub>	Ammonia		EG	100 %LIE (2)
40	NO	Nitric oxide		GC	5 LELm
41	NO <sub>2</sub>	Nitrogen dioxide		KA	1 ppm *m
42	O <sub>2</sub>	Oxygen		JB	2 ppm *m
43	O <sub>3</sub>	Ozone		KC	5 ppm *m
44	PFBA	PFBA		KD	10 ppm *m
45	R22	Chlorodifluoromethane		KE	20 ppm *m
46	R23	Trifluoromethane		KF	50 ppm *m
47	SO <sub>2</sub>	Sulphur dioxide		KG	100 ppm *m
48	C <sub>5</sub> H <sub>10</sub>	Cyclopentane		KH	200 ppm *m
49	VC <sub>2</sub>	VC2		KJ	500 ppm *m
50	D40	White Spirit		KK	1000 ppm *m
51	/	Gasoil		KL	2000 ppm *m
52	/	Super 95		KM	5000 ppm *m
53	/	Super 98		KN	10000 ppm *m
54	/	LPG		LH	200 ppm *m/100 %LEL *m
55	C <sub>2</sub> H <sub>5</sub> Cl	Ethyl chloride		LJ	500 ppm *m/100 %LEL *m
56	C <sub>2</sub> H <sub>6</sub>	Ethane		LK	1000 ppm *m/100 %LEL *m
57	C <sub>3</sub> H <sub>3</sub> N	Acrylonitrile/Vinyl cyanide		LM	5000 ppm *m /100 %LEL *m
58	C <sub>3</sub> H <sub>6</sub> Cl <sub>2</sub>	Dichloroethane		ZZ	Other
59	C <sub>3</sub> H <sub>6</sub> O	Propylene oxide			
60	C <sub>3</sub> H <sub>8</sub> O	Isopropyl alcohol			
61	C <sub>3</sub> H <sub>8</sub> O	Propyl alcohol			
62	C <sub>4</sub> H <sub>10</sub> O	Butanol			
63	C <sub>4</sub> H <sub>6</sub>	Butadiene			
64	C <sub>4</sub> H <sub>8</sub>	Butene			
65	C <sub>4</sub> H <sub>8</sub> O	Butanal			
66	C <sub>4</sub> H <sub>8</sub> O	Methyl-ethyl-ketone(MEK)			
67	C <sub>4</sub> H <sub>9</sub> O <sub>2</sub>	Ethyl acetate			
68	C <sub>5</sub> H <sub>10</sub> O	Methyl-isopropyl-ketone			
69	C <sub>5</sub> H <sub>10</sub> O <sub>2</sub>	Propyl acetate			
70	C <sub>5</sub> H <sub>12</sub> O	Isopentanol			
71	C <sub>5</sub> H <sub>8</sub>	Isoprene			
72	C <sub>6</sub> H <sub>10</sub>	D-limonene			
73	C <sub>6</sub> H <sub>12</sub>	Cyclohexane			
74	C <sub>6</sub> H <sub>12</sub>	Hexene-1			
75	C <sub>6</sub> H <sub>12</sub> O <sub>2</sub>	Butyl acetate			
76	C <sub>7</sub> H <sub>16</sub>	Heptane			
77	C <sub>6</sub> H <sub>4</sub> (CH <sub>3</sub> ) <sub>2</sub>	Xylene			

# MULTITOX DETECTOR

## OPERATING MANUAL

F1	Formula	Gas name	Comment	F2	Range
78	C <sub>7</sub> H <sub>12</sub> O <sub>2</sub>	N-butylacrylate			
79	C <sub>2</sub> H <sub>4</sub>	Ethylene	(special : low interf.C2H6)		
80	C <sub>3</sub> H <sub>8</sub>	Propane	(special: low interf. CH4)		
81	CH <sub>4</sub>	Methane	(special : low interf.C3H8)		
82	C <sub>8</sub> H <sub>18</sub>	Octane			
83	CF <sub>3</sub> -CFH <sub>2</sub>	R134a			
84	/	Kerosene			
85	C <sub>2</sub> Cl <sub>4</sub>	Tetrachloroethene			
86	C <sub>2</sub> H <sub>4</sub>	Ethylene	Special customer (EG)		
87	HC lourd	F1850	Special customer		
88	(CH <sub>3</sub> ) <sub>3</sub> COCH <sub>3</sub>	MTBE			
89	H <sub>2</sub> S + CH <sub>4</sub>	Hydrogen sulfide + Methane			
SA	Xs	Special combustible gas	App SA		
CS	H <sub>2</sub>	Hydrogen in Argon	Complement Argon		
CU	H <sub>2</sub>	Hydrogen in Azote	Complement Azote		

# MULTITOX DETECTOR

OPERATING MANUAL

# MULTITOX DETECTOR

OPERATING MANUAL



# MULTITOX DETECTOR

OPERATING MANUAL



**TELEDYNE**  
**OLDHAM SIMTRONICS**  
Everywhereyoulook™



**AMERICAS**

14880 Skinner Rd  
CYPRESS  
TX 77429,  
USA  
Tel.: +1-713-559-9200

**EMEA**

Rue Orfila  
Z.I. Est – CS 20417  
62027 ARRAS Cedex,  
FRANCE  
Tel.: +33 (0)3 21 60 80 80

**ASIA PACIFIC**

Room 2722,  
No. 51 Jinzang Road,  
SHANGHAI Free Trade Zone,  
CHINA  
TGFD\_APAC@Teledyne.com

[www.teledynegasandflamedetection.com](http://www.teledynegasandflamedetection.com)



© 2025 TELEDYNE OLDHAM SIMTRONICS. All right reserved.  
NOSP17668 Revision 06a / December 2025