

Instruction Manual

Model PI-700



PI-700 VOC Gas Sensor

This manual covers all ranges of PID based VOC Sensors



◆ TELEDYNE DETCON, Inc.
14880 Skinner Road, Cypress, Texas 77429
Phone 713.559.9200
www.teledynegasandflamedetection.com

Use and Disclosure of Data

Information contained herein is classified as EAR99 under the U.S. Export Administration Regulations. Export, reexport or diversion contrary to U.S. law is prohibited.

This page left intentionally blank

Table of Contents

1.	Introduction	1
1.1	Description	1
1.2	Sensor Electronics Design	1
1.3	Modular Mechanical Design	2
1.4	Intelligent Plug-in PID Gas Sensor	3
2.	Installation	4
2.1	Guidelines for Safe Use in Potentially Explosive/Hazardous Atmosphere	4
2.2	Sensor Placement	5
2.3	Sensor Contaminants and Interference	6
2.4	Mounting Installation	6
2.5	Electrical Installation	8
2.6	Field Wiring	9
2.7	Initial Start Up	10
3.	Operation	12
3.1	Programming Magnet Operating Instructions	12
3.2	Operator Interface	13
3.3	Normal Operation	14
3.4	Calibration Mode	15
3.4.1	AutoZero	15
3.4.2	AutoSpan	15
3.5	Program Mode	17
3.5.1	Navigating Program Mode	17
3.5.2	View Sensor Status	18
3.5.3	Set AutoSpan Level	19
3.5.4	Set Serial ID	20
3.5.5	Set Range	20
3.5.6	Set Gas Factor	21
3.5.7	Set Zero Offset	21
3.5.8	Signal Output Check	21
3.5.9	Restore Factory Defaults	22
3.6	Program Features	22
3.6.1	Operational Features	22
3.6.2	Fault Diagnostic/Failsafe Features	23
4.	RS-485 Modbus™ Protocol	25
5.	Service and Maintenance	27
5.1	PID Plug-in Sensor Maintenance	27
5.2	Replacement of Intelligent Plug-in sensor	35
5.3	Replacement of ITM	36
5.4	Replacement of PI-700 Sensor Assembly	36
6.	Troubleshooting Guide	37
7.	Customer Support and Service Policy	40
8.	PI-700 Sensor Warranty	41
9.	Appendix	42
9.1	Specifications	42
9.2	Gas Reference Table	44
9.3	Spare Parts, Sensor Accessories, Calibration Equipment	51
10.	Revision Log	52

Table of Figures

Figure 1 Typical Sensor Cell.....	1
Figure 2 ITM Circuit Functional Block Diagram.....	2
Figure 3 Sensor Assembly Front View	2
Figure 4 Sensor Assembly Breakaway.....	3
Figure 5 Intelligent Plug-in Sensor Assembly Breakaway.....	3
Figure 6 Outline and Mounting Dimensions (Sensor Assembly only).....	6
Figure 7 Outline and Mounting Dimensions (Stainless Steel Junction Box)	7
Figure 8 Outline and Mounting Dimensions (Aluminum Junction Box).....	7
Figure 9 Typical Installation	8
Figure 10 Sensor Wire Connections.....	10
Figure 11 Magnetic Programming Tool.....	12
Figure 12 Magnetic Programming Switches	12
Figure 13 UV Lamp Aging Expectation	27
Figure 14 Splashguard Adapter with Integral Filter.....	29
Figure 15 Plug-in sensor with Moisture control packet	29
Figure 16 Sensor Cell Parts.....	30
Figure 17 Removal of Filter Cap.....	30
Figure 18 Removal of Filter Media.....	31
Figure 19 Removal of Spacer.....	31
Figure 20 Removal of Cell Assembly	31
Figure 21 Removal of Lamp	32
Figure 22 Lamp cleaning.....	32
Figure 23 Polishing the Lamp	32
Figure 24 Lamp installation	33
Figure 25 Lamp seating.....	33
Figure 26 Cell Assembly installation	33
Figure 27 Spacer installation.....	34
Figure 28 Installing Filter Media.....	34
Figure 29 Replacing the Cap.....	34
Figure 30 Sensor Assembly.....	35
Figure 31 Sensor Cell and ITM Mating	35
Figure 32 Sensor Cell and ITM Mating	37

List of Tables

Table 1 Wire Gauge vs. Distance.....	9
Table 2 Maximum and Minimum AutoSpan Settings.....	19
Table 3 Modbus™ Registers.....	25
Table 4 Modbus™ Special Registers	26
Table 5 Gas Factor Table	44

Shipping Address: 14880 Skinner Road, Cypress, Texas 77429
 Phone: 713.559.9200

<http://www.teledynegasandflamedetection.com> • detcon-sales@teledyne.com

1. Introduction

1.1 Description

Teledyne Detcon Model PI-700 VOC gas sensors are non-intrusive “Smart” sensors designed to detect and monitor a wide range of VOC and Toxic gasses in air. Ranges of detection for target gasses are from 0-1ppm up to 0-5,000ppm. The sensor features an LED display of current reading, fault and calibration status. The Sensor is equipped with standard analog 4-20mA and Modbus™ RS-485 outputs. A primary feature of the sensor is its method of automatic calibration, which guides the user through each step via fully scripted instructions displayed on the LED display.

The microprocessor-supervised electronics are packaged in an encapsulated module and housed in an explosion proof casting, called the ITM (Intelligent Transmitter Module). The ITM includes a four character alpha/numeric LED used to display sensor readings, and the sensor’s menu driven features when the hand-held programming magnet is used.

Sensor Technology

The sensors are based on plug-in replaceable miniature PID (Photo-Ionization Detector) sensor technology. The sensor is sensitive to ambient gases that have ionization potentials of $< 10.6\text{eV}$, making it highly sensitive but extremely non-specific. The sensor responds to most toxic VOC compounds and many other toxic gases as well. The sensor is comprised of a UV lamp covered by a specific optical filter which projects only radiation in the 10.6eV range. Target gases that diffuse into the sensor chamber with ionization potentials of $< 10.6\text{eV}$, are ionized by the radiation and give up free electrons. The free electrons are captured by the high voltage collection grid and provide a current that is directly proportional to the concentration of the target gas.

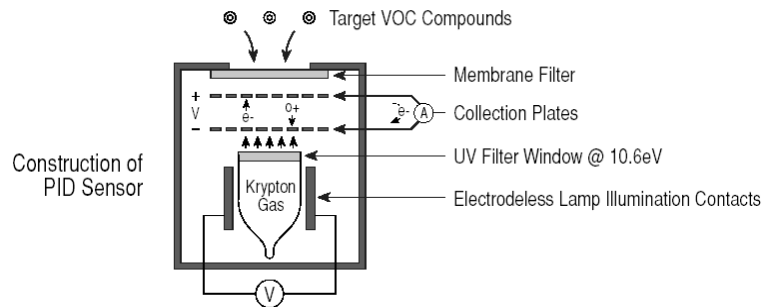

Figure 1 Typical Sensor Cell

1.2 Sensor Electronics Design

Intelligent Transmitter Module

The PI-700 Intelligent Transmitter Module (ITM) is a fully encapsulated microprocessor-based package that is universal in design and will accept any Teledyne Detcon intelligent plug-in PID gas sensor. The ITM design uses an internal intrinsically safe barrier circuit that lifts the requirement for use of flame arrestors to achieve Class 1, Division 1 (Zone 1) area classification. This facilitates fast response times and improved calibration repeatability on strongly absorbing gas types. The ITM circuit functions include extensive I/O circuit protection, on-board power supplies, internal intrinsically safe barrier circuit, microprocessor, LED display, magnetic programming switches, a linear 4-20mA DC output, and a Modbus™ RS-485 output. Magnetic program switches located on either side of the LED Display are activated via a hand-held magnetic programming tool, thus allowing non-intrusive operator interface with the ITM. Calibration can be accomplished without declassifying the area. Electrical classifications are Class I Division 1 Groups A, B, C, D, Class I Zone 1 Group IIC, and are ATEX & IECEx approved for II 2G Ex db ib IIC T4 Gb.

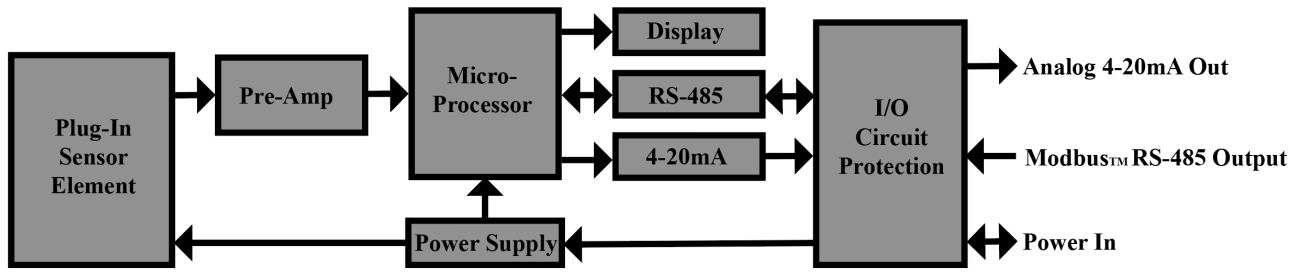

Figure 2 ITM Circuit Functional Block Diagram

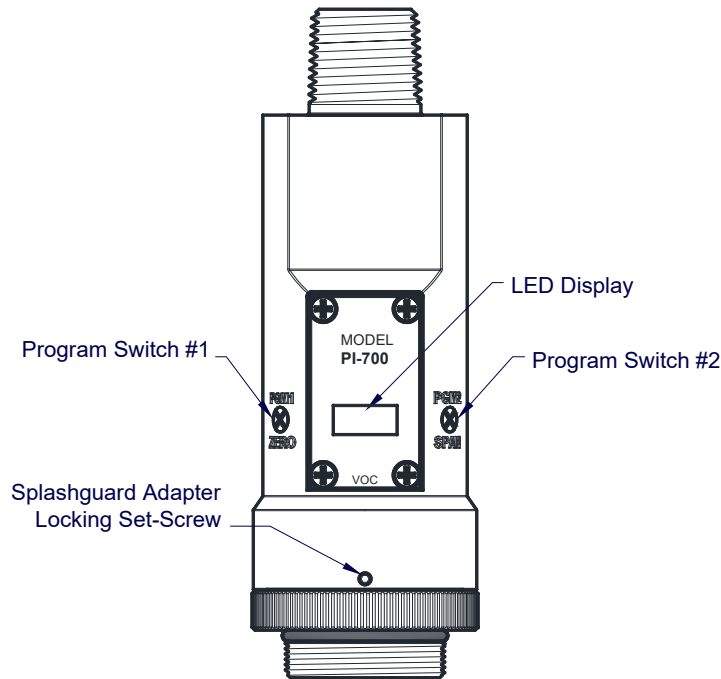

Figure 3 Sensor Assembly Front View

1.3 Modular Mechanical Design

The Model PI-700 Sensor Assembly is completely modular and is made up of four parts (See Figure 4 for Assembly Break-away):

- 1) PI-700 Intelligent Transmitter Module (ITM)
- 2) Intelligent Plug-in Sensor (varies by range)
- 3) PI-700 Splash Guard Adapter with Integral Filter
- 4) Splash Guard.

NOTE: All metal components are constructed from electro polished 316 Stainless Steel in order to maximize corrosion resistance in harsh environments.

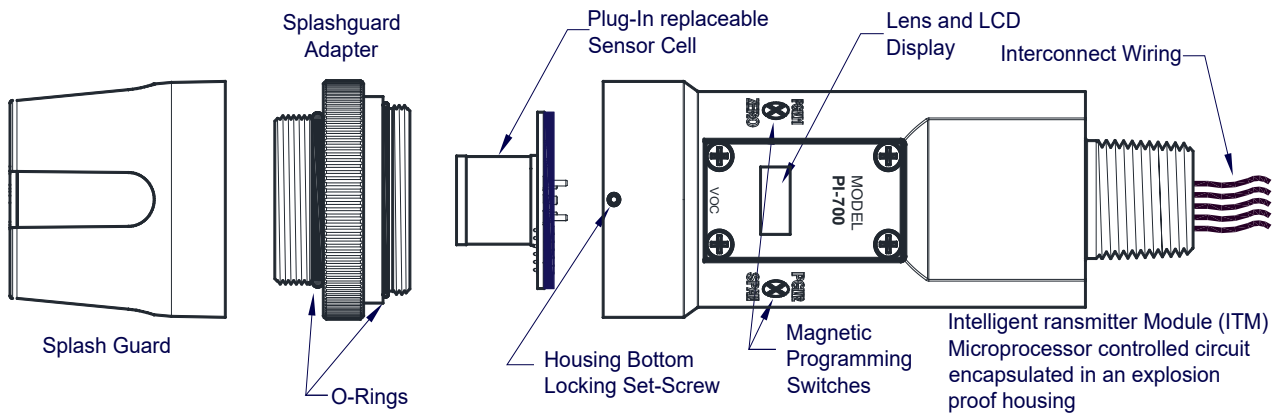

Figure 4 Sensor Assembly Breakaway

1.4 Intelligent Plug-in PID Gas Sensor

The Teledyne Detcon range of PID gas sensors are field proven, intelligent plug-in sensors (one type is used for ranges of 20ppm and less, another is used for ranges greater than 20ppm.) The Sensors employ 100% encapsulated circuitry and over-sized gold-plated connections that eliminate corrosion problems. The intelligent design provides automatic recognition of gas type, units, full-scale range, and calibrations data when a new sensor is plugged in. The sensor can be accessed and replaced in the field very easily by releasing the locking setscrew and unthreading the Splashguard Adapter. The PID Sensor cell can be disassembled so that the lamp used can be cleaned or replaced. Teledyne Detcon’s ranges of PID sensors has a long shelf life and are supported by an industry-leading warranty.

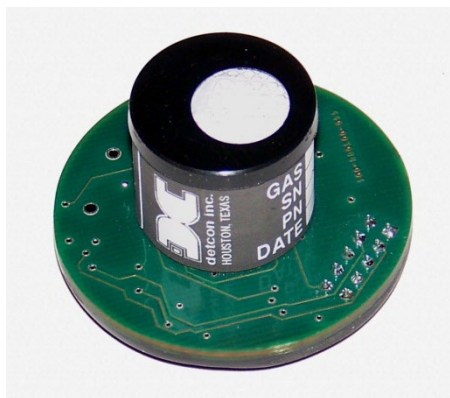

Figure 5 Intelligent Plug-in Sensor Assembly Breakaway

2. Installation

2.1 Guidelines for Safe Use in Potentially Explosive/Hazardous Atmosphere

1. Install sensor only in areas with classifications matching with those described on the approval label. Follow all warnings listed on the label.
2. Ensure that the sensor is properly threaded into a suitable flameproof rated junction box with a downward pointing female 3/4" NPT threaded connection. The sensor should be threaded up at least 5 full turns until tight, with the LED display facing forward (+/- 15°). Minimize use of Teflon Tape, or any type of non-conductive pipe thread coating on the NPT threaded connection.
3. A good ground connection should be verified between the sensor's metal enclosure and the junction box. If a good ground connection is not made, the sensor can be grounded to the junction box using the sensor's external ground lug. Also verify a good ground connection between the junction box and earth ground. Installer shall use ring terminal to make connection to earth ground to be secured by screw and lockwasher on sensor housing. Caution: do not loosen or twist the protective earth conductor. An earth conductor shall be mounted so that it is secured against loosening and twisting.
4. Proper precautions should be taken during installation and maintenance to avoid the build-up of static charge on the plastic components of the sensor. These include the splashguard and splashguard adapter.
5. Do not substitute components that are not authorized by the scope of the safety approval. This may impair the intrinsic safety rating.
6. Do not operate the sensor outside of the stated operating temperature limits.
7. Do not operate the sensor outside the stated operating limits for voltage supply.
8. The sensor power supply common (black wire) must be referenced to the metal enclosure body (ground) during installation.
9. These sensors meet ATEX: EN IEC 60079-0:2018, EN 60079-1:2014, EN 60079-11:2012. IECEx: IEC 60079-0:2017, IEC 60079-1:2014, IEC 60079-11:2011. cCSAus: CSA C22.2 No. 30 & 157, UL 1203 & 913
10. These sensors have a maximum safe location voltage of $U_m=30V$.
11. The flamepath joints are not intended to be repaired if damaged.
12. These sensors pass dielectric strength of 500VRMS between circuit and enclosure for a minimum of 1 minute at a maximum test current of 5mA.
13. Conditions of Acceptability for CSA: All 700 series models must be supplied by a Class 2 or limited-energy source.

2.2 Sensor Placement

Selection of sensor location is critical to the overall safe performance of the product. Six factors play an important role in selection of sensor locations:

- (1) Density of the gas to be detected
- (2) Most probable leak sources within the industrial process
- (3) Ventilation or prevailing wind conditions
- (4) Personnel exposure
- (5) Maintenance access
- (6) Additional placement considerations

Density

Placement of sensors relative to the density of the target gas is such that sensors for the detection of heavier than air gasses should be located within 4 feet of grade as these heavy gasses will tend to settle in low lying areas. For gasses lighter than air, sensor placement should be 4-8 feet above grade in open areas or in pitched areas of enclosed spaces.

Leak Sources

The most probable leak sources within an industrial process include flanges, valves, and tubing connections of the sealed type where seals may either fail or wear. Other leak sources are best determined by facility engineers with experience in similar processes.

Ventilation

Normal ventilation or prevailing wind conditions can dictate efficient location of gas sensors in a manner where the migration of gas clouds is quickly detected.

Personnel Exposure

The undetected migration of gas clouds should not be allowed to approach concentrated personnel areas such as control rooms, maintenance or warehouse buildings. A more general and applicable thought toward selecting sensor location is combining leak source and perimeter protection in the best possible configuration.

Maintenance Access

Consideration should be given to providing easy access for maintenance personnel. Consideration should also be given to the consequences of close proximity to contaminants that may foul the sensor prematurely.

NOTE: All installations of the gas sensor should point straight down (refer to Figure 9). Improper sensor orientation may result in false readings and permanent sensor damage.

Additional Placement Considerations

The sensor should not be positioned where it may be sprayed or coated with surface contaminating substances. Painting sensor assemblies is prohibited.

Although the sensor is designed to be RFI resistant, it should not be mounted in close proximity to high-powered radio transmitters or similar RFI generating equipment.

Mount in an area void of high wind, accumulating dust, rain or splashing from hose spray, direct steam releases, and continuous vibration. If the sensor cannot be mounted away from these conditions then make sure the Teledyne Detcon Harsh Environment Splashguard accessory is used.

Do not mount in locations where temperatures will exceed the operating temperature limits of the sensor. Where direct sunlight leads to exceeding the high temperature-operating limit, use a sunshade to help reduce temperature.

2.3 Sensor Contaminants and Interference

PID VOC and toxic gas sensors will respond to any gas with an ionization potential <math><10.6\text{eV}</math>. This is not a selective measurement technique, and hence can be used to measure a wide range of gases.

Some of the most commonly present gasses that potentially cause PID interference are listed in Table 5 Gas Factor Table (refer to Section 9). The presence of cross-interference gases in an area does not preclude the use of this sensor technology, although it is likely that the sensor will experience false high readings should exposure occur.

Some heavy organic molecules may be polymerized onto, or strongly adhere to, the optical filter of the lamp. When this occurs, the lamp will require cleaning or replacement.

Relative Response Gas Matrix

Table 5 Gas Factor Table shows the response of the PID sensor to a long list of components. It includes the compound name, synonyms/abbreviations, and chemical formula. It also lists the 10.6eV Response Factor (the measure of how strong the signal from the sensor is in reference to Isobutylene gas). Isobutylene gas is the standard reference used with PID sensors, the lower the Response Factor, the stronger the signal.

2.4 Mounting Installation

The PI-700 sensor assembly is designed to be threaded into a $\frac{3}{4}$ " Female NPT fitting of a standard cast metal, Explosion-Proof Enclosure or Junction Box. Thread the sensor up until tight (5 turns is typically expected) and until the display is pointed in the direction that sensor will normally be viewed and accessed.

The PI-700 should be vertically oriented so that the sensor points straight down. The explosion-proof enclosure or junction box would then typically be mounted on a wall or pole. Teledyne Detcon provides a standard selection of junction boxes available as sensor accessories (See Figures 7, 8, and 9 below). Any appropriately rated enclosure with a downward facing $\frac{3}{4}$ " NPT female connection will suffice.

When mounting on a wall, it is recommended to use a 0.25"-0.5" spacer underneath the mounting ears of the Teledyne Detcon standard J-Box to offset the sensor assembly from the wall and create open access around the sensor assembly. Spacing requirements for other junction boxes may vary.

When mounting on a pole, secure the Junction Box to a suitable mounting plate and attach the mounting plate to the pole using U-Bolts. (Pole-Mounting brackets for Teledyne Detcon J-box accessories are available separately.)

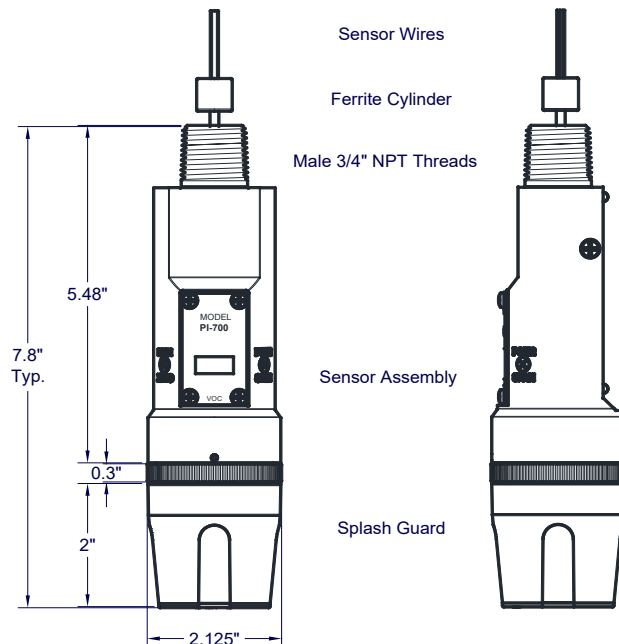

Figure 6 Outline and Mounting Dimensions (Sensor Assembly only)

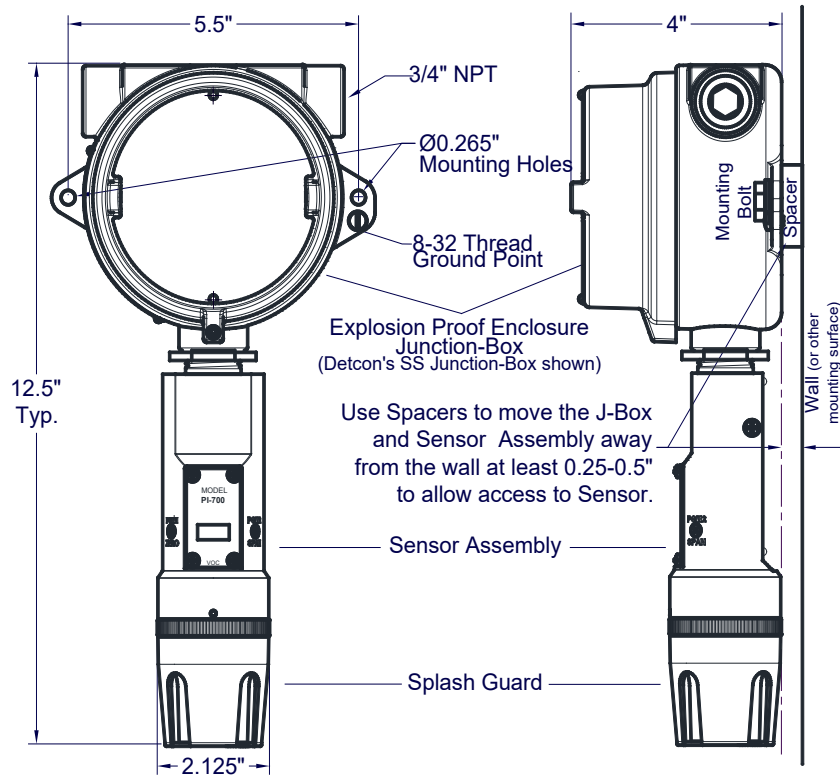

Figure 7 Outline and Mounting Dimensions (Stainless Steel Junction Box)

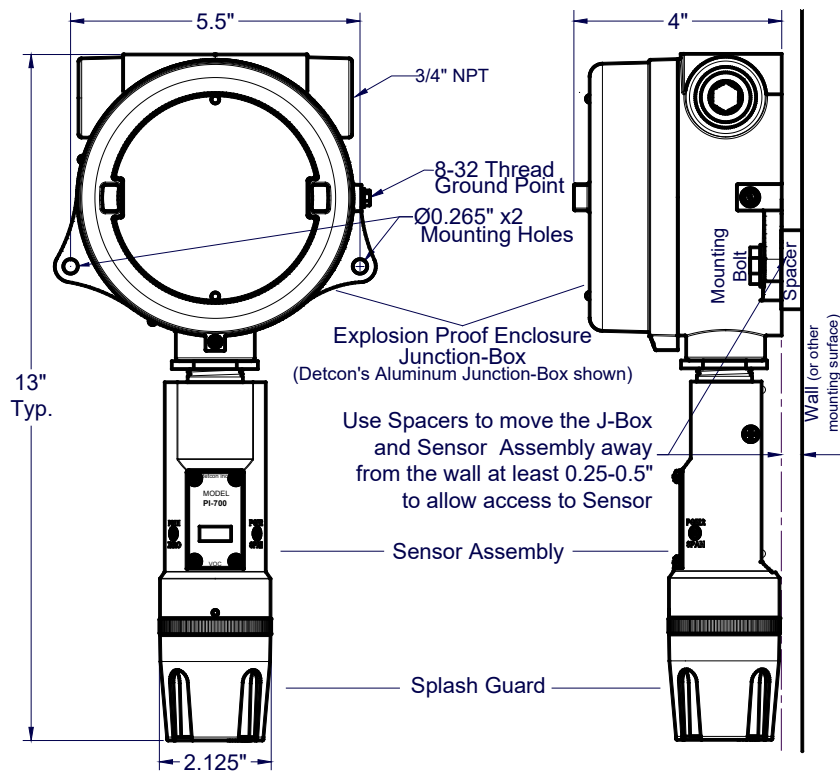

Figure 8 Outline and Mounting Dimensions (Aluminum Junction Box)

2.5 Electrical Installation

The Sensor Assembly should be installed in accordance with local electrical codes. The sensor assemblies are designed for Class I Division 1 Groups A, B, C, D, Class I Zone 1 Group IIC area classifications, and for ATEX & IECEx Zone 1 Groups IIC. Refer to Appendix for full product specifications.

Proper electrical installation of the gas sensor is critical for conformance to Electrical Codes and to avoid damage due to water leakage. Refer to Figure 9 and Figure 10 for proper electrical installation.

NOTE: If a conduit run exits the secondary port, repeat the installation technique shown in Figure 9.

In Figure 9, the drain allows water condensation inside the conduit run to safely drain away from the sensor assembly. The electrical seal fitting is required to meet the National Electrical Code per NEC Article 500-3d (or Canadian Electrical Code Handbook Part 1 Section 18-154). Requirements for locations of electrical seals are covered under NEC Article 501-5. Electrical seals also act as a secondary seal to prevent water from entering the wiring terminal enclosure. However, they are not designed to provide an absolute water-tight seal, especially when used in the vertical orientation.

NOTE: For products utilizing the aluminum junction box option, the conduit seal shall be placed at the entry to the junction box (see Figure 9 as an example). For products utilizing the stainless steel junction box option, the conduit seal shall be placed within 18" of the enclosure. Crouse Hinds type EYS2, EYD2 or equivalent are suitable for this purpose.

NOTE: The Teledyne Detcon Warranty does not cover water damage resulting from water leaking into the enclosure through the conduit connections. Since the electronics are 100% epoxy encapsulated, only the wire terminations can get wet. This could cause abnormal operation and possibly cause corrosion to the terminal connections. However, it would not be expected to cause permanent damage to the sensor.

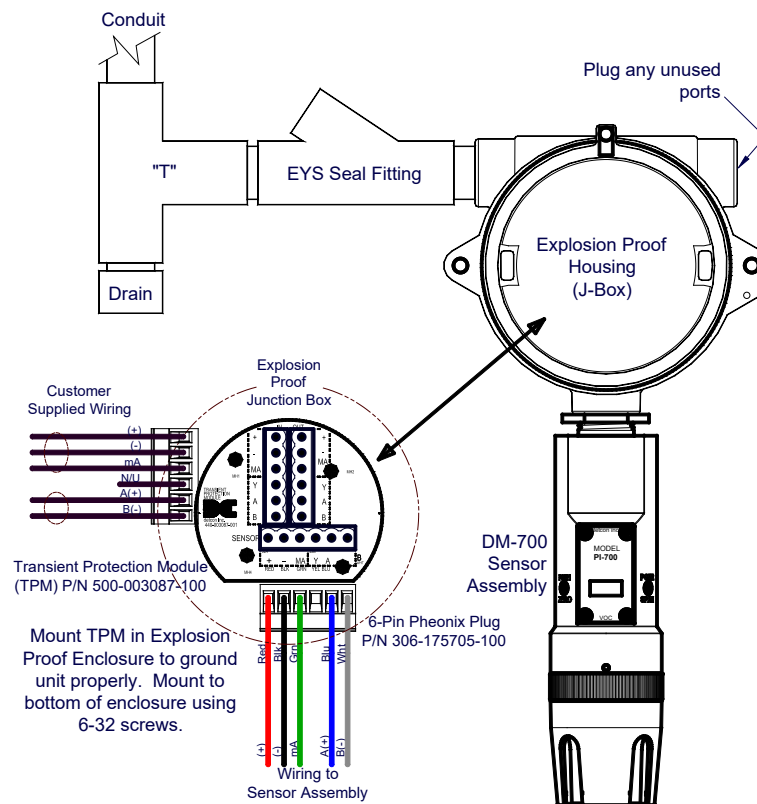

Figure 9 Typical Installation

NOTE: Any unused ports should be blocked with suitable 3/4" male NPT plugs. Teledyne Detcon supplies one 3/4" NPT male plug with their accessory J-box enclosures. If connections are other than 3/4" NPT, use an appropriate male plug of like construction material.

2.6 Field Wiring

Teledyne Detcon Model PI-700 toxic gas sensors assemblies require three conductor connections between power supplies and host electronic controller's 4-20mA output, and two conductor connections for the Modbus™ RS-485 serial interface. Wiring designations are + (DC), – (DC), mA (sensor signal), and Modbus™ RS-485 A (+), and B (-). Maximum wire size for termination in the Teledyne Detcon J-Box accessory is 14 gauge.

Table 1 Wire Gauge vs. Distance

AWG	Wire Dia.	Meters	Feet	Over-Current Protection
22	0.723mm	700	2080	3A
20	0.812mm	1120	3350	5A
18	1.024mm	1750	5250	7A
16	1.291mm	2800	8400	10A
14	1.628mm	4480	13,440	20A

NOTE 1: Wiring table is based on stranded tinned copper wire and is designed to serve as a reference only.

NOTE 2: Shielded cable is required for installations where cable trays or conduit runs include high voltage lines or other possible sources of induced interference. Separate conduit runs are highly recommended in these cases.

NOTE 3: The supply of power should be from an isolated source with over-current protection as stipulated in table.

Terminal Connections



CAUTION: Do not apply System power to the sensor until all wiring is properly terminated. Refer to Section 2.7 Initial Start Up



CAUTION: Do not apply power to the sensor assembly in a hazardous area unless the junction box cover is tight and all electrical seals have been installed

A good ground connection should be verified between the sensor and the junction box. If a good ground connection is not made, the sensor can be grounded to the junction box using the external ground lug. Also verify a good ground connection between the junction box and earth ground.

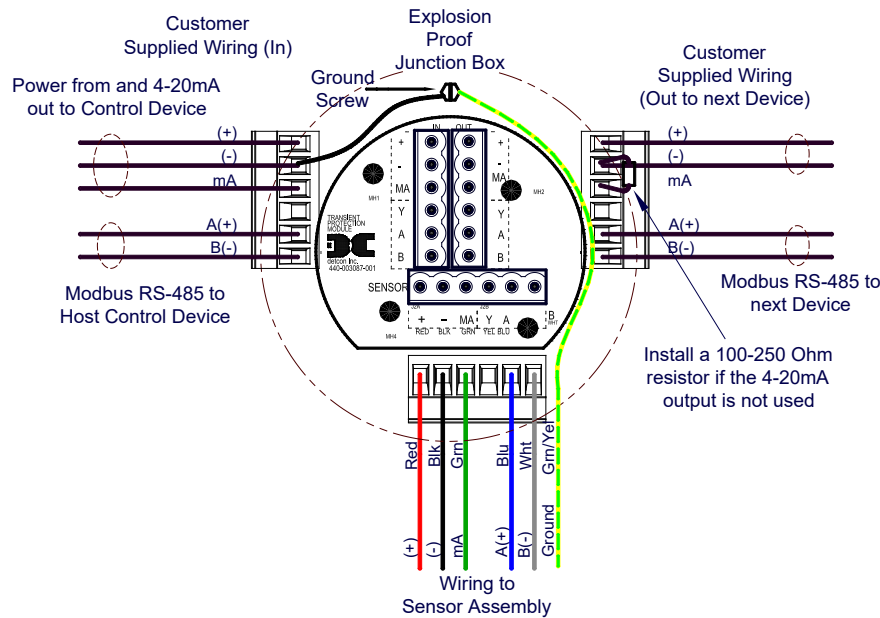

Figure 10 Sensor Wire Connections

- a) Remove the junction box cover. Identify the terminal blocks for customer wire connections.
- b) Observing correct polarity, terminate the 3-conductor 4-20mA field wiring (+, -, mA) to the sensor assembly wiring in accordance with the detail shown in Figure 10. If the 4-20mA output is not used, install a 100-250Ω resistor between the mA and (-) terminals on the Transient Protection Module.



CAUTION: The sensor power supply common (black wire) must be referenced to the metal enclosure body (Ground) during installation.

NOTE: If the 4-20mA output is not being used, a 100-250Ω resistor *must* be installed between the mA and (-) terminals on the Transient Protection Module to ensure proper sensor operation.

- c) If applicable, terminate the RS-485 serial wiring as shown in Figure 10. Use the second plug (Out) as termination point on the customer side to facilitate a continuous RS-485 serial loop

The RS-485 (if applicable) requires 24 gauge, two conductor, shielded, twisted pair cable between the sensor and host. General Cable Commodore part number ZO16P0022189 is recommended.

NOTE: Install a 120-ohm resistor across A & B terminals on the last sensor in the serial loop.

- d) Trim all exposed wire leads if they are not permanently landed in the terminal block.
- e) Replace the junction box cover.

2.7 Initial Start Up



CAUTION: Do not apply power to the sensor assembly in a hazardous area unless the junction box cover is tight and all electrical seals have been installed

Upon completion of all mechanical mounting and termination of all field wiring, apply system power in the range of 11.5-30VDC (24VDC typical) and observe the following normal conditions:

- a) PI-700 display reads close to “0”, and no fault messages are flashing.
- b) A temporary upscale or downscale reading may occur as the sensor stabilizes. This upscale reading will typically decrease to near “0”ppm within 1-2 minutes of power-up, assuming there is no gas in the area of the sensor. In some extreme cases, the sensor may require up to 5 minutes before the lamp ignites and becomes operational.

NOTE: The 4-20mA signal is held constant at 4mA for the first two minutes after power up.

Initial Operational Tests

After a warm up period of 1 hour (or when zero has stabilized), the sensor should be checked to verify sensitivity to the specific target gas of the application (not just Isobutylene span gas).

NOTE: A secondary filter accessory, built into the splashguard adapter, is used with the Model 700 PID sensors (Figure 14). This multi-stage filter is designed to prevent heavy and complex airborne VOC molecules from contacting the PID sensor and causing surface contamination and subsequent reading drift. When used effectively, it may extend the time between required sensor cleaning and / or sensor replacement. Its use is limited to application cases where the target gas(s) are moderate to small VOC molecules (i.e. benzene and smaller molecular weights). Before installing, it must be verified that the filter does not inhibit response to the target gas being monitored. Do not use this filter if the target gas response is inhibited. The service life of the filter may vary depending on the application; however, it is advised to change it out at least on a 18-24 month cycle.

Material Requirements

- Teledyne Detcon PN 613-120000-700 700 Series Splash Guard with integral Cal Port –OR–
 - Teledyne Detcon PN 943-000006-132 Threaded Calibration Adapter
 - Teledyne Detcon Span Gas (See Teledyne Detcon for Ordering Information). Recommended span gas is 50% of range with Isobutylene in air or N₂ balance.
 - Teledyne Detcon P/N 985-241100-321 In-Line Humidifying Tube 24”
- a) Attach the calibration adapter to the threaded sensor housing or connect tubing to integral cal port. Apply the test gas at a controlled flow rate of 200 – 500cc/min using the in-line humidifying tube, (200cc/min is the recommended flow). Observe that the ITM display increases to a level near that of the applied calibration gas value.
- b) Remove test gas and observe that the ITM display decreases to “0”.

Initial operational tests are complete. PI-700 VOC gas sensors are factory calibrated prior to shipment, and should not require significant adjustment on start up. However, it is recommended that a complete calibration test and adjustment be performed 16 to 24 hours after power-up. Refer to zero and span calibration instructions in Section 3.4.

3. Operation

3.1 Programming Magnet Operating Instructions

The Operator Interface of the Model 700 Series gas sensors is accomplished via two internal magnetic switches located to either side of the LED display (see Figure 12). The two switches, labeled “PGM1” and “PGM2”, allow for complete calibration and configuration, thereby eliminating the need for area de-classification or the use of hot permits.



Figure 11 Magnetic Programming Tool

The magnetic programming tool (Figure 11) is used to operate the magnetic switches. Switch action is defined as momentary contact, 3-second hold, and 10-second hold. (Hold times are defined as the time from the point when the arrow-prompt “◀” appears.) For momentary contact use, the programming magnet is briefly held over a switch location. For 3-second hold, the programming magnet is held in place over the switch location for three seconds. For 10-second hold, the programming magnet is held in place over the switch location for 10 seconds. The 3 and 10 second holds are generally used to enter calibration/program menus and save new data. The momentary contact is generally used to move between menu items and to modify set-point values. Arrows (“◀” and “▶”) are used on the LED display to indicate when the magnetic switches are activated. The location of “PGM1” and “PGM2” are shown in Figure 12.

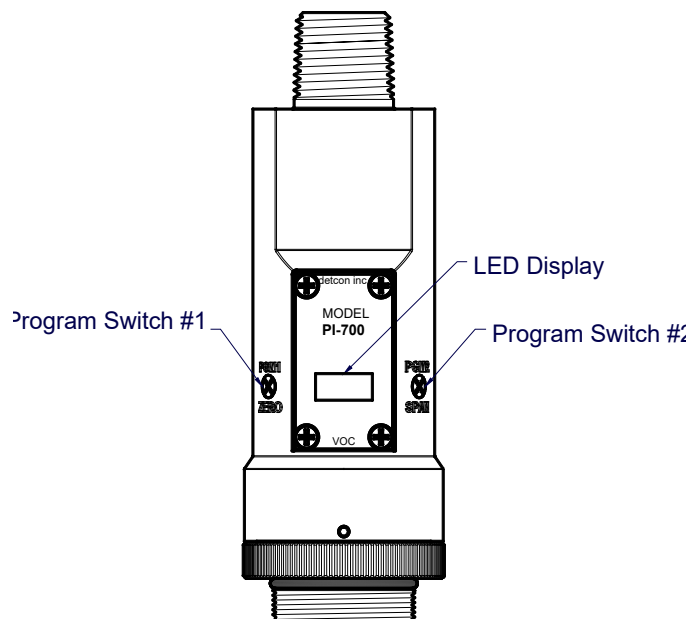

Figure 12 Magnetic Programming Switches

NOTE: While in the Program Mode, if there is no magnetic switch interaction after 4 consecutive menu scrolls, the sensor will automatically revert to normal operating condition. While changing values inside menu items, **if there is no magnet activity after 3-4 seconds the sensor will revert to the menu scroll.** (Exception to this is with “Signal Output Check” mode.)

3.2 Operator Interface

The operating interface is menu-driven via the two magnetic program switches located under the target marks of the sensor housing. The two switches are referred to as “PGM1” and “PGM2”. The menu list consists of three major items that include sub-menus as indicated below. (Refer to the complete Software Flow Chart.)

Normal Operation

Current Reading and Gas Type/Fault Status

Calibration Mode

AutoZero

AutoSpan

Program Mode

View Sensor Status

Sensor Model Type

Current Software Version

Gas Type

Range of Detection

Serial ID address

AutoSpan Level

Days Since Last AutoSpan

Remaining Sensor Life

Gas Factor

Zero Offset

mA Output

Input Voltage Supply

Sensor Temperature

Gain Setting

Raw Counts

Set AutoSpan Level

Set Serial ID

Set Range

Set Gas Factor

Set Zero Offset

Signal Output Check

Restore Default Settings

Software Flowchart

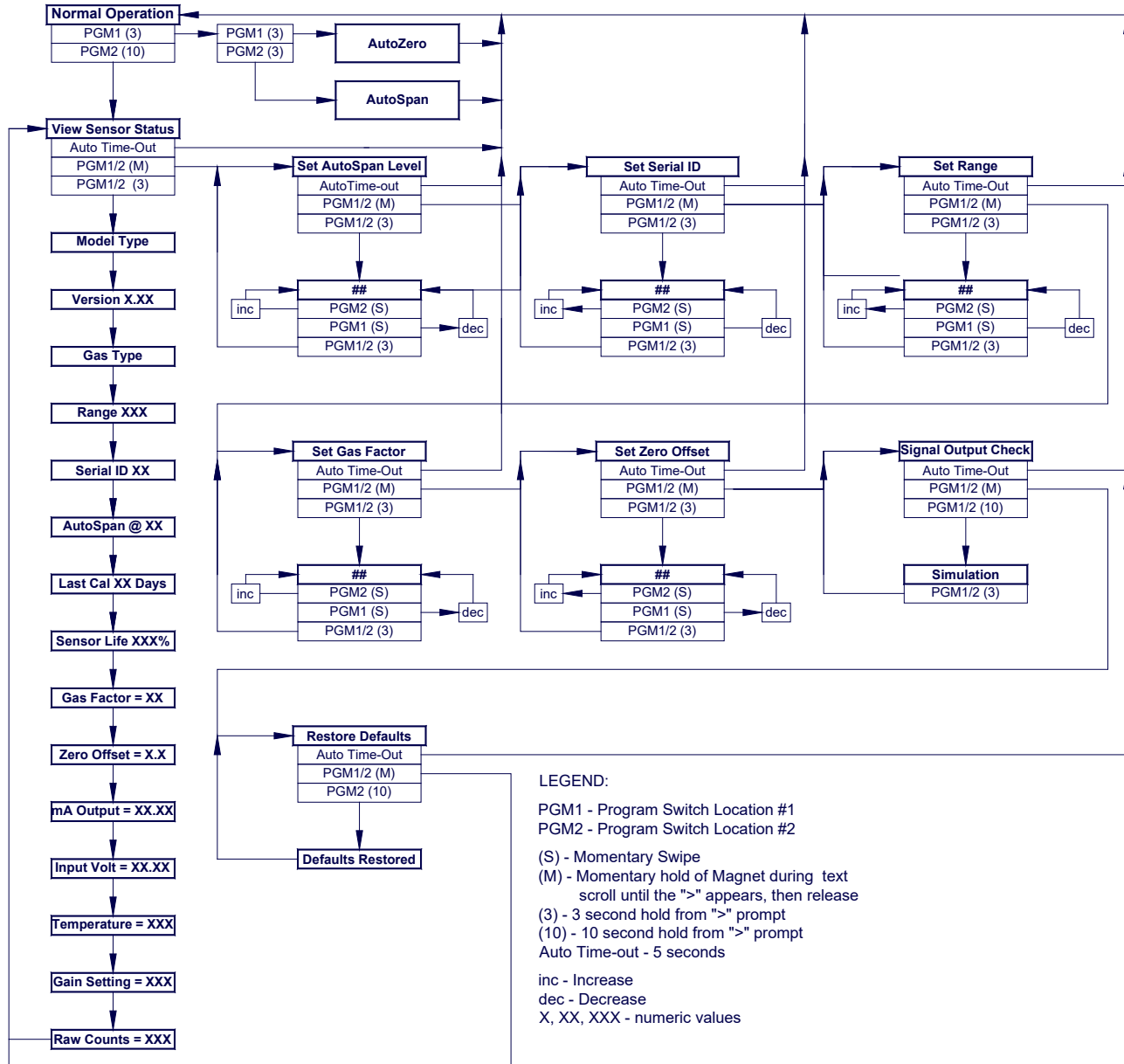

3.3 Normal Operation

In normal operation, the ITM Display continuously shows the current sensor reading, which will normally appear as “ 0 ”. Once every 60 seconds the LED display will flash the sensor’s measurement units and gas type (i.e. ppm VOC). If the sensor is actively experiencing any diagnostic faults, a “Fault Detected” message will scroll across the display on the ITM display once every minute instead of the units of measure and the gas type. At any time, while the sensor is in “Fault Detected” mode, PGM1 or PGM2 can be swiped to prompt the sensor to display a list of the active faults.

In normal operation, the 4-20mA current output linearity corresponds with the full-scale range. The RS-485 Modbus™ serial output provides the current gas reading and complete fault status on a continuous basis when polled by the master device.

3.4 Calibration Mode

3.4.1 AutoZero

The AutoZero function is used to zero the sensor. Local ambient air can be used to zero calibrate a VOC gas sensor as long as it can be confirmed that it contains no target or interference gasses. If this cannot be confirmed then a zero air or N₂ cylinder should be used.

Material Requirements:

- Teledyne Detcon PN 327-000000-000 MicroSafe™ Programming Magnet
- Teledyne Detcon PN 613-120000-700 700 Series Splash Guard with integral Cal Port and Calibration Wind Guard (P/N 943-000000-000) -OR-
- Teledyne Detcon PN 943-000006-132 Threaded Calibration Adapter
- Teledyne Detcon PN 942-001123-000 Zero Air cal gas (or use ambient air if no target gas is present).
- Teledyne Detcon P/N 942-640023-100 Nitrogen 99.99%
- Teledyne Detcon P/N 985-241100-321 In-Line Humidifying Tube 24”

NOTE: The Calibration Wind Guard must be used when the Splashguard Adapter with integral Cal Port is used. Failure to use the Calibration Wind Guard may result in an inaccurate AutoZero calibration.

- a) For VOC sensors, if the ambient air is known to contain no target gas content, then it can be used for zero calibration. If a zero gas or N₂ cal cylinder is going to be used, be sure to use in-line humidifying tube to present cal gas with correct ambient humidity level. Attach the calibration adapter and set flow rate of 200-500cc/min and let sensor purge for 1-2 minutes before executing the AutoZero.
- b) From Normal Operation, enter Calibration Mode by holding the programming magnet over PGM1 for 3 seconds. Note, the “◀” prompt will show that the magnetic switch is activated during the 3 second hold period. The display will then scroll “PGM1=AutoZero ...PGM2=AutoSpan”. Hold the programming magnet over PGM1 for 3 seconds once the “▶” prompt appears to execute AutoZero (or allow to timeout in 5 seconds if AutoZero is not desired).

NOTE: Upon entering Calibration Mode, the 4-20mA signal drops to 2mA and is held at this level until the program returns to normal operation. Modbus™ Status Register bit 14 is also set to signify when the sensor is in-calibration mode.

- c) The ITM will display the following sequence of text messages as it proceeds through the AutoZero sequence:

Zero Cal . . . Setting Zero . . . Zero Saved

- d) Remove the zero gas and calibration adapter, if applicable.

3.4.2 AutoSpan

The AutoSpan function is used to span calibrate the sensor. Unless otherwise specified, span adjustment is recommended at 50% of range. This function is called “AUTO SPAN”.

NOTE: Before performing AutoSpan Calibration, verify that the AutoSpan level matches the span calibration gas concentration as described in Section 3.5.2.

Material Requirements:

- Teledyne Detcon PN 327-000000-000 MicroSafe™ Programming Magnet
- Teledyne Detcon PN 613-120000-700 700 Series Splash Guard with integral Cal Port and Calibration Wind Guard (P/N 943-000000-000) - OR –
- Teledyne Detcon PN 943-000006-132 Threaded Calibration Adapter
- Target Span Gas (See Teledyne Detcon for Ordering Information) representing the target gas (with air or N₂ balance) between 10% and 90% of the full-scale range – OR –
- Isobutylene Span Gas. Recommended span gas is 50% of range with Isobutylene in air or N₂ balance

- Teledyne Detcon P/N 985-241100-321 In-Line Humidifying Tube 24”

NOTE 1: Contact Teledyne Detcon for Ordering Information on Span Gas cylinders.

NOTE 2: For span, an Isobutylene gas concentration of 50% of range is normally recommended (see Note 4). This should be supplied at a controlled flow rate of 500cc/min using the in-line humidifying tube. Other concentrations can be used if they fall within allowable levels of 5% to 100% of range.

NOTE 3: If Isobutylene is used as span gas, the correct Gas Factor must be used.

NOTE 4: It is strongly recommended to use the target VOC gas to calibrate for span. This eliminates any possibility that Isobutylene cross-calibration is not accurate. Cross-calibration by use of other gasses should be confirmed by Teledyne Detcon or at a minimum executed relative to the information provided in Table 5.

NOTE 5: The Calibration Wind Guard must be used when the Splashguard Adapter with integral Cal Port is used. Failure to use the Calibration Wind Guard may result in an inaccurate AutoSpan calibration.



CAUTION: Verification that the calibration gas level setting matches the calibration span gas concentration is required before executing “AutoSpan” calibration. These two numbers must be equal.

AutoSpan consists of entering Calibration Mode and following the menu-displayed instructions. The display will ask for the application of span gas in a specific concentration. The applied gas concentration must be equal to the calibration gas level setting. The factory default setting and recommendation for span gas concentration is 50% of range. If a span gas containing the recommended concentration is not available, other concentrations may be used as long as they fall between 5% and 100% of range. However, any alternate span gas concentration value must be programmed via the “Set AutoSpan Level” menu before proceeding with AutoSpan calibration. Follow the instructions “a” through “e” below for AutoSpan calibration.

- Verify that the AutoSpan Level is equal to the Calibration Span Gas Concentration. (Refer to View Sensor Status in Section 3.5.1.) If the AutoSpan Level is not equal to the Calibration span gas concentration, adjust the AutoSpan Level as instructed in Section 3.5.2.
- From Normal Operation, enter Calibration Mode by holding the programming magnet over PGM1 for 3 seconds. Note, the “◀” prompt will show that the magnetic switch is activated during the 3 second hold period. The display will then scroll “PGM1=AutoZero . . . PGM2=AutoSpan”. Hold the programming magnet over PGM2 for 3 seconds to execute AutoSpan (or allow to timeout in 5 seconds if AutoSpan is not intended). The ITM will then scroll “Apply XX ppm Gas”.

NOTE: Upon entering Calibration Mode, the 4-20mA signal drops to 2mA and is held at this level until the program returns to normal operation. Modbus™ Status Register bit 14 is also set to signify when the sensor is in-calibration mode.

- Apply the span calibration test gas for VOC gas sensors at a flow rate of 200-500cc/min using the in-line humidifying tube (200cc/min is recommended). As the sensor signal begins to increase the display will switch to flashing “XX” reading as the ITM shows the sensor’s “as found” response to the span gas presented. If it fails to meet the minimum in-range signal change criteria within 2½ minutes, the display will report “Range Fault” twice and the ITM will return to normal operation, aborting the AutoSpan sequence. The ITM will continue to report a “Range Fault” and will not clear the fault until a successful AutoSpan is completed.

Assuming acceptable sensor signal change, after 1 minute the reading will auto-adjust to the programmed AutoSpan level. During the next 30 seconds, the AutoSpan sequence checks the sensor for acceptable reading stability. If the sensor fails the stability check, the reading is re-adjusted back to the AutoSpan level and the cycle repeats until the stability check is passed. Up to three additional 30-second stability check periods are allowed before the unit reports a “Stability Fault” twice and the ITM will return to normal operation, aborting the AutoSpan sequence. The ITM will continue to report a “Stability Fault” and will not clear the fault until a successful AutoSpan is completed.

If the sensor passes the stability check, the ITM reports a series of messages:

“Span OK”

“Sensor Life XXX%”

“Remove Span Gas”

- d) Remove the span gas source and calibration adapter. The ITM will report a live reading as it clears toward “0”. When the reading clears below 10% of range, the ITM will display **“Span Complete”** and will revert to normal operation. If the sensor fails to clear to less than 10% in less than 5 minutes, a **“Clearing Fault”** will be reported twice and the ITM will return to normal operation, aborting the AutoSpan sequence. The ITM will continue to report a **“Clearing Fault”** and will not clear the fault until a successful AutoSpan is completed.

NOTE: When calibrating sensors where there are high levels of VOC gases in the ambient background, use Zero Air or N₂ to assist clearing to <10% of range.

- e) The AutoSpan calibration is complete.

NOTE 1: Upon entering the calibration menu, the 4-20mA signal drops to 2mA and is held at this level until the program returns to normal operation.

NOTE 2: If the sensor fails the minimum signal change criteria, a **“Range Fault”** will be declared and a **“Fault Detected”** message will be displayed alternately with the sensor’s current reading. The 4-20mA output will be taken to 0mA and the ‘Range Fault’ fault bit will be set on the Modbus™ output.

NOTE 3: If the sensor fails the stability criteria, a **“Stability Fault”** will be declared and a **“Fault Detected”** message will be displayed alternately with the sensor’s current reading. The 4-20mA output will be taken to 0mA and the ‘Stability Fault’ fault bit will be set on the Modbus™ output.

NOTE 4: If the sensor fails the clearing time criteria, a **“Clearing Fault”** will be declared and a **“Fault Detected”** message will be displayed alternately with the sensor’s current reading. The 4-20mA output will be taken to 0mA and the ‘Clearing Fault’ fault bit will be set on the Modbus™ output.

3.5 Program Mode

Program Mode provides a **“View Sensor Status”** menu to check operational and configuration parameters. Program Mode provides for adjustment of the AutoSpan Level, Serial ID, Set Range, Set Gas Factor, and Set Zero Offset. Additionally, Program Mode includes the diagnostic function **“Signal Output Check”** and **“Restore Factory Defaults”**. The Program Mode menu items appear in the order presented below:

- View Sensor Status
- Set AutoSpan Level
- Set Serial ID
- Set Range
- Set Gas Factor
- Set Zero Offset
- Signal Output Check
- Restore Default Settings

3.5.1 Navigating Program Mode

From Normal Operation, enter Program Mode by holding the magnet over PGM2 for 10 seconds. Note, the “◀” prompt will show that the magnetic switch is activated during the 10 second hold period. The ITM will enter Program Mode and the display will display the first menu item **“View Sensor Status”**. To advance to the next menu item, hold the magnet over PGM1 or PGM2 while the current menu item’s text is scrolling. At the conclusion of the text scroll the arrow prompt (“◀” for PGM2 or “▶” for PGM1) will appear, immediately remove the magnet. The ITM will advance to the next menu item. Repeat this process until the desired menu item is displayed. Note, PGM1 moves the menu items from right to left and PGM2 moves the menu items from left to right.

To enter a menu item, hold the magnet over PGM1 or PGM2 while the menu item is scrolling. At the conclusion of the text scroll the “◀” prompt (“◀” for PGM2 or “▶” for PGM1) will appear, continue to hold the magnet

over PGM1 or PGM2 for an additional 3-4 seconds to enter the selected menu item. If there is no magnet activity while the menu item text is scrolling (typically 4 repeated text scrolls), the ITM will automatically revert to Normal Operation.

3.5.2 View Sensor Status

View Sensor Status displays all current configuration and operational parameters including: sensor type, software version number, gas type, detection range, AutoSpan level, days since last AutoSpan, estimated remaining sensor life, gas factor, zero offset, mA output, input voltage, sensor ambient temperature, gain setting, and the sensor's raw counts.

From the **View Sensor Status** text scroll, hold the magnet over PGM1 or PGM2 until the “◀” prompt appears and continue to hold the magnet in place for an additional 3-4 seconds (until the display starts to scroll “Status Is”). The display will scroll the complete list of sensor status parameters sequentially:

Sensor Model Type

The menu item appears as: “Model PI-700”

Current Software Version

The menu item appears as: “Version 1.XX”

Gas Type

The menu item appears as: “ Gas Type = VOC”

Range of Detection.

The menu item appears as: “Range XXX”

Serial ID address.

The menu item appears as: “Serial ID XX”

AutoSpan Level.

The menu item appears as: “AutoSpan Level XX”

Days Since Last AutoSpan.

The menu items appears as: “Last Cal XX days”

Remaining Sensor Life.

The menu item appears as: “Sensor Life 100%”

Gas Factor

The menu item appears as: “Gas Factor X.X”

Zero Offset

The menu item appears as: “Zero Offset X.X”

mA Output

The menu item appears as: “mA Output XX.XX”

Input Voltage Supply

The menu item appears as: “Voltage XX.X VDC”

Sensor Temperature

The menu item appears as: “Temp XX C”

Gain Setting

The menu item appears as: “Gain XX”

Raw Counts

The menu item appears as: “Counts XXXX”

When the status list sequence is complete, the ITM will revert to the “View Sensor Status” text scroll. The user can either: 1) review list again by executing another 3-4 second hold, 2) move to another menu item by executing a momentary hold over PGM1 or PGM2, or 3) return to Normal Operation via automatic timeout of about 15 seconds (the display will scroll “View Sensor Status” 4 times and then return to Normal Operation).

3.5.3 Set AutoSpan Level

Set AutoSpan Level is used to set the span gas concentration level that is being used to calibrate the sensor. This level is adjustable from 1% to 99% of range depending on the range of the sensor (see Table 2) . The current setting can be viewed in View Program Status.

Table 2 Maximum and Minimum AutoSpan Settings

Sensor Full Scale Range	Minimum AutoSpan Level	Maximum AutoSpan Level	Adjustment Increment
1.00	0.01	0.99	0.01
2.00	0.01	1.99	0.01
3.00	0.01	2.99	0.01
4.00	0.01	3.99	0.01
5.00	0.01	4.99	0.01
6.00	0.01	5.99	0.01
7.00	0.01	6.99	0.01
8.00	0.01	7.99	0.01
9.00	0.01	8.99	0.01
10.0	1.0	9.9	0.1
11.0	1.0	10.9	0.1
12.0	1.0	11.9	0.1
13.0	1.0	12.9	0.1
14.0	1.0	13.9	0.1
15.0	1.0	14.9	0.1
16.0	1.0	15.9	0.1
17.0	1.0	16.9	0.1
18.0	1.0	17.9	0.1
19.0	1.0	18.9	0.1
20.0	1.0	19.9	0.1
21.0	1.0	20.9	0.1
22.0	1.0	21.9	0.1
23.0	1.0	22.9	0.1
24.0	1.0	23.9	0.1
25.0	1.0	24.9	0.1
30	1	25	Note 1
35	1	30	Note 1
40	1	35	Note 1
45	1	40	Note 1
50	1	45	Note 1
55	1	50	Note 1
60	1	55	Note 1
65	1	60	Note 1
70	1	65	Note 1
75	1	70	Note 1
80	1	75	Note 1
85	1	80	Note 1
90	1	85	Note 1

Sensor Full Scale Range	Minimum AutoSpan Level	Maximum AutoSpan Level	Adjustment Increment
95	1	90	Note 1
100	1	95	Note 1
150	1	100	Note 1
200	1	150	Note 1
250	1	200	Note 1
300	1	250	Note 1
350	1	300	Note 1
400	1	350	Note 1
450	1	400	Note 1
500	1	450	Note 1
550	1	500	Note 1
600	1	550	Note 1
650	1	600	Note 1
700	1	650	Note 1
750	1	700	Note 1
800	1	750	Note 1
850	1	800	Note 1
900	1	850	Note 1
950	1	900	Note 1
1000	1	950	Note 1
1500	1	1000	Note 1
2000	1	1500	Note 1
2500	1	2000	Note 1
3000	1	2500	Note 1
3500	1	3000	Note 1
4000	1	3500	Note 1
4500	1	4000	Note 1
5000	1	4500	Note 1
5500	1	5000	Note 1
6000	1	5500	Note 1
6500	1	6000	Note 1
7000	1	6500	Note 1
7500	1	7000	Note 1
8000	1	7500	Note 1
8500	1	8000	Note 1
9000	1	8500	Note 1
9500	1	9000	Note 1
10000	1	9500	Note 1

Note 1: When the AutoSpan value is between 1 and 25, the adjustment increment is 1

When the AutoSpan value is between 26 and 100, the adjustment increment is 5

When the AutoSpan value is between 101 and 1000, the adjustment increment is 50

When the AutoSpan value is between 1001 and 10000, the adjustment increment is 500

The menu item appears as: **“Set AutoSpan Level”**.

From the **Set AutoSpan Level** text scroll, hold the magnet over PGM1 or PGM2 until the “◀” prompt appears and continue to hold the magnet in place for an additional 3-4 seconds (until the display starts to scroll “Set Level”). The display will switch to “XX” (where XX is the current gas level). Swipe the magnet momentarily over PGM2 to increase or PGM1 to decrease the AutoSpan Level until the correct level is displayed. When the correct level is achieved, hold the magnet over PGM1 or PGM2 for 3-4 seconds to accept the new value. The display will scroll “Level Saved”, and revert to “Set AutoSpan Level” text scroll.

Move to another menu item by executing a momentary hold, or return to Normal Operation via automatic timeout of about 15 seconds (the display will scroll “Set AutoSpan Level” 4 times and then return to Normal Operation).

3.5.4 Set Serial ID

Teledyne Detcon Model PI-700 sensors can be polled serially via RS-485 Modbus™ RTU. Refer to Section 4.0 for details on using the Modbus™ output feature.

Set Serial ID is used to set the Modbus™ serial ID address. It is adjustable from 01 to 256 in hexadecimal format (01-FF hex). The current serial ID can be viewed in View Sensor Status using the instruction given in Section 3.5.1 View Sensor Status.

The menu item appears as: “**Set Serial ID**”.

From the “**Set Serial ID**” text scroll, hold the programming magnet over PGM1 or PGM2 until the “◀” prompt appears and continue to hold the magnet in place for an additional 3-4 seconds (until the display starts to scroll “Set ID”). The display will then switch to “XX “ (where XX is the current ID address). Swipe the magnet momentarily over PGM2 to increase or PGM1 to decrease the hexadecimal number until the desired ID is displayed. Hold the magnet over PGM1 or PGM2 for 3-4 seconds to accept the new value. The display will scroll “ID Saved”, and revert to “Set Serial ID” text scroll.

Move to another menu item by executing a momentary hold, or, return to Normal Operation via automatic timeout of about 15 seconds (the display will scroll “Set Serial ID” 5 times and then return to Normal Operation).

3.5.5 Set Range

The full-scale range of a PI-700 sensor is determined at the time of order. The Intelligent Plug-in Sensor is factory calibrated for this range. However, if the application requirements change and the user needs to alter the original range, the “Set Range” function can be used to make field adjustments.

The currently selected full-scale range is displayed in the “**View Sensor Status**” menu. The factory calibrated full-scale range is printed on the Intelligent Plug-in Sensor Label. When a new range is selected the 4-20mA and Modbus™ outputs will automatically be rescaled, and the span gas level will default to 50% of the new range.

The menu item appears as: “**Set Range**”

From the “**Set Range**” text scroll, hold the programming magnet over PGM1 or PGM2 until the “◀” prompt appears and continue to hold the magnet in place for an additional 3-4 seconds (until the display starts to scroll “Set Range”). The display will then switch to “XXX“(where XXX is the current Range). Swipe the magnet momentarily over PGM2 to increase or PGM1 to decrease the range Level until the desired range is displayed. Hold the magnet over PGM1 or PGM2 for 3 seconds to accept the new value. The display will scroll “Range Saved”, and revert to “Set Range” text scroll.

Selectable ranges are:

1, 2, 3, 4, 5, 6, 7, 8, 9, 10, 15, 20 – Normal ranges for Low Range Sensors.

25, 30, 35, 40, 45, 50, 55, 60, 65, 70, 75, 80, 85, 90, 100, 150, 200, 250, 300, 350, 400, 450, 500, 600, 700, 800, 900, 1000, 2000, 3000, 4000, 5000 – Normal ranges for High Range Sensors.

The PI-700 ITM output range can be changed from the plug-in intelligent PID sensor range, but only within the following limitations: The range can be lowered by a factor of 4, or increased by a factor of 4. It is possible, but not advisable, to take a sensor outside the normal ranges for the sensor. Taking a sensor out of the normal range limits for that sensor may give unreliable, inconsistent results, and should be avoided.

Move to another menu item by executing a momentary hold, or, return to Normal Operation via automatic timeout of about 15 seconds (the display will scroll “Set Range” 4 times and then return to Normal Operation).

NOTE 1: The sensor should be re-calibrated after any change is made to the sensor range. AutoSpan and AutoZero should be re-established.

NOTE 2: When a new plug-in sensor is installed, the ITM will automatically default to the range of the plug-in sensor.

3.5.6 Set Gas Factor

All span calibrations are recommended to be done with a calibration standard consisting of Isobutylene in air background. If the target gas is not Isobutylene the correct Gas Factor will need to be set for correct operation. Refer to Table 5 for the correct Gas Factor for the target gas. The current Gas Factor is displayed in the “**View Sensor Status**” menu.

The menu item appears as: “**Set Gas Factor**”

From the **Set Gas Factor** text scroll, hold the magnet over PGM1 or PGM2 until the “◀” prompt appears and continue to hold the magnet in place for an additional 3-4 seconds (until the display starts to scroll “Set Factor”). The display will then switch to “X.XX” (where X.XX is the current gas factor). Swipe the magnet momentarily over PGM2 to increase or PGM1 to decrease the gas factor level until the correct value is displayed. Hold the magnet over PGM1 or PGM2 for 3 seconds to accept the new value. The display will scroll “Factor Saved”, and revert to “Set Gas Factor” text scroll.

Move to another menu item by executing a momentary hold, or, return to Normal Operation via automatic timeout of about 15 seconds (the display will scroll “Set Gas Factor” 4 times and then return to Normal Operation).

3.5.7 Set Zero Offset

If it is determined that there is a constant but negligible amount of residual active VOC gases in the background air, the Zero Offset feature can optionally be used to null this reading out.

To set the “**Zero Offset**” of the sensor, observe the sensor’s concentration reading after a ‘true’ zero air calibration procedure. This reading represents the background ambient VOC contribution to the sensors actual zero set point. Record this reading to set the Zero Offset.

The menu item appears as: “**Set Zero Offset**”

From the “**Set Zero Offset**” text scroll, hold the programming magnet over PGM1 or PGM2 until the “◀” prompt appears and then hold continue to hold the magnet in place for an additional 3-4 seconds (until the display starts to scroll “Set Zero Offset”). The display will then switch to “X.X” (where X.X is the current offset). Swipe the magnet momentarily over PGM2 to increase or PGM1 to decrease the number until the desired zero offset is displayed. Hold the magnet over PGM1 or PGM2 for 3-4 seconds to accept the new value. The display will scroll “ID Saved”, and revert to “Set Zero Offset” text scroll.

Move to another menu item by executing a momentary hold, or, return to Normal Operation via automatic timeout of about 15 seconds (the display will scroll “Set Zero Offset” 5 times and then return to Normal Operation).

If performed correctly the sensor should read 0.0 after returning to normal operation.

3.5.8 Signal Output Check

Signal Output Check provides a simulated 4-20mA output and RS-485 Modbus™ output. This simulation allows the user to conveniently perform a functional system check of their entire safety system. This signal output simulation also aids the user in performing troubleshooting of signal wiring problems.

The menu item appears as: “**Signal Output Check**”.

From the “**Signal Output Check**” text scroll, hold the magnet over PGM1 or PGM2 until the “◀” prompt appears and then hold continuously for an additional 10 seconds. Once initiated, the display will scroll “**Simulation Active**” until the function is stopped. During simulation mode, the 4-20mA value will be increased from 4.0mA to 20.0mA (in 1% of range increments at about a 1 second update rate) and then decreased from 20.0mA to 4.0mA. The same simulation sequence is applied to the Modbus™ output gas reading.

NOTE: Signal Output Check stays active indefinitely until the user stops the function. There is no automatic timeout for this feature.

To end simulation mode, hold magnet over PGM1 or PGM2 for 3 seconds. The display will either move to the prior menu item or move to the next menu item respectively.

Move to another menu item by executing a momentary hold, or, return to Normal Operation via automatic timeout of about 15 seconds.

3.5.9 Restore Factory Defaults

Restore Factory Defaults is used to clear current user configuration and calibration data from memory and revert to factory default values. This may be required if the settings have been configured improperly and a known reference point needs to be re-established to correct the problem.

This menu item appears as: “**Restore Defaults**”.

NOTE: Restoring factory defaults should only be used when absolutely necessary. All previously existing configuration inputs will have to be re-entered if this function is executed. A full 10-second magnet hold on PGM 2 is required to execute this function.

From the “**Restore Defaults**” text scroll, hold the programming magnet over PGM2 until the “◀” prompt appears and continue to hold 10 seconds. The display will scroll “**Restoring Defaults**”, followed by “**New ECS Connected**”, and “**Range XX**” where XX is the default range of the intelligent plug-in sensor.

Move to another menu item by executing a momentary hold, or, return to Normal Operation via automatic timeout of about 15 seconds (the display will scroll “Restore Defaults” 4 times and then return to Normal Operation).

Following the execution of “**Restore Defaults**”, the PI-700 will revert to its factory default settings. The default settings are:

- Serial ID = 01. The Serial ID must be set appropriately by the operator (Section 3.5.3).

NOTE: The following must be performed in order before the sensor can be placed in operation.

- AutoSpan Level = 50% of range. AutoSpan level must be set appropriately by the operator (Section 3.5.2).
- Range: Defaults to range of intelligent plug-in sensor, must be set to the appropriate level by the operator (Section 3.5.4).
- AutoZero: AutoZero settings are lost and user must perform new AutoZero (Section 3.4).
- AutoSpan: AutoSpan Settings are lost and user must perform new AutoSpan (Section 3.4).

3.6 Program Features

Teledyne Detcon PI-700 toxic gas sensors incorporate a comprehensive set of diagnostic features to achieve Fail-Safe Operation. These Operational features and Failsafe Diagnostic features are detailed below.

3.6.1 Operational Features

Over Range

When gas greater than the full-scale range is detected, the ITM display will continuously flash the full-scale reading. This designates an over-range condition. The 4-20mA signal will report a 22mA output during this time.

In-Calibration Status

When the sensor is engaged in AutoZero or AutoSpan calibrations, the 4-20 mA output signal is taken to 2.0 mA and the in-calibration Modbus™ register bit is set. This alerts the user that the ITM is not in an active measurement mode. This feature also allows the user to log the AutoZero and AutoSpan events via their master control system.

Sensor Life

Sensor Life is calculated after each AutoSpan calibration and is reported as an indicator of remaining service life. It is reported in the “View Sensor Status” menu and as a RS-485 Modbus™ register bit. Sensor Life is reported on a scale of 0-100%. When Sensor Life falls below 25%, the sensor cell should be cleaned or replaced within a reasonable maintenance schedule.

Last AutoSpan Date

This reports the number of days that have elapsed since the last successful AutoSpan. This is reported in the View Sensor Status menu. After 180 days, an AutoSpan Fault will be declared.

3.6.2 Fault Diagnostic/Failsafe Features

Fail-Safe/Fault Supervision

Model PI-700 sensors are designed for Fail-Safe operation. If any of the diagnostic faults listed below are active, the ITM Display will scroll the message “Fault Detected” every 1 minute during normal operation. At any time during “Fault Detected” mode, holding the programming magnet over PGM1 or PGM2 for 1 second will display the active fault(s). All active faults are reported sequentially.

Most fault conditions result in failed operation of the sensor. In these cases the 4-20mA signal is dropped to the universal fault level of 0mA. These include the AutoSpan Calibration faults, Sensor Fault, Processor Fault, Memory Fault, Loop Fault, and Input Voltage Fault. The 0mA fault level is not employed for Temperature or AutoSpan Faults. For every diagnostic fault condition the associated RS-485 Modbus™ fault register will be flagged to alert the user digitally.

NOTE: Refer to the Troubleshooting Guide section for guidance on how to address fault conditions.

Range Fault – AutoSpan

If the sensor fails the minimum signal change criteria (Section 3.4.2) during AutoSpan sequence, the “Range Fault” will be declared. A “Range Fault” will cause a “Fault Detected” message to flash intermittently on the ITM display and drop the 4-20mA output to 0mA. The Modbus™ fault register bit for Range Fault will be set and will not clear until the fault condition has been cleared. The sensor should be considered ‘Out-of-Service’ until a successful AutoSpan calibration is performed.

Stability Fault – AutoSpan

If the sensor fails the signal stability criteria (Section 3.4.2) during AutoSpan sequence, the “Stability Fault” will be declared. A “Stability Fault” will cause a “Fault Detected” message to flash intermittently on the ITM display and drop the mA output to 0mA. The Modbus™ fault register bit for Stability Fault will be set and will not clear until the fault condition has been cleared. The sensor should be considered as ‘Out-of-Service’ until a successful AutoSpan calibration is performed.

Clearing Fault – AutoSpan

If the sensor fails the signal stability criteria (Section 3.4.2) during AutoSpan sequence, the “Clearing Fault” will be declared. A “Clearing Fault” will cause a “Fault Detected” message to flash intermittently on the ITM display and drop the mA output to 0mA. The Modbus™ fault register bit for Clearing Fault will be set and will not clear until the fault condition has been cleared. The sensor should be considered as ‘Out-of-Service’ until a successful AutoSpan calibration is performed.

Zero Fault

If the sensor drifts to < -10% of range, an “Under-Range Fault” will be declared. An “Under-Range Fault” will cause a “Fault Detected” message to flash intermittently on the ITM display. The Modbus™ fault register bit

for Under-Range Fault will be set and will not clear until the fault condition has been cleared. If an Under-Range Fault occurs, the 4-20mA signal will be set at 0mA until the fault condition is resolved.

Sensor Fault

If the intelligent plug-in sensor is not plugged in, plugged in incorrectly, or there is a communication failure, a “Sensor Fault” is declared. A “Sensor Fault” will cause a “Fault Detected” message to flash intermittently on the ITM display. The Modbus™ fault register bit for Sensor Fault will be set and will not clear until the fault condition has been cleared. If a Sensor Fault occurs, the 4-20mA signal will be set at 0mA until the fault condition is resolved.

Processor Fault

If the detector has any unrecoverable run-time errors, a “Processor Fault” is declared. A “Processor Fault” will cause a “Fault Detected” message to flash intermittently on the ITM display. The Modbus™ fault register bit for Processor Fault will be set and will not clear until the fault condition has been cleared. If a Processor Fault occurs, the 4-20mA signal will be set at 0mA until the fault condition is resolved.

Memory Fault

If the detector has a failure in saving new data to memory, a “Memory Fault” is declared. A “Memory Fault” will cause the “Fault Detected” message to flash intermittently on the ITM display. The Modbus™ fault register bit for Memory Fault will be set and will not clear until the fault condition has been cleared. If a Memory Fault occurs, the 4-20mA signal will be set at 0mA until the fault condition is resolved.

4-20mA Loop Fault

If the sensor detects a condition where the 4-20mA output loop is not functional (high loop resistance or failed circuit function) a “4-20mA Fault” is declared. A “4-20mA Fault” will cause the “Fault Detected” message to scroll once a minute on the ITM display. The Modbus™ fault register bit for Loop Fault will be set and will not clear until the fault condition has been cleared. If a Loop Fault occurs, the 4-20mA signal will be set at 0mA until the fault condition is resolved. If the 4-20mA current loop is still out of tolerance, contact Teledyne Detcon at detcon-sales@teledyne.com, or contact Teledyne Detcon customer service.

Input Voltage Fault

If the detector is currently receiving an input voltage that is outside of the 11.5-28VDC range, an “Input Voltage Fault” is declared. An “Input Voltage Fault” will cause the “Fault Detected” message to flash intermittently on the ITM display. The fault register bit for Input Voltage Fault will be set and will not clear until the fault condition has been cleared. If an Input Voltage Fault occurs, the 4-20mA signal will be set at 0mA until the fault condition is resolved.

Temperature Fault

If the detector is currently reporting an ambient temperature that is outside of the -20°C to $+55^{\circ}\text{C}$ range a “Temperature Fault” is declared. A “Temperature Fault” will cause the “Fault Detected” message to flash intermittently on the ITM display. The Modbus™ fault register bit for Temperature Fault will be set and will not clear until the fault condition has been cleared. If a Temperature Fault occurs, the 4-20mA signal remains operational.

AutoSpan Fault

If 180 days has elapsed since the last successful AutoSpan, an AutoSpan Fault will be generated. An “AutoSpan Fault” will cause the “Fault Detected” message to flash intermittently on the ITM display. The Modbus™ fault register bit for AutoSpan Fault will be set and will not clear until the fault condition has been cleared by executing a successful AutoSpan. If an AutoSpan occurs, the 4-20mA signal remains operational.

4. RS-485 Modbus™ Protocol

Model DM-700 sensors feature Modbus™ compatible communications protocol and are addressable via the program mode. Other protocols are available. Contact the Teledyne Detcon factory for specific protocol requirements. Communication is two wire, half duplex 485, 9600 baud, 8 data bits, 1 stop bit, no parity, with the sensor set up as a slave device. A master controller up to 4000 feet away can theoretically poll up to 256 different sensors. This number may not be realistic in harsh environments where noise and/or wiring conditions would make it impractical to place so many devices on the same pair of wires. If a multi-point system is being utilized, each sensor should be set for a different address. Typical address settings are: 01, 02, 03, 04, 05, 06, 07, 08, 09, 0A, 0B, 0C, 0D, 0E, 0F, 10, 11...etc.

Sensor RS-485 ID numbers are factory default to 01. These can be changed in the field via the Operator Interface described in Section 3.5.5 Set Serial ID.

The following section explains the details of the Modbus™ protocol that the DM-700 sensor supports.

Code 03 – Read Holding Registers is the only code supported by the transmitter. Each transmitter contains 6 holding registers which reflect its current status.

Table 3 Modbus™ Registers

FC	REG	Content Description	R/W	Content Definition		
				Value	Meaning	Range
03	40000	Device Type	R	8	700 Sensor	
03 06	40001 40001	Read Detectable Range ^{1,2} Write Detectable Range	R/W	100 10000	For 0-100 For 0-10000 ²	DM – 0 to 10000 FP – Read only TP – 20, 50, 100, 200 IR – 0 to 10000 PI – 0 to 10000
03	40002	Read Concentration ^{3,2}	R	1000	Bound by range. If > range, this value is in fault.	
03 06	40003 40003	Read AutoSpan Level ^{4,2} Write AutoSpan Level	R/W	50	Span gas at 50	DM – 1% to 95% of Range (40001) FP – 5% to 95% of Range (40001) TP – 2% to 50% of Range (40001) IR – 5% to 95% of Range (40001) PI – 1% to 95% of Range (40001)
03	40004	Read Sensor Life	R	85	For 85% sensor life	
03	40005	Read Fault Status Bits ⁵	R	0x0001 0x0002 0x0004 0x0008 0x0010 0x0020 0x0040 0x0080 0x0100 0x0200 0x0400 0x0800 0x1000 0x2000 0x4000 0x8000	Global Fault Auto Span Fault Temperature Fault 4-20mA Fault Input Voltage Fault Memory Fault Processor Fault Clearing Fault Stability Fault Range Fault Sensor Fault Zero Fault Sensor Fault 2 <reserved> In Calibration Communication Error	
03	40006	Read Model #	R	1, 2, 3, 4, 5	DM, FP, IR, TP, PID respectively	
03	40007	Read Days Since Cal	R	29	29days	
03	40008	4-20 Current Output mA x100	R	400	4.00mA	Range
03	40009	Read Input Voltage V x100	R	2400	24.00V	
03	40010	Read Temperature	R	28	28 °C	
03/ 06	40011	Special #1	R/W		Function dependent on value of 40006 (See Special Register Table 4)	
03/ 06	40012	Special #2	R/W		Function dependent on value of 40006 (See Special Register Table 4)	

FC	REG	Content Description	R/W	Content Definition		
				Value	Meaning	Range
03	40013	Special #3	R		Function dependent on value of 40006 (See Special Register Table 4)	
03/06	40014	Special #4	R/W		Function defendant on value of 40006 (See Special Register Table 4)	
03	40015	Calibration Status	R	0x0000 0x0001 0x0002 0x0003 0x0004	Idle Zero Calibration Started Span Calibration Started Span Set	
06	40015	Calibration Enable	W	0x0001 0x0002 0x0008 0x0009 0x000A 0x000B	Set Zero Set Span Signal simulation mode Set FP Bridge Voltage Set TP Heater Power Set IR Gain	
03	40016	Read Text 1, first char in L	R		Two Char of Gas/Units String ⁶	
03	40017	Read Text 2	R		Two Char of Gas/Units String ⁶	
03	40018	Read Text 3	R		Two Char of Gas/Units String ⁶	
03	40019	Read Text 4	R		Two Char of Gas/Units String ⁶	
03	40020	Read Text 5, last char in H	R		Two Char of Gas/Units String ⁶	
03	40021	Text null terminator in L	R		Two Char of Gas/Units String ⁶	

¹ Integer ranges from 1 all the way to 10,000.

² Units are determined by “units” field in the “notation” string

³ Gas Reading times one (*x 1*) with units in notation string for “Low Range” = 0. Gas Reading times one (*x 10*) with units in notation string for “Low Range” = 1. Gas Reading times one (*x 100*) with units in notation string for “Low Range” = 2.

⁴ Span Gas must be less than or equal to Detectable Range and is usually about ½ of it.

⁵ Fault status bits self-reset when fault clears

⁶ Text in ASCII, in order L byte, H byte, L byte... See field descriptions of notation string.

Gas/Units String

Character #	1	2	3	4	5	6	7	8	9	10	11
Description	Units			0x20	Gas Type						0x00

Units – This field is ‘PPM’, ‘PPB’, or ‘__ %’ (where ‘_’ is a space, 0x20).

0x20 – The units field is terminated with an ASCII space (0x20)

Gas Type – This field contains the gas type of the cell. Any ASCII string is permissible

0x00 – The notation string is terminated with an ASCII null character

Table 4 Modbus™ Special Registers

REG	DM (40006 = 1)	FP (40006 = 2)	IR (40006 = 3)	TP (40006 = 4) ¹	PI (40006 = 5)
40011	Low Range= 0, 1, 2 0: Range >25 (0 decimal place) 1: Range 10-25 (1 decimal place) 2: Range <10 (2 decimal place)	Gas Factor (R/W) Range = 79 to 565	Gas Factor (R/W) Range = 20 to 565	Heater Power (mW) (R/W)	Low Range= 0, 1, 2 0: Range >25 1: Range 10-25 2: Range <10
40012	0x8XXX Positive Polarity Cell 0x0XXX Negative Polarity Cell 0xX000 Bias = 0mV 0xX096 Bias = 150mV 0xX0C8 Bias = 200mV 0xX12C Bias = 300mV	Cal Factor (R/W) Range = 79 to 565	Active Counts	Heater Voltage (mV)	0x8XXX Positive Polarity Cell 0x0XXX Negative Polarity Cell 0xX096 Bias = 0mV 0xX0C8 Bias = 150mV 0xX12C Bias = 200mV 0xX12C Bias = 300mV
40013	Gain Code (integer between 0 & 15)	Bridge Current (mA)	Reference Counts	Sensor Resistance (x100 Ω)	Gain Code
40014	Raw Counts 0-0xFFFF (0x8000 = nominal 0)	Bridge Voltage (mV) (Read only)	Range Divisor 1,10,100, or 1000	Heater Current (mA)	Raw Counts

¹ Only possible ranges are 20, 50, 100, 200. Modbus register 40001 will contain either 20, 50, 100, or 200, range divisor is not necessary.

5. Service and Maintenance

Calibration Frequency

It is strongly recommended that a monthly re-calibration cycle be used with the PI-700 sensor. This is due to the UV lamp aging and is recommend to keep the unit in it's stated accuracy limits. Failure to maintain a monthly re-calibration frequency will result in diminished gas readings and is not recommended. If, after 180 days, an Auto-Span Calibration is not performed, the ITM will generate an AutoSpan Fault.

5.1 PID Plug-in Sensor Maintenance

The plug-in PID Sensor will need to be properly maintained to achieve proper long-term performance. All PID sensors use a UV lamp that has a finite lifetime. The Teledyne Detcon PID UV lamp source is expected to last at least 1 year. However, from the time of installation a gradual loss in UV lamp strength is expected (Figure 13). As the UV lamp strength decreases the sensor signal will decrease accordingly. This dictates that periodic span calibrations are required to maintain calibration accuracy. To determine the present signal strength of the PID sensor execute a valid span calibration and view the Sensor Life from the **'View Program Status'** menu. Any Sensor Life value less than 30% should result in the user's choice of replacing the plug-in sensor, cleaning the UV Lamp, or replacing the UV Lamp.

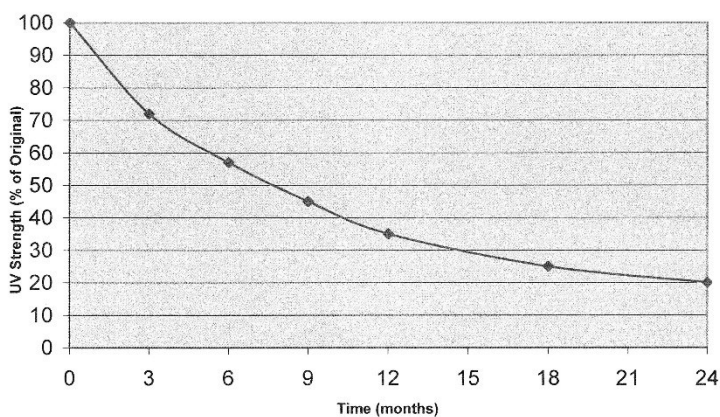

Figure 13 UV Lamp Aging Expectation

If the PID sensor appears to be losing signal strength at a rate faster than the estimates shown in Figure 13, the sensor is most likely experiencing contamination film build-up on the UV optical filter. This will happen when exposed to certain gases or ambient contaminations that collect on the surface of the UV filter. The result is a decrease in the amount of emitted UV light from the lamp source. This is known to happen with gases that can be polymerized by UV light (such as heavy complex VOC's), airborne oil vapors, and very fine dust. As UV Filter contamination occurs, the sensor's signal strength falls off in addition to the expected loss rate shown in Figure 13. This phenomenon can be reversed by disassembling the sensor and carefully cleaning the UV lamp filter using a specialized cloth.

A secondary filter accessory, built into the splashguard adapter, is used with the Model 700 PID sensors (Figure 14). This multi-stage filter is designed to prevent heavy and complex airborne VOC molecules from contacting the PID sensor and causing surface contamination and subsequent reading drift. When used effectively, it may extend the time between required sensor cleaning and / or sensor replacement. Its use is limited to application cases where the target gas(s) are moderate to small VOC molecules (i.e. benzene and smaller molecular weights). Before installing, it must be verified that the filter does not inhibit response to the target gas being monitored. Do not use this filter if the target gas response is inhibited. The service life of the filter may vary depending on the application; however, it is advised to change it out at least on a 18-24 month cycle.

In addition, a small moisture control packet (P/N 960-700PID-000) Figure 15 is banded around the plug-in PID sensor. This helps the sensor maintain better zero stability in extremely high humidity conditions. It is only to be used in conjunction with the secondary filter discussed previously. This moisture control packet should be replaced on an 18-24 month cycle.



Figure 14 Splashguard Adapter with Integral Filter

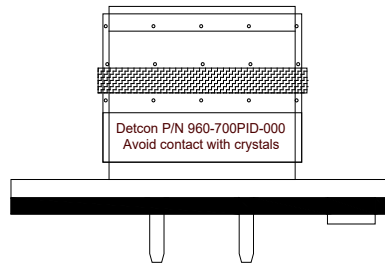

Figure 15 Plug-in sensor with Moisture control packet

It is also possible, under certain ambient contamination conditions, that the sensor's Detector Cell may have a partially conductive film that forms across the contact grids. This condition causes the zero background signal to gradually increase to the point where it becomes unacceptable for the range of signal input to the transmitter electronics. When this occurs the detector cell should be replaced. This can be checked by examining the amount of raw signal that is produced during exposure to zero gas. Refer to the '**View Program Status**' menu and record the Raw Signal report after 5 minutes of zero gas exposure. A value that exceeds 3000 counts would be evidence of this problem.

General recommendations for Sensor Maintenance

- ❖ For normal environmental exposure and signal decay, replace the plug-in sensor every 9-12 months. (especially if there are no skilled technicians to handle proper UV lamp replacement.)
- ❖ If skilled technicians are available, replace just the UV lamp every 9-12 months.
- ❖ For abnormally high rates of signal decay, clean the UV lamp monthly, using a Lamp Cleaning Kit, and replace the UV lamp every 9-12 months.
- ❖ For any proven cases where the zero baseline has drifted up, replace the detector cell.

All piD Sensor Cells contain six user replaceable components:

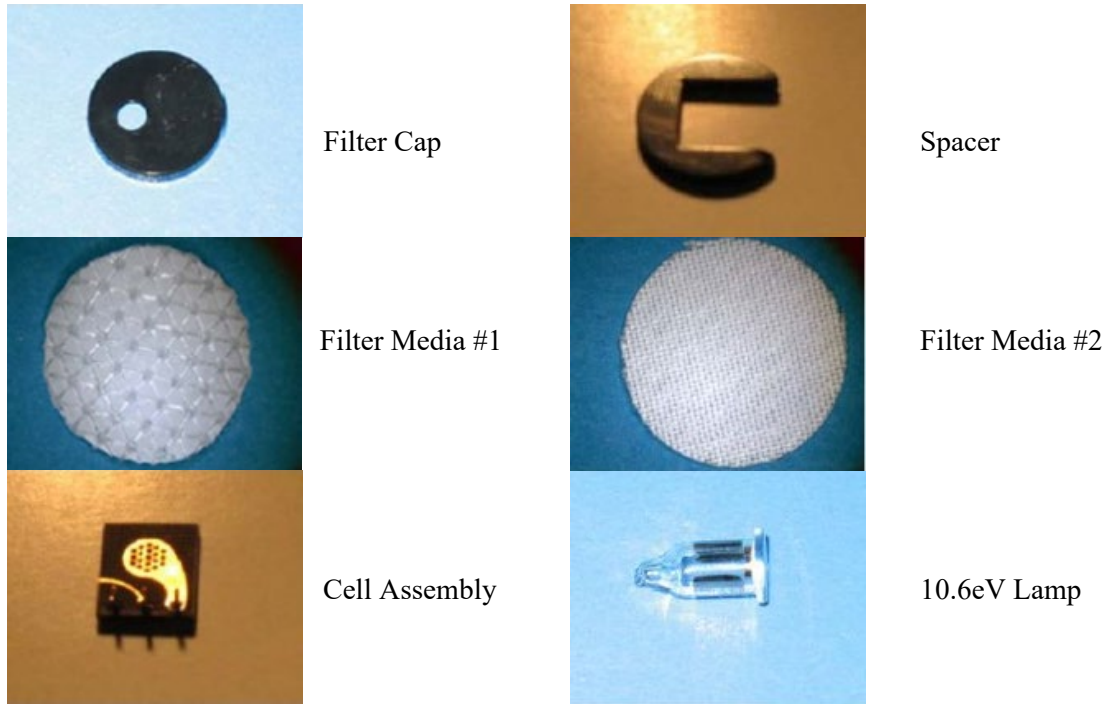

Figure 16 Sensor Cell Parts

NOTE: Avoid touching lamp’s window as well as any metal portion of the Detector Cell with bare fingers. It is acceptable to hold the lamp by its glass body or by the edges of the window. Fingerprints left on those parts may adversely affect the sensor’s operation. Use of cotton or latex gloves is suggested.

Disassembly

1. Power down the instrument and remove the sensor cell.
2. Remove the filter cap by applying a slight upward pressure with the tip of a screwdriver just below the hole in the cap and between the cap and the housing.



Figure 17 Removal of Filter Cap

3. With a fine-tipped tweezers, remove both the Filter Media and set aside.



Figure 18 Removal of Filter Media

4. Using the fine-tipped tweezers, remove the spacer and set it aside.



Figure 19 Removal of Spacer

5. With fine-tipped tweezers, carefully remove the cell assembly by prying under the cell's edge where the connector pins are located.



Figure 20 Removal of Cell Assembly

6. With soft-tipped tweezers, grasp the lamp by placing the tips in the housing notch and gently pulling it out. Be careful not to scratch the lamp lens or chip the edges.



Figure 21 Removal of Lamp

Cleaning the Lamp

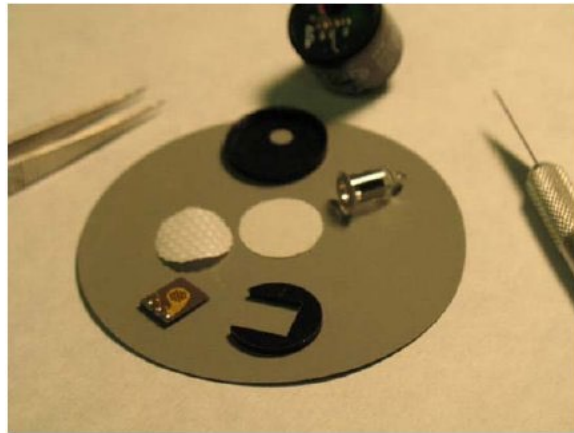

Figure 22 Lamp cleaning

Wearing gloves grab the lamp by the cylindrical glass body and clean the window by rubbing it against the Polishing Pad. Use a circular motion and try to keep the window surface flat relative to the pad. Five seconds of rubbing should be enough in most cases. Another indication of cleaning completeness is that about 1/16th of the pad surface is used during the process.



Figure 23 Polishing the Lamp

Reassembly

1. Install the lamp into the sensor, making sure that the lamp's metalized pads are aligned with the corresponding excitation springs inside the lamp cavity



Figure 24 Lamp installation

2. With the end of the clean tweezers, or a clean blade of a screwdriver, press down firmly, being careful not to scratch the surface of the lamp.



Figure 25 Lamp seating

3. Using fine tipped tweezers, install the cell assembly. Align the pins with the corresponding sockets on the sensor and push down on the end with the pins. Make sure the cell assembly is flush with the lamp window.



Figure 26 Cell Assembly installation

4. Place the spacer around the assembly.



Figure 27 Spacer installation

5. Place the filter media over the Cell Assembly centered on the top of the sensor. Make sure the filters are installed in the correct order. Filter Media #2 first, then Filter Media #1 on top, with the shiny side up.



Figure 28 Installing Filter Media

6. Align the Cap Key with the notch on the housing. Starting at the side opposite the notch, press down until the Filter Cap snaps on to the housing. If the Cap Key is incorrectly aligned there will be a noticeable bulge on the side of the cap.

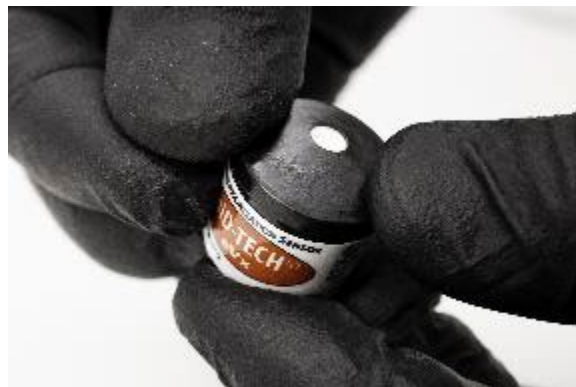

Figure 29 Replacing the Cap

Visual Inspection

The Sensor should be inspected annually. Inspect for signs of corrosion, pitting, and water damage. During visual inspection, the Splash Guard should be inspected to insure that it is not blocked. Examine the plug-in sensor for signs of physical blockage, electrolyte leakage, or severe corrosion. Also, inspect inside the Junction Box for signs of water accumulation or Terminal Block corrosion.

Condensation Prevention Packet

A moisture condensation packet should be installed in every explosion proof Junction Box. The moisture condensation prevention packet will prevent the internal volume of the J-Box from condensing and accumulating moisture due to day-night humidity changes. This packet provides a critical function and should be replaced annually. Teledyne Detcon's PN is 960-202200-000.

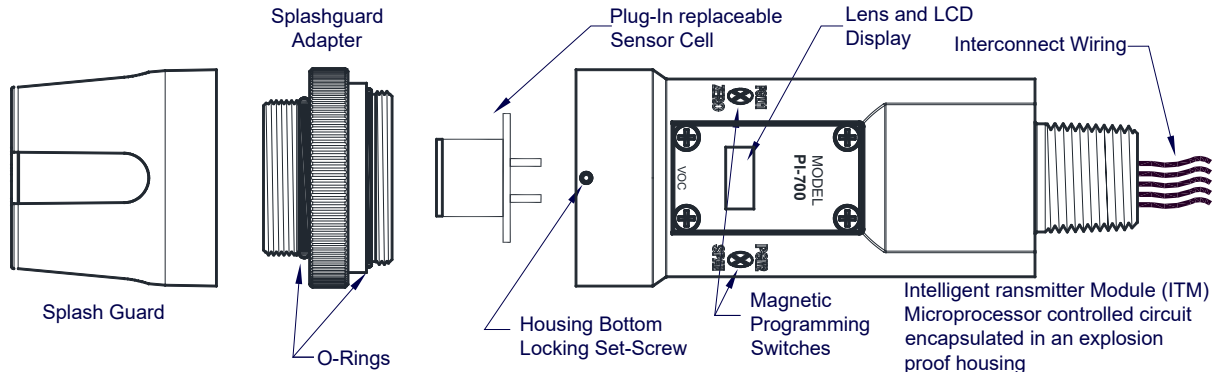

Figure 30 Sensor Assembly

5.2 Replacement of Intelligent Plug-in sensor

NOTE: It is not necessary to remove power while changing the Intelligent plug-in VOC gas sensor in order to maintain area classification, since it is intrinsically safe.

- Use a 1/16" Allen wrench to release the locking setscrew that locks the ITM and Splash Guard Adapter together (One turn will suffice – Do not remove setscrew completely).
- Remove splashguard. Unthread and remove the Splash Guard Adapter from the ITM.
- Gently pull the plug-in sensor out of the ITM. Remove moisture control packet if supplied. Transfer to new plug-in sensor. Orient the new plug-in sensor so that it matches with the female connector pins. When properly aligned, press the sensor in firmly to make the proper connection.

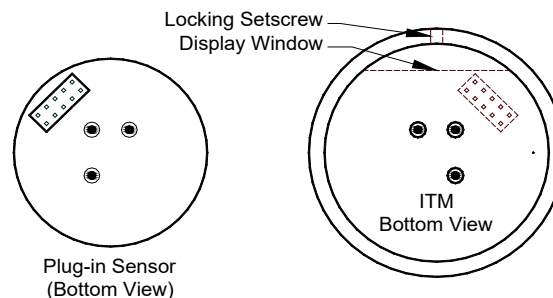

Figure 31 Sensor Cell and ITM Mating

- Thread the Splash Guard Adapter onto the ITM to a snug fit and tighten the locking setscrew using the 1/16" Allen wrench. Reinstall the splashguard.
- Verify the gas type and range of the new sensor by checking in View Program Status. It is recommended "AutoZero and AutoSpan functions be performed, as per Section 3.4, to match the new intelligent plug-in sensor with the ITM.

5.3 Replacement of ITM



CAUTION: Hazardous areas must be declassified before opening the junction box or removing and replacing the ITM.

- a) Remove the power source from the sensor assembly. Disconnect all sensor wire connections at the J-Box taking note of the wire connections.
- b) Use a wrench and loosen the locking nut at the top of the ITM and unthread the ITM from the junction box..
- c) Use a 1/16” Allen wrench to release the locking setscrew that locks the ITM and Splash Guard Adapter together (One turn will suffice – Do not remove setscrew completely).
- d) Remove splashguard. Unthread and remove the Splash Guard Adapter from the ITM.
- e) Gently remove the plug-in gas sensor from the old ITM and install it in the new ITM. Orient the plug-in sensor pins so that they match with the female connector sockets on the new ITM then press the sensor in firmly to make proper connection.
- f) Thread the Splash Guard Adapter onto the ITM until snug, tighten the locking setscrew and reconnect splashguard.
- g) Feed the sensor assembly wires through the 3/4” female NPT mounting hole and thread the assembly into the J-box until tight and the ITM lens faces toward the front access point. Connect the sensor assembly wires inside J-Box (Refer to Section 2.6, and Figure 10).
- h) Perform Set AutoSpan Level, Set Serial ID, Set Range, and then perform a successful AutoZero and AutoSpan before placing sensor into service.

5.4 Replacement of PI-700 Sensor Assembly



CAUTION: Hazardous areas must be declassified before removing the junction box cover or replacing the sensor assembly.

- a) Remove the power source from the sensor assembly. Disconnect all sensor wire connections at the J-Box.
- b) Use a wrench and loosen the locking nut at the top of the ITM and unthread the ITM from the junction box.
- c) Use a 1/16” Allen wrench to release the locking setscrew that locks the ITM and Splash Guard Adapter together (One turn will suffice – Do not remove setscrew completely).
- d) Remove splashguard. Unthread and remove the Splash Guard Adapter from the ITM.
- e) Feed the new PI-700 sensor assembly wires through the 3/4” female NPT mounting hole and thread the assembly into the J-box until tight and the ITM lens faces toward the front access point. Connect the sensor assembly wires inside J-Box (Refer to Section 2.6, and Figure 10).
- f) PI-700 sensors are factory calibrated, however, they require an initial AutoZero and AutoSpan calibration (Section 3.4), and must be configured per customer specific application requirements.

6. Troubleshooting Guide

Refer to the list of Failsafe Diagnostic features listed in Section 3.6.2 for additional reference in troubleshooting activities. Listed below are some typical trouble conditions and their probable cause and resolution path.

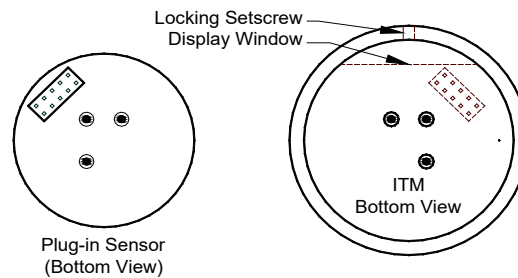

Figure 32 Sensor Cell and ITM Mating

Under-Range Fault

Probable Cause: Sensor Baseline drifted lower, Ambient Interference gasses reduced.

- Repeat AutoZero. Use Zero Air or N₂ source.
- Execute successful AutoSpan and verify adequate Sensor Life.
- Check Raw counts in View Sensor Status. Count should be close to 1,500 for high range and 3,000 for low range.
- Replace plug-in sensor if fault continues.

Missing Sensor Fault

Probable Cause: Sensor is Missing, Failed Plug-in Sensor Electronics, or ITM I.S. Barrier Failure.

- Make sure plug-in sensor is plugged in properly with correct orientation.
- Swap plug-in sensor into another ITM to determine if plug-in sensor problem or ITM problem.
- Replace the plug-in sensor if proven faulty.
- Replace the ITM if proven faulty.

AutoSpan Calibration Faults – (Range, Stability and Clearing)

To clear any AutoSpan Calibration fault, the AutoSpan process must be completed successfully (Section 3.4).

Use zero air gas after AutoSpan Calibration to avoid clearing fault from high background VOC levels.

Range Fault

Probable Causes: Failed Sensor, Cal Gas not applied or not applied at appropriate time, or problems w/ cal gas and delivery.

- Check validity of span gas (check MFG date on cal gas cylinder).
- Use proper cal gas regulators and tubing for highly absorbing or corrosive gasses.
- If using Splashguard with Integral Cal Port, must use Calibration Wind Guard or air movement can compromise span gas delivery.
- Check for obstructions affecting cal gas hitting sensor face (including being wet, blocked, or corroded).
- Verify adequate Sensor Life.
- Clean or replace the PID lamp.
- Replace the plug-in VOC sensor.

Stability Fault

Probable Causes: Failed Sensor, empty or close to empty Cal Gas Cylinder, or problems with cal gas and delivery.

- Check validity of span gas using pull tube or other means (check MFG date on cal gas cylinder).
- Use proper cal gas regulators and tubing for highly corrosive gasses.
- If using Splashguard with Integral Cal Port, must use Calibration Wind Guard or air movement can compromise span gas delivery.
- Check for obstructions affecting cal gas hitting sensor face (including being wet, blocked, or corroded).
- Verify adequate Sensor Life.
- Clean or replace the PID lamp.
- Replace the plug-in VOC sensor.

Clearing Fault

Probable Causes: Failed Sensor, Cal Gas not removed at appropriate time, problems with cal gas and delivery, or background of Target Gas.

- Must recover to < 5% of range in < 5 min after AutoSpan is complete.
- Use bottled air (zero air or N₂) if there is a known continuous background level.
- Check validity of span gas using pull tube or other means (check MFG date on cal gas cylinder).
- Use proper cal gas regulators and tubing for highly corrosive gasses.
- Check for obstructions affecting cal gas hitting sensor face (including being wet, blocked, or corroded).
- Verify adequate Sensor Life.
- Clean or replace the PID lamp.
- Replace the plug-in VOC sensor.

Poor Calibration Repeatability

Probable Causes: Failed Sensor, use of wrong Cal Gas or problems with cal gas and delivery, or Interference Gasses.

- Check for adequate Sensor Life.
- Check validity of span gas using pull tube or other means (check MFG date on cal gas cylinder).
- Use proper cal gas regulators and tubing for highly corrosive gasses.
- Check for obstructions affecting cal gas hitting sensor face (including being wet, blocked, or corroded).
- Verify adequate Sensor Life.
- Clean or replace the PID lamp.
- Replace the plug-in VOC sensor.

Unstable Output/ Sudden spiking

Possible Causes: Unstable power supply, inadequate grounding, or inadequate RFI protection.

- Verify Power source is stable.
- Verify field wiring is properly shielded and grounded.
- Contact Teledyne Detcon to optimize shielding and grounding.

Nuisance Alarms

- Check condulet for accumulated water and abnormal corrosion on terminal blocks.
- If nuisance alarms are happening at night suspect condensation in condulet.
- Add or replace Teledyne Detcon's Condensation Prevention Packet P/N 960-202200-000.
- Investigate the presence of other target gasses that are causing cross-interference signals.
- Determine if cause is RFI induced.

Processor and/or Memory Faults

- Recycle power in attempt to clear problem
- Restore Factory Defaults – This will clear the processor's memory and may correct problem.

- Remember to re-enter all customer settings for range and cal gas level after Restore Factory Defaults.
- If problem persists, replace the Intelligent Transmitter Module.

Unreadable Display

If due to excessive sunlight, install a sunshade to reduce glare.

Nothing Displayed – Transmitter not Responding

- Verify conduit has no accumulated water or abnormal corrosion.
- Verify required DC power is applied to correct terminals.
- Swap with a known-good ITM to determine if ITM is faulty.

Faulty 4-20 mA Output

If Sensor has a normal reading with no Faults displayed, and the 4-20 mA signal output is 0mA....

- Check that wiring is properly connected at terminal blocks and through to controller inputs.
- The 4-20 output loop must be closed (resistance of < 1000 ohms) to avoid the Loop Fault.
- Perform a “Signal Output Check” sequence via Section 3.5.7 and verify 4-20mA output with Current Meter.
- Swap with new ITM to determine if the ITM’s 4-20mA output circuit has failed.
- If the 4-20mA current loop is still out of tolerance, contact Teledyne Detcon at detcon-service@teledyne.com, or contact Teledyne Detcon customer service.

No Communication – RS-485 Modbus™

If sensor has a normal reading with no Faults displayed and the Modbus™ is not communicating....

- Verify that the correct (and non-duplicated) serial address is entered (per Section 3.5.3).
- Check that the wiring is properly connected at terminal blocks, and the serial loop is wired correctly.
- Perform a “Signal Output Check” per Section 3.5.7 and troubleshoot wiring.
- Consider adding a Modbus™ repeater if the distance from the nearest distribution drop is excessive.
- Swap with new ITM to determine if the ITM’s serial output circuit is faulty.
- Refer to Teledyne Detcon’s “Guide to Proper Modbus™ Communications” Application Note.

7. Customer Support and Service Policy

Teledyne Detcon

Shipping Address: 14880 Skinner Road, Cypress, Texas 77429

Phone: 713.559.9200

- www.teledynegasandflamedetection.com
- detcon-service@teledyne.com
- detcon-sales@teledyne.com

All Technical Service and Repair activities should be handled by the Teledyne Detcon Service Department via phone or email at contact information given above. RMA numbers should be obtained from the Teledyne Detcon Service Department prior to equipment being returned. For on-line technical service, customers should have ready the model number, part number, and serial number of product(s) in question.

All Sales activities (including spare parts purchase) should be handled by the Teledyne Detcon Sales Department via phone or email at contact information given above.

Warranty Notice

Teledyne Detcon Inc. warrants the Model PI-700 VOC gas sensors to be free from defects in workmanship and material under normal use and service for two years from the date of shipment on the ITM electronics, and for the conditional warranty period of twelve months on the intelligent plug-in sensor.

Teledyne Detcon Inc. will repair or replace without charge any such equipment found to be defective during the warranty period. Full determination of the nature of, and responsibility for, defective or damaged equipment will be made by Teledyne Detcon Inc. personnel.

Defective or damaged equipment must be shipped to the Teledyne Detcon Inc. factory or representative from which the original shipment was made. In all cases, this warranty is limited to the cost of the equipment supplied by Teledyne Detcon Inc. The customer will assume all liability for the misuse of this equipment by its employees or other contracted personnel.

All warranties are contingent upon the proper use in the application for which the product was intended and does not cover products which have been modified or repaired without Teledyne Detcon Inc. approval, or which have been subjected to neglect, accident, improper installation or application, or on which the original identification marks have been removed or altered.

Except for the express warranty stated above, Teledyne Detcon Inc. disclaims all warranties with regard to the products sold. Including all implied warranties of merchantability and fitness and the express warranties stated herein are in lieu of all obligations or liabilities on the part of Teledyne Detcon Inc. for damages including, but not limited to, consequential damages arising out of, or in connection with, the performance of the product.

8. PI-700 Sensor Warranty

Intelligent Plug-in Sensor Warranty

Teledyne Detcon Inc. warrants, under normal intended use, each new intelligent plug-in sensor for a period of twelve months and under the conditions described as follows: The warranty period begins on the date of shipment to the original purchaser. The sensor element is warranted to be free of defects in material and workmanship. Should any sensor fail to perform in accordance with published specifications within the warranty period, return the defective part to Teledyne Detcon, Inc., 14880 Skinner Road, Cypress, Texas 77429, for necessary repairs or replacement.

NOTE: The warranty only covers parts not working. This warranty does not cover conditions where the detector cell or lamp may be dirty and can be restored by cleaning.

Terms & Conditions

- * The original serial number must be legible on each sensor element base.
- * Shipping point is FOB the Teledyne Detcon factory.
- * Net payment is due within 30 days of invoice.
- * Teledyne Detcon, Inc. reserves the right to refund the original purchase price in lieu of sensor replacement.

ITM Electronics Warranty

Teledyne Detcon Inc. warrants, under intended normal use, each new Model 700 ITM to be free from defects in material and workmanship for a period of two years from the date of shipment to the original purchaser. All warranties and service policies are FOB the Teledyne Detcon facility located in Cypress, Texas.

Terms & Conditions

- * The original serial number must be legible on each ITM.
- * Shipping point is FOB the Teledyne Detcon factory.
- * Net payment is due within 30 days of invoice.
- * Teledyne Detcon, Inc. reserves the right to refund the original purchase price in lieu of ITM replacement.

9. Appendix

9.1 Specifications

System Specifications

Sensor Type:	Continuous diffusion/adsorption type Photo Ionization Detector – PID Plug-in Replaceable Intelligent Type (with replaceable Lamp)
Sensor Life:	2 years typical
Measuring Ranges:	Gas Dependent, ranges as low as 0-10ppm or as high as 0-5,000ppm
Accuracy/ Repeatability:	±20% of reading
Response Time:	T50 <30 seconds; T90 < 60 seconds
Outputs:	Linear 4-20mA DC RS-485 Modbus™ RTU
Electrical Classification:	Explosion Proof CSA and US (NRTL) Class I, Division 1, Groups A,B,C,D T4 (Tamb=-20° to +55°C) Class I, Zone 1, Group IIC, T4 ATEX & IECEX II 2G Ex db ia IIC T4 Gb (Tamb=-20°C to +55°C) IEC 60079-0:2017 IEC 60079-1:2014 IEC 60079-11:2011
Safety Approvals:	cCSAus (CSA06CA1808890X) ATEX (KEMA 06ATEX2153X) IECEX (DEK 22.0063X) IECEX (DEK 22.0064U) Enclosure type 897-850901-010 and 897-850000-010 IECEX (DEK 22.0065U) Enclosure type 897-850901-316 and 895-850000-316 CE (2575)
Ingress Protection:	NEMA 4X, IP66
Safety and Reliability:	CE Marking cCSAus, ATEX, IECEX
Warranty:	Plug-in detector – 1 year Transmitter – 2 years

Environmental Specifications

Operating Temperature:	-4°F to +122°F; -20°C to +55°C
Storage Temperature:	-4°F to +122°F; -20°C to +55°C
Operating Humidity:	0-100% RH Non-Condensing

Mechanical Specifications

Dimensions

Sensor Assembly Only

7.8”H x 2.125” Dia.; 198mmH x 54mm Dia.

Stainless Steel Junction Box

12.5”H x 6.1”W x 4”D; 317mmH x 155mmW x 101mmD
Mounting holes (J-box) 5.5”; 140mm center to center

Aluminum Junction Box

13”H x 6.1”W x 4”D; 330mmH x 155mmW x 101mmD
Mounting holes (J-box) 5.5”; 140mm center to center

Weight:

2 lbs; 0.907kg (sensor only)
6 lbs; 2.72kg (w/aluminum j-box)
9 lbs; 4.08kg (w/stainless steel j-box)

Electrical Specifications

Input Voltage:

11-30 VDC

Power Consumption:

Normal operation = 68mA (<1.7 watt)
Maximum = 85mA (2 watts)

Inrush current:

1.67A @ 24V

RFI/EMI Protection:

Complies with EN50270:2015

Analog Output:

Linear 4-20mA DC current (1000 ohms maximum loop load @ 24VDC)
0mA All Fault Diagnostics
2mA In-Calibration
4-20mA 0-100% full-scale
22mA Over-range condition

Serial Output:

RS-485 Modbus™ RTU

Baud Rate:

9600 BPS (9600,N,8,1 Half Duplex)

Status Indicators:

4-digit LED Display with gas concentration
full-script menu prompts for AutoSpan,
Set-up Options, and Fault Reporting

Faults Monitored:

Loop, Input Voltage,
Zero, Missing Sensor,
Processor, Memory, Calibration

Cable Requirements:

Power/Analog: 3-wire shielded cable
Maximum distance is 13,300 feet with 14 AWG

Serial Output: 2-wire twisted-pair shielded cable specified for RS-485 use
Maximum distance is 4,000 feet to last sensor

I/O Protection:

Over-Voltage, Miss-wiring, EMI/RFI Immunity

9.2 Gas Reference Table

Table 5 Gas Factor Table

Compound Name	Synonym/Abbreviation	Formula	Response Factor	¹ Confirmed Value	IP (eV)	TWA
Acetaldehyde		C2H4O	5.5	+	10.23	C25
Acetic Acid	Ethanoic Acid	C2H4O2	22	+	10.66	10
Acetic Anhydride	Ethanoic Acid Anhydride	C4H6O3	6.1	+	10.14	5
Acetone	2-Propanone	C3H6O	1.1	+	9.71	500
Acetonitrile	Methyl cyanide, Cyanomethane	C2H3N	NR		12.19	40
Acetylene	Ethyne	C2H2	NR		11.40	ne
Acrolein	Propenal	C3H4O	3.9	+	10.10	0.1
Acrylic Acid	Propenoic Acid	C3H4O2	12	+	10.60	2
Acrylonitrile	Propenenitrile	C3H3N	NR	+	10.91	2
Allyl alcohol		C3H6O	2.4	+	9.67	2
Allyl chloride	3-Chloropropene	C3H5Cl	4.3		9.9	1
Ammonia		H3N	9.7	+	10.16	25
Amyl alcohol	mix of n-pentyl acetate & 2-Methylbutyl acetate	C5H12O	5		10.00	100
Aniline	Aminobenzene	C7H7N	0.5	+	7.72	2
Anisole	Methoxybenzene	C7H8O	0.8		8.21	ne
Arsine	Arsenic trihydride	AsH3	1.9	+	9.89	0.05
Benzaldehyde		C7H6O	?		9.49	ne
Benzene		C6H6	0.5	+	9.25	0.5
Benzonitrile	Cyanobenzene	C7H5N	1.6		9.62	ne
Benzyl alcohol	a-Hydroxytoluene, Hydroxymethylbenzene, Benzenemethanol	C7H8O	1.1	+	8.26	ne
Benzyl chloride	a-Chlorotoluene, Chloromethylbenzene	C7H7Cl	0.6	+	9.14	1
Benzyl formate	Formic acid benzyl ester	C8H8O2	0.73	+		ne
Boron trifluoride		BF3	NR		15.5	C1
Bromine		Br3	1.30	+	10.51	0.1
Bromobenzene		C6H5Br	0.6		8.98	ne
2-Bromoethyl methyl ether		C3H7OBr	0.84	+	~10	ne
Bromoform	Tribromomethane	CHBr3	2.5	+	10.48	0.5
Bromopropane, 1-	n-Propyl bromide	C3H7Br	1.5	+	10.18	ne
Butadiene	1,2-Butadiene, Vinyl ethylene	C4H6	0.85	+	9.07	2
Butadiene diepoxide, 1, 3-	1,2,3,4-Diepoxybutane	C4H6O2	3.5	+	~10	ne
Butane		C4H10	67		10.53	ne
Butanol, 1-	Butyl alcohol, n-Butanol	C4H10O	4.7	+	9.99	C50
Butanol, t-	tert-butanol, t-Buty alcohol	C4H10O	2.9	+	9.90	100
Butene, 1-	1-Butylene	C4H8	0.9		9.58	ne
Butoxyethanol, 2-	Butyl Cellosolve, Ethyleneglycol monobutyl ether	C6H14O2	1.2	+	<10	25
Butyl acetate, n-		C6H12O2	2.6	+	10	150
Butyl acrylate, n-	Butyl 2-propenoate, Acrylic acid butyl ester	C7H12O2	1.6	+		10
Butylamine, n-		C4H11N	1.1	+	8.71	C5
Butyl cellosolve	see 2-Butoxyethanol					

¹ NR = not recommended (does not register)

? = measurable but no data exist

Confirmed Value = “+” means actual gas has been used to verify RF, “blank” means it is an empirical estimate

IP = is the gases ionization potential (only gases < 10.6eV will respond to sensor)

TWA/Time Weighted Average = generally accepted limit for safe 8 hour exposure (in ppm)

ne = None Established

<i>Compound Name</i>	<i>Synonym/Abbreviation</i>	<i>Formula</i>	<i>Response Factor</i>	<i>¹Confirmed Value</i>	<i>IP (eV)</i>	<i>TWA</i>
Butyl hydroperoxide, t-		C4H10O2	1.6	+	<10	1
Butyl mercaptan	1-Butanethiol	C4H10S	0.52	+	9.14	0.5
Carbon disulfide		CS2	1.2	+	10.07	10
Carbon monoxide		CO	NR	+	14.07	50
Carbon tetrachloride	Tetrachloromethane	CCl4	NR	+	11.47	5
Carbonyl sulfide	Carbon Oxy sulfide	COS	NR		11.18	
Cellosolve (see 2-Ethoxyethanol)						
CFC-14 (see Tetrafluoromethane)						
CFC-113 (see 1,1,2-Trichloro-1,2,2-trifluoroethane)						
Chlorine		Cl2	NR		11.48	0.5
Chlorine dioxide		ClO2	NR	+	10.57	0.1
Chloro-1,3-butadiene, 2-	Chloroprene	C4H5Cl	3			10
Chlorobenzene	Monochlorobenzene	C6H5Cl	0.40	+	9.06	10
Chloro-1, 1-difluoroethane, 1-(R-142B)		C2H3ClF2	NR		12.0	
Chlorodifluoromethane	HCFC-22, R-22	CHClF2	NR		12.2	1000
Chloroethane	Ethyl chloride	C2H5Cl	NR	+	10.97	100
Chloroethanol	Ethylene chlorhydrin	C2H5ClO			10.52	C1
Chloroethyl ether, 2-	bis(2-chloroethyle) ether	C4H8Cl2O	3.0	+		5
Chloroethyl methyl ether,2-	Methyl 2-chloroethyl ether	C3H7ClO	3			ne
Chloroform	Trichloromethane	CHCl3	NR	+	11.37	10
Chloropicrin		CCl3NO2	~400	+	?	0.1
Chlorotoluene, o-	o-Chloromethylbenzene	C7H7Cl	0.5		8.83	50
Chlorotoluene, p-	p-Chloromethylbenzene	C7H7Cl	0.5		8.69	ne
Crotonaldehyde	trans-2-Butenal	C4H6O	1.1	+	9.73	2
Cumene	Isopropylbenzene	C9H12	0.54	+	8.73	50
Cyanogen bromide		CNBr	NR		11.84	ne
Cyanogen chloride		CNCl	NR		12.34	C0.3
Cyclohexane		C6H12	1.4	+	9.86	300
Cyclohexanol	Cyclohexyl alcohol	C6H12O	?		9.75	50
Cyclohexanone		C6H10O	0.9	+	9.14	25
Cyclohexene		C6H10	0.8	+	8.95	300
Cyclohexylamine		C6H13N	1.2		8.62	10
Cyclopentane		C5H10	?		10.51	600
Decane		C10H22	1.4	+	9.65	ne
Diacetone alcohol	4-Methyl-4-hydroxy-2- pentanone	C6H12O2	0.7			50
Dibromoethane,1,2-	EDB, Ethylene dibromide, Ethylene bromide	C2H4Br2	1.7	+	10.37	ne
Dichlorobenzene, o	1,2-Dichlorobenzene	C6H4Cl2	0.47	+	9.08	
Dichlorodifluoromethane	CFC-12	CCl2F2	NR	+	11.75	1000
Dichloroethane, 1,2-	EDC, 1,2-DCA, Ethylene dichloride	C2H4Cl2	NR	+	11.04	10
Dichloroethene, 1,1-	1,1-DCE, Vinylidene chloride	C2H2Cl2	0.9		9.79	5
Dichloroethene, c-1,2-	c-1,2-DCE, cis-Dichloroethylene	C2H2Cl2	0.8		9.66	200
Dichloroethene, t-1,2-	t-1,2-DCE, trans- Dichloroethylene	C2H2Cl2	0.45	+	9.65	200
Dichloro-1-fluoroethane, 1,1-	R-141B	C2H3Cl2F	NR	+		ne
Dichloromethane (see Methylene chloride)						

Compound Name	Synonym/Abbreviation	Formula	Response Factor	¹ Confirmed Value	IP (eV)	TWA
Dichloropentafluoropropane	AK-255, mix of ~45% 3,3-dichloro-1,1,1,2,2-pentafluoropropane (HCFC-225ca) & ~55% 1,3-Dichloro-1,1,2,2,3-pentafluoropropane (HCFC-225cb)	C3HC12F5	NR	+		ne
Dichloropropane, 1,2		C3H6Cl2	NR		10.87	75
Dichloro-1-propene, 1,3-		C3H4Cl2	0.96	+	<10	1
Dichloro-1-propene, 2,3-		C3H4Cl2	1.3	+	<10	ne
Dichloro-1,1,1-trifluoroethane, 2,2-	R123	C2HC12F3	NR	+	11.5	ne
Dichlorvos	Vapona; O,O-dimethyl O-dichlorovinyl phosphite	C4H7Cl2O4P	0.9	+	<9.4	0.1
Dicyclopentadiene	DCPD, Cyclopentadiene dimer	C10H12	0.5	+	8.8	5
Diesel Fuel #1		m.w. 226	0.9	+		
Diesel Fuel #2		m.w. 216	0.7	+		
Diethylamine		C4H11N	1	+	8.01	5
Diethylaminopropylamine, 3-		C7H18N2	1.3			
Diethylmaleate		C8H12O4	4			ne
Diethyl sulfide	see Ethyl sulfide					
Diisopropylamine		C6H15N	0.74	+	7.73	5
Diketene	Ketene dimer	C4H4O2	2.0	+	9.6	0.5
Dimethylacetamide, N,N-	DMA	C4H9NO	0.8	+	8.81	10
Dimethylamine		C2H7N	1.5		8.23	5
Dimethyl carbonate	Carbonic acid dimethyl ester	C3H6O3	~70	+	~10.5	ne
Dimethyl disulfide	DMDS	C2H6S2	0.20	+	7.4	ne
Dimethylethylamine	DMEA	C4H11N	1.0	+	7.74	~3
Dimethylformamide, N,N-	DMF	C3H7NO	0.8		9.13	10
Dimethylhydrazine, 1,1-	UDMH	C2H8N2	0.8	+	7.28	0.01
Dimethyl methylphosphonate	DMMP, methyl phosphonic acid dimethyl ester	C3H9O3P	4.3	+	10.0	ne
Dimethyl sulfate		C2H6O4S	~20	+		0.1
Dimethyl sulfide	see Methyl sulfide					
Dimethyl sulfoxide	DMSO, Methyl sulfoxide	C2H6OS	1.4	+	9.10	ne
Dioxane, 1,4-		C4H8O2	1.3		9.19	25
Dowtherm A see Therminol						
DS-108F Wipe Solvent	Ethyl lactate/Isopar H/ Propoxypropanol ~7:2:1	m.w. 118	1.6	+		ne
Epichlorohydrin	ECH Chloromethyloxirane, 1-chloro-2,3-epoxypropane	C2H5ClO	8.5	+	10.2	0.5
Ethane		C2H6	NR	+	11.52	ne
Ethanol	Ethyl alcohol	C2H6O	12	+	10.47	1000
Ethanolamine (not recommended)	MEA, Monoethanolamine	C2H7NO	1.6	+	8.96	3
Ethene	Ethylene	C2H4	10	+	10.51	ne
Ethoxyethanol, 2-	Ethyl cellosolve, Ethylene glycol monoethyl ether	C4H10O2	1.3		9.6	5
Ethyl acetate		C4H8O2	4.6	+	10.01	400
Ethyl acrylate		C5H8O2	2.4	+	(<10.3)	5
Ethylamine		C2H7N	0.8		8.86	5
Ethylbenzene		C8H10	0.52	+	8.77	100
Ethylene glycol	1,2-Ethanediol	C2H6O2	16	+	10.16	C100
Ethylene oxide	Oxirane, Epoxyethane	C2H4O	13	+	10.57	1
Ethyl ether	Diethyl ether	C4H10O	1.1	+	9.51	400
Ethyl 3-ethoxypropionate	EEP	C7H14O3	0.75	+		ne
Ethyl formate		C3H6O2	?		10.61	100
Ethyl hexyl acrylate, 2-	Acrylic acid 2-ethylhexyl ester	C11H20O2	1.1	+		ne

<i>Compound Name</i>	<i>Synonym/Abbreviation</i>	<i>Formula</i>	<i>Response Factor</i>	<i>¹Confirmed Value</i>	<i>IP (eV)</i>	<i>TWA</i>
Ethyl (S)-(-)-lactate see also DS-108F	Ethyl lactate, Ethyl (S)-(-)-hydroxypropionate	C5H10O3	3.2	+	~10	ne
Ethyl mercaptan	Ethanethiol	C2H6S	0.56	+	9.29	0.5
Ethyl sulfide	Diethyl sulfide	C4H10S	0.5	+	8.43	ne
Formaldehyde	Formalin	CH2O	?		10.87	C0.3
Formic acid		CH2O2	NR	+	11.33	5
Furfural	2-Furaldehyde	C5H4O2	0.92	+	9.21	2
Furfuryl alcohol		C5H6O2	0.80	+	<9.5	10
Gasoline #1		m.w. 72	0.9	+		300
Gasoline #2, 92 octane		m.w. 93	1.0	+		300
Glutaraldehyde	1,5-Pentanedial, Glutaric dialdehyde	C5H8O2	0.8	+		C0.0
Halothane	2-Bromo-2-chloro-1,1,1-trifluoroethane	C2HBrClF3	NR			
HCFC-22 (see Chlorodifluoromethane)						
HCFC-123 (see 2,2-Dichloro-1,1,1-trifluoroethane, R-123)						
HCFC-141B (see 1,1-Dichloro-1-fluoroethane)						
HCFC-142B (see 1-Chloro-1,1-difluoroethane)						
HCFC-134A (see 1,1,1,2-Tetrafluoroethane)						
HCFC-225 (see Dichloropentafluoropropane)						
Heptane, n-		C7H16	2.8	+	9.92	400
Hexamethyldisilazane, 1,1,1,3,3,3-	HMDS	C6H19Nsi2	0.2	+	~8.6	
Hexane, n		C6H14	4.3	+	10.13	50
Hexanol, 1-	Hexyl alcohol	C6H14O	2.5	+	9.86	ne
Hexene, 1-		C6H12	0.8		9.44	30
Hydrazine		H4N2	2.6	+	8.1	
Hydrogen	Synthesis gas	H2	NR	+	15.43	ne
Hydrogen cyanide	Hydrocyanic acid	HCN	NR	+	13.60	C4.7
Hydrogen peroxide		H2O2	NR	+	10.54	1
Hydrogen sulfide		H2S	3.3	+	10.45	10
Iodine		I2	0.1	+	9.40	C0.1
Iodomethane	Methyl iodide	CH3I	0.2	+	9.54	2
Isoamyl acetate	Isopentyl acetate	C7H14O2	2.1		<10	100
Isobutne	2-Methylpropane	C4H10	100	+	10.57	ne
Isobutanol	2-Methyl-2-propanol	C4H10O	3.8	+	10.02	50
Isobutylene	Isobutxene, Methyl butene	C4H8	1.00	+	9.24	ne
Isobutyl acetate		C6H12O2	2.6			150
Isobutyl acrylate	Isobutyl 2-propenoate, Acrylic acid Isobutyl ester	C7H12O2	1.5	+		ne
Isoflurane	1-Chloro-2,2,2-trifluoroethyl difluoromethyl ether, forane	C3H2ClF5O	NR		~11.7	ne
Isooctane	2,2,4-Trimethylpentane	C8H18	1.2		9.86	ne
Isopar E Solvent	Isoparaffinic hydrocarbons	m.w. 121	0.8	+		ne
Isopar G Solvent	Photocopier diluent	m.w. 148	0.8	+		ne
Isopar K Solvent	Isoparaffinic hydrocarbons	m.w. 156	0.5	+		ne
Isopar L Solvent	Isoparaffinic hydrocarbons	m.w. 163	0.5	+		
Isopar M Solvent	Isoparaffinic hydrocarbons	m.w. 191	0.7	+		
Isopentane	2-Methylbutane	C5H12	8.2			ne
Isophorone		C9H14O	?		9.07	C5
Isoprene	2-Methyl-1,3-butadiene	C5H8	0.63	+	8.85	ne
Isopropanol	Isopropyl alcohol, 2-propanol	C3H8O	6.0	+	10.12	400

Compound Name	Synonym/Abbreviation	Formula	Response Factor	¹ Confirmed Value	IP (eV)	TWA
Isopropyl acetate		C5H10O2	2.6		9.99	250
Isopropyl ether	Diisopropyl ether	C6H14O	0.8		9.20	250
Jet fuel JP-4	Jet B, Turbo B, Wide cut type aviation fuel	m.w. 115	1.0	+		ne
Jet fuel JP-5	Jet 5, Kerosene type aviation fuel	m.w. 167	0.6	+		15
Jet fuel JP-8	Jet A-1, Kerosene type aviation fuel	m.w. 165	0.6	+		15
Limonene, D-	®-(+)-Limonene	C10H16	0.33	+	~8.2	ne
Kerosene (C10-C16 petro. Distillate – see Jet Fuels)						
MDI (see 4,4'-Methylenebis (phenylisocyanate))						
Mesitylene	1,3,5-Trimethylbenzene	C9H12	0.35	+	8.41	ne
Methane	Natural gas	CH4	NR	+	12.51	ne
Methanol	Methyl alcohol, carbinol	CH4O	NR	+	10.85	200
Methoxyethanol, 2-	Methyl cellosolve, Ethylene glycol 48onomethyl ether	C3H8O2	2.4	+	10.1	5
Methoxyethoxyethanol, 2-	2-(2-Methoxyethoxy)ethanol Diethylene glycol monomethyl ether	C7H16O3	1.2	+	<10	ne
Methyl acetate		C3H6O2	6.6	+	10.27	200
Methyl acrylate	Methyl 2-propenoate, acrylic acid methyl ester	C4H6O2	3.7	+	-9.9	2
Methylamine	Aminomethane	CH5N	1.2		8.97	
Methyl bromide	Bromomethane	CH3Br	1.7	+	10.54	1
Methyl t-butyl ether	MTBE, tert-Butyl methyl ether	C5H12O	0.9	+	9.24	40
Methyl cellosolve (see 2-Methoxyethanol)						
Methyl chloride	Chloromethane	CH3Cl	NR	+	11.22	50
Methylcyclohexane		C7H14	0.97	+	9.64	400
Methylene bis (phenyl-isocyanate)	MDI, Mondur M	C15H10N2O2	Very slow ppb level response	+		0.005
4,4'-Methylene chloride	Dichloromethane	CH2Cl2	NR	+	11.32	25
Methyl ether	Dimethyl ether	C2H6O	3.1	+	10.03	ne
Methyl ethyl ketone	MEK, 2-Butanone	C4H8O2	0.9	+	9.51	200
Methylhydrazine	Monomethylhydrazine, Hydrazomethane	C2H6N2	1.2	+	7.7	0.01
Methyl isobutyl ketone	MIBK, 4-Methyl-2-pentanone	C6H12O	0.8	+	9.30	50
Methyl Isocyanate	CH3NCO	C2H3NO	4.6	+	10.67	0.02
Methyl isothiocyanate	CH3NCS	C2H3NS	0.45	+	9.25	ne
Methyl mercaptan	Methanethiol	CH4S	0.54		9.44	0.5
Methyl methacrylate		C5H8O2	1.5	+	9.7	100
Methyl nonafluorobutyl ether	HFE-7100DL	C5H3F9O	NR	+		ne
Methyl-1,5-pentane-diamine, 2- (coats lamp)	Dytek-A amine, 2-Methyl pentamethylenediamine	C6H16N2	~0.6	+	<9.0	ne
Methyl propyl ketone	MPK, 2-Pentanone	C5H12O	0.93	+	9.38	200
Methyl-2-pyrrolidinone, N-	NMP, N-Methylpyrrolidone, 1-Methyl-2-pyrrolidinone, 1-Methyl-2-pyrrolidone	C5H9NO	0.8	+	9.17	ne
Methyl salicylate	Methyl 2-hydroxybenzoate	C8H8O3	1		~9	ne
Methylstyrene, a-	2-Propenylbenzene	C9H10	0.5		8.18	50
Methyl sulfide	DMS, Dimethyl sulfide	C2H6S	0.44	+	8.69	ne
Mineral spirits (Stoddard Solvent, see also Viscor 120B)		m.w. 144	0.7	+		100
Mineral spirits Viscor 120B Calibration Fluid, b.p. 156-207°C		m.w. 142	0.7	+		100
Mustard	HD, Bis (2-chloroethyl) sulfide	C4H8Cl2S	0.6			0.0005

<i>Compound Name</i>	<i>Synonym/Abbreviation</i>	<i>Formula</i>	<i>Response Factor</i>	<i>¹Confirmed Value</i>	<i>IP (eV)</i>	<i>TWA</i>
Naphthalene	Mothballs	C10H8	0.42	+	8.13	10
Nitric oxide		NO	5.2	+	9.26	25
Nitrobenzene		C6H5NO2	1.9	+	9.81	1
Nitroethane		C2H5NO2	NR		10.88	100
Nitrogen dioxide		NO2	16.0	+	9.75	3
Nitromethane		CH3NO2	NR		11.02	20
Nitropropane, 2-		C3H7NO2	NR		10.71	10
Nonane		C9H20	1.4		9.72	200
Octane, n-		C8H18	1.8	+	9.82	300
Pentane		C5H12	8.4	+	10.35	600
Peracetic acid	Peroxyacetic acid, Acetyl Hydroperoxide	C2H4O3	NR	+		ne
Peracetic/Acetic acid mix	Peroxyacetic acid, Acetyl Hydroperoxide	C2H4O3/C2H4O2	50	+		ne
Perchloroethene	PCE, Perchloroethylene, Tetrachloroethylene	C2Cl4	0.57	+	9.32	25
PGME	Propylene glycol methyl ether, 107-98-2 1-Methoxy-2-propanol	C6H12O3	1.5	+		100
PGMEA	Propylene glycol methyl ether 108-65-6 acetate, 1-Methoxy-2-acetoxypropane, 1-Methoxy-2-propanol acetate	C6H12O3	1.0	+		ne
Phenol	Hydroxybenzene	C6H6O	1.0	+	8.51	5
Phosgene	Dichlorocarbonyl	CCl2O	NR		11.2	0.1
Phosphine in N2		PH3	3.9	+	9.87	0.3
Photocopier Toner	Isoparaffin mix		0.5	+		
Picoline, 3-	3-Methylpyridine	C6H7N	0.9		9.04	
Pinene, a-		C10H16	0.31	+	8.07	ne
Pinene, b		C10H16	0.37	+	~8	100
Piperylene, isomer mix	1,3-Pentadiene	C5H8	0.69	+	8.6	100
Propane		C3H8	NR	+	10.95	2500
Propanol, n-	Propyl alcohol	C3H8O	5		10.22	200
Propene	Propylene	C3H6	1.4	+	9.73	ne
Propionaldehyde	Propanal	C3H6O	1.9		9.95	ne
Propyl acetate, n-		C5H10O2	3.5		10.04	200
Propylene carbonate		C4H6O3	62	+	10.5	ne
Propylene glycol	1,2-Propanediol	C3H8O2	5.5	+	<10.2	ne
Propylene oxide	Methyloxirane	C3H6O	6.6	+	10.22	20
Propyleneimine	2-Methylaziridine	C3H7N	1.3	+	9.0	2
Propyl 49ercaptan, 2-	2-Propanethiol, Isopropyl mercaptan	C3H7N	0.66	+	9.2	ne
Pyridine		C5H5N	0.7	+	9.25	5
Pyrrolidine (coats lamp)	Azacyclohexane	C4H9N	1.3	+	~8.0	ne
RR7300 (PGME?PGMEA)	70:30 PGME:PGMEA (1-Methoxy-2-propanol:1-Methoxy-2-acetoxypropane)	C4H10O2 / C6H12O3	1.4	+		ne
Sarin	GB, Isopropyl methylphosphonofluoridate	C4H10FO2P	~3			
Stoddard Solvent (see Mineral Spirits)						
Styrene		C8H8	0.40	+	8.43	20
Sulfur dioxide		SO2	NR	+	12.32	
Sulfur hexafluoride		SF6	NR		15.3	1000
Sulfuryl fluoride	Vikane	SO2F2	NR		13.0	6
Tabun	Ethyl N, N-dimethylphosphoramidocyanidate	C5H11N2O2P	0.8			15ppt
Tetrachloroethane, 1,1,1,2-		C2H2Cl4	NR		~11.1	ne
Tetrachloroethane, 1,1,2,2-		C2H2Cl4	NR	+	~11.1	1

Compound Name	Synonym/Abbreviation	Formula	Response Factor	¹ Confirmed Value	IP (eV)	TWA
Tetraethyllead	TEL	C ₈ H ₂₀ Pb	0.3		~11.1	0.008
Tetraethyl orthosilicate	Ethyl silicate, TEOS	C ₈ H ₂₀ O ₄ Si	0.7	+	~9.8	10
Tetrafluoroethane, 1,1,1,2-	HFC-134A	C ₂ H ₂ F ₄	NR			ne
Tetrafluoroethene	TFE, Tetrafluoroethylene, Perfluoroethylene	C ₂ F ₄	~15		10.12	ne
Tetrafluoromethane	CFC-14, Carbon tetrafluoride	CF ₄	NR	+	>15.3	ne
Tetrahydrofuran	THF	C ₄ H ₈ O	1.7	+	9.41	200
Tetramethyl orthosilicate	Methyl silicate, TMOS	C ₄ H ₁₂ O ₄ Si	1.9	+	~10	1
Therminol VP-1	Dowtherm,3:1 Diphenyl oxide: Biphenyl	C ₁₂ H ₁₀ O C ₁₂ H ₁₀	0.7	+		ne
Toluene	Methylbenzene	C ₇ H ₈	0.50	+	8.82	50
Tolylene-2,4-diisocyanate	TDI, 4-Methyl-1,3-phenylene-2,4- diisocyanate	C ₉ H ₆ N ₂ O ₂	1.4	+		0.002
Trichlorobenzene, 1,2,4-	1,2,4-TCB	C ₆ H ₃ Cl ₃	0.46	+	9.04	C5
Trichloroethane, 1,1,1-	1,1,1-TCA, Methyl chloroform	C ₂ H ₃ Cl ₃	NR	+	11	350
Trichloroethane, 1,1,2-	1,1,2-TCA	C ₂ H ₃ Cl ₃	NR	+	11.0	10
Trichloroethene	TCE, Trichloroethylene	C ₂ HCl ₃	0.54	+	9.47	50
Trichlorotrifluoroethane, 1,1,2- CFC-113		C ₂ Cl ₃ F ₃	NR		11.99	1000
Triethylamine	TEA	C ₆ H ₁₅ N	0.9	+	7.3	1
Triethyl borate	TEB; Boric acid triethyl ester, Boron ethoxide	C ₆ H ₁₅ O ₃ B	2.2	+	~10	
Triethyl phosphate	Ethyl phosphate	C ₆ H ₁₅ O ₄ P	3.1	+	9.79	ne
Trifluoroethane, 1,1,2- Trimethylamine		C ₂ H ₃ F ₃	NR		12.9	ne
Trimethylbenzene, 1,3,5- (see Mesitylene)		C ₃ H ₉ N	0.9		7.82	5
Trimethyl borate	TMB; Boric acid trimethyl ester, Boron methoxide	C ₃ H ₉ O ₃ B	5.1	+	10.10	ne
Trimethyl phosphate	Ethyl phosphate	C ₃ H ₉ O ₄ P	8.0	+	9.99	ne
Turpentine	Pinenes (85%) + other diisoprenes	C ₁₀ H ₁₆	0.3	+	~8	100
Undecane		C ₁₁ H ₂₄	2		9.56	ne
Varsol (see Mineral Spirits)						
Vinyl acetate		C ₄ H ₆ O ₂	1.2	+	9.19	10
Vinyl bromide	Bromoethylene	C ₂ H ₃ Br	0.4		9.80	5
Vinyl chloride in N ₂	Chloroethylene, VCM	C ₂ H ₃ Cl	2.0	+	9.99	5
Vinylidene chloride – (see 1,1-Dichloroethene)						
Vinyl-2-pyrrolidinone, 1-	NVP, N-vinylpyrrolidone, 1-ethenyl-2-pyrrolidinone	C ₆ H ₉ NO	0.8	+		ne
Viscor 120B – (see Mineral Spirits – Viscor 120B Calibration Fluid)						
Xylene, m-		C ₈ H ₁₀	0.4	+	8.56	
Xylene, o-		C ₈ H ₁₀	0.6	+	8.56	
Xylene, p-		C ₈ H ₁₀	0.5	+	8.44	

NR = not recommended (does not register)

? = measurable but no data exists

Confirmed Value = "+" means actual gas has been used to verify RF, "blank" means it is an empirical estimate

IP = is the gases ionization potential (only gases < 10.6eV will respond to sensor)

TWA/Time Weighted Average = generally accepted limit for safe 8 hour exposure (in ppm)

ne = None established

9.3 Spare Parts, Sensor Accessories, Calibration Equipment

Part Number	Spare Parts
S927-xx0000-xxxx ²	PI-700 Intelligent Transmitter Module (ITM for VOC Gas Sensors)
S967-xx0xxx-xxxx ²	PI-700 ITM with Lower Housing, Cell, and Splash Guard
602-003295-FLT	Model PI-700 Splash Guard Adapter with Integral Filter
377-PB0000-0XX	Replacement Plug-in VOC gas sensor (≤ 20 ppm where XX=range)
377-PM0000-XXX	Replacement Plug-in VOC gas sensor (> 20 ppm where XXX=range)
500-003087-100	Transient Protection PCA
Sensor Accessories	
897-850800-010	NEMA 7 Aluminum Enclosure less cover – 3 port
897-850400-010	NEMA 7 Aluminum Enclosure Cover (Blank)
897-850801-316	NEMA 7 316SS Enclosure less cover – 3 port
897-850401-316	NEMA 7 316SS Enclosure Cover (Blank)
602-003295-000	Splashguard Adapter without Integral Filter
613-120000-700	Sensor Splashguard with Cal Port
613-2R0000-000	Remote Calibration Adapter
943-002273-000	Harsh Environment Sensor guard
327-000000-000	Programming Magnet
960-202200-000	Condensation prevention packet (for J-Box replace annually)
960-700PID-000	Moisture control Packet for plug-in sensor
017-557718-000	O-ring (used to secure Moisture Control Packet)
PID Cell Spare Parts	
975-520040-000	PID Lamp Cleaning Kit
975-600020-000	PID Replacement 10.6eV Lamp
975-600037-591	PID Replacement Filter Media
975-600038-083	PID Replacement Filter Media 1
975-600042-078	PID Replacement Spacer
975-600042-930	PID Replacement Filter Cap
Calibration Accessories	
943-000000-000	Calibration Wind Guard
943-000006-132	Threaded Calibration Adapter
943-020000-000	Span Gas Kit: Includes calibration adapter, span gas humidifier, 200cc/min fixed flow regulator, and carrying case. (Not including gas).
942-001123-000	Zero Air 103Liters
See Detcon	For Isobutylene Span Gasses (Range Specific)
943-090005-502	500 cc/min Fixed Flow Regulator for span gas bottle
985-241100-321	In-Line Humidifying Tube 24”
Recommend Spare Parts for 2 Years	
S927-xx0000-xxxx ²	PI-700 Intelligent Transmitter Module (ITM for VOC Gas Sensors)
600-003295-FLT	Model PI-700 Splash Guard Adapter with Integral Filter
377-PB0000-0XX	Replacement Plug-in VOC gas sensor (≤ 20 ppm where XX=range)
377-PM0000-XXX	Replacement Plug-in VOC gas sensor (> 20 ppm where XXX=range)
500-003087-100	Transient Protection PCA
960-202200-000	Condensation prevention packet (for J-Box. Replace annually)
960-700PID-000	Moisture Control Packet for sensor
017-557718-000	O-ring (used to secure Moisture Control Packet)

² Contact Teledyne Detcon Customer Service for a complete part number

10.Revision Log

Revision	Date	Changes made	Approval
0.0	08/01/06	Initial Manual release.	BM
0.1	04/01/07	Engineering drawings changed to rev 1.	BM
0.2	11/26/07	Engineering drawings changed to rev 2.	BM
1.0	02/29/08	Yellow wire removed from ITM assembly, changed from DM 700 splashguard adapter to PI-700 Splashguard adapter.	BM
1.1	07/14/08	PID Sensor maintenance procedure modified.	BM
1.2	10/01/09	Added in-line humidifying tube to calibration procedures and Spare parts, Added PI-700 Splashguard adapter to Spare parts. Updated engineering drawings to rev 4.	BM
1.3	11/16/09	Addition of Splashguard Adapter with Integral Filter to Maintenance and Accessories.	BM
1.4	12/17/09	Changed Warranty period from 6 months to 12 months on PID Sensor cell	BM
1.5	05/12/10	Updated engineering drawings to rev 5. Splash Guard adapter with Integral Filter now Standard, (before was option) Changed Spare parts list	BM
1.6	12/13/10	Correction to Note 2 page 15. Regarding flow rate	BM
1.7	04/25/11	Added standard EN60079-11 to Section 2.1 and removed Teflon note in Section 2.5.	LU
1.8	7/11/11	Added Inrush current information to Specifications section. Added dimensional drawings for Aluminum conduit	LU
1.9	04/16/12	Changed cable recommendation, updated the Modbus Register Map, company address.	LU
2.0	01/07/13	Updated ATEX approvals label, updated EN standards that sensor assembly meets.	BM
2.1	04/10/13	Added max/min AutoSpan chart	LU
2.2	11/19/13	Updated approvals label	BM
2.3	12/25/13	Update Calibration to include Wind Guard	BM
2.4	02/12/14	Clarifications to span cal procedure with target gas	LU
2.5	04/15/14	Update Specification to reflect slower response times	BM
3.0	06/16/16	Update cert specs, update technical information.	MM
3.1	10/26/17	Updated Sensor Drawing Dimensions and ATEX Approval Label	LU
3.2	06/05/18	Updated Conduit Seal in Section 2.5	MM
3.3	09/06/18	Updated Temperature Specification and Approval Label	MM
3.4	08/13/19	Updated Regulatory Markings and Temperature Specifications	MM
3.5	11/11/19	Updated Company Information	MM
3.6	03/02/20	Updated ATEX Standards Information	MM
3.7	03/17/21	Updated approvals label, updated company address	KM
3.8	10/19/22	Added certification information for IECEX	KM
3.9	12/22/22	Updated Certifications	KM
4.0	07/14/23	Updated for new PI Cell, Changes in Sections 5.1 and 9.3	KM

This page left intentionally blank

Shipping Address: 14880 Skinner Road, Cypress, Texas 77429
Phone: 713.559.9200

<http://www.teledynegasandflamedetection.com> • detcon-sales@teledyne.com